



# All-Metal Variable Area Flowmeter

for liquids and gases



measuring  
•  
monitoring  
•  
analysing

KDS



- Measuring range:  
0.1 - 1 l/h ... 20 - 200 l/h water  
3 - 30 NI/h ... 600 - 6000 NI/h air
- Accuracy:  
±3 % of full scale
- $p_{\max}$ : 420 bar;  $t_{\max}$ : 130 °C
- Connection:  
1/4" NPT female thread (option  
valve)
- Material: stainless steel
- Contacts, analogue output  
(optional)

51

KOBOLD companies worldwide:

AUSTRALIA, AUSTRIA, BELGIUM, BULGARIA, CANADA, CHINA, CZECHIA, FRANCE, GERMANY, GREAT BRITAIN, HUNGARY, INDIA, INDONESIA, ITALY, MALAYSIA, MEXICO, NETHERLANDS, PERU, POLAND, REPUBLIC OF KOREA, RUSSIA, SPAIN, SWITZERLAND, THAILAND, TUNISIA, TURKEY, USA, VIETNAM

KOBOLD Messring GmbH  
Nordring 22-24  
D-65719 Hofheim/Ts.  
Head Office:  
+49(0)6192 299-0  
+49(0)6192 23398  
info.de@kobold.com  
www.kobold.com



**Function**

The fluid flows from bottom to top through the meter tube of the flow meter. The float is lifted until an annular gap between the measuring cone and the float is produced which corresponds to the flow. The forces acting on the float are in equilibrium.

The height of the float resulting from the flow rate is transmitted by the permanent magnet in the float through the magnetic tracking system in a rotation to the pointer axis of the analog indicator unit.

The variable-area flowmeter consists of a stainless steel device with an integrated conical stainless steel measuring tube and a vertically movable float. The valve for setting the flow rate is built-in (only KDS-K/C).

**Application**

The KDS meter is suitable for flow measurement of liquid or gaseous products in pipes.

It shows the current flow rate in volume or mass per unit in time.

**Areas of Application**

- Flow measurement of liquids and gases
- Dosing
- Can be used in the chemical industry or in medical or laboratory engineering
- Robust mechanical system with a low rate of wear

The devices are available with additional electrical equipment for process monitoring and control.

- Design for horizontal and vertical connections available
- A variety of sealing materials
- Wall mounting possibility (KDS-C)
- Flow Controller (option)
- High pressure application (option)

**Technical Details**

**Materials**

Measuring cone, float, armature: stainless steel  
other materials on request

Sealing: PTFE (special on request)

Process connection: 1/4" NPT (F), adapter for other connections available  
special connections on request

Nominal pressure: PN 40 (KDS-K, C)  
PN 63 (KDS-S)  
optional up to 420 bar (KDS-S)

Accuracy liquid/gas: ±3 % q<sub>G</sub> 50 acc. VDE/VDI 3513

Process temperature: -40 °C ... +130 °C (without switch/electronic)  
limit switch: NJ 1, 5-6, 5N -25 °C ... +100 °C  
NJ 2-11 SN -40 ... +100 °C  
-40 °C ... +100 °C (c/w electronic KDS- ... E)

Ambient temperature: -25 °C ... +70 °C

Weight: 0.65 kg

Protection: IP 65 (EN60529)

**Certificate and Approval**

Explosion protection: BVS 03 ATEX H/B 113

**Pressure drop: [H<sub>2</sub>O/mbar]**

Measuring range	KDS-S...	KDS-K/C...
A	6	6
B	7.5	7
C	7.5	7
D	8	10
E	9	12
F	10	17
G	11	25
H	12	45
I	15	95
J	20	-
K	28	-

Reference condition:  
according to IEC 770, water at 20 °C complete opened valve



**Display:** %-scale  
measuring range scale

**Electrical outputs:**

Limit contacts: 1 up to max. 2 inductive limit contacts, NAMUR (Pepperl & Fuchs NJ 1.5 ... 6.5 N); 8.2 V ( $R_i \sim 1 \text{ K}\Omega$ ) (NJ 2 ... 11-SN); 5 ... 25 V<sub>DC</sub> (safety wiring)

Analogue output (KDS-...E): 4 ... 20 mA, 2-wire, passive; 14-30 V; burden max. 500  $\Omega$  version Ex (intrinsically safe) electrical connection via M12 plug

Ambient temperature: -25 °C ... +70 °C

**Certification and Approvals**

Explosion protection: NJ1,5-6,5N PTB 00 ATEX 2048 X II 2G Ex ia IIC T6-T4  
NJ 2-11SN PTB 00 ATEX 2049 X II 2G Ex ia IIC T6-T4  
ZELM 03 ATEX 0128 X II 1D Ex iaD 20 T ... °C  
KDS-(E) II 2G Ex ib IIC T4 Gb, II 2D Ex ib IIIC T 135°C Db

CE-Marking: Explosion Protection Directive 94/9/EC, PED 97/23/EC

Electromagnetic compatibility for add-on electrical sensors: EMC-Directive 2004/108/EC EN 61326-1:2006

SIL: SIL conformity acc. IEC-61508-2:2000 and IEC-61508-2:2010, declaration of conformity as separate document available

**Connection vertical KDS-S... (Example: KDS-SA P 30 A 00)**

	Measuring range		Order-code	Material	Connection	Scale	Contacts	Special option
	Water (1000 kg/m <sup>3</sup> )  l/h	Air <b>1.013 bar abs., 20 °C</b>  NI/h						
	0,1 - 1,0	3 - 30	KDS-SA...	P = st. steel/ PTFE fitting X = special	30 = 1/4" NPT female	A = % scale B = standard- scale H <sub>2</sub> O C = standard- scale air D = % scale fluid E = MR-scale fluid F = double scale acc. to specification X = special scale	0 = without 1 = 1x Inductive contact 2 = 2x Inductive contacts 3 = 1x Inductive contact acc. to safety standard E = transmitter 4-20 mA without HART®, EEX ib	0 = without X = special acc. to specifi- cation
	0,25 - 2,5	5 - 50	KDS-SB...					
	for gases only	6 - 60	KDS-SL...					
	for gases only	7 - 70	KDS-SM...					
	for gases only	11 - 110	KDS-SN...					
	0,6 - 6,0	18 - 180	KDS-SC...					
	1,0 - 10	30 - 300	KDS-SD...					
	1.6 - 16	48 - 480	KDS-SE...					
	2.5 - 25	75 - 750	KDS-SF...					
	4.0 - 40	120 - 1200	KDS-SG...					
	6.0 - 60	180 - 1800	KDS-SH...					
	10 - 100	300 - 3000	KDS-SI...					
	16 - 160	480 - 4800	KDS-SJ...					
20 - 200	600 - 6000	KDS-SK...						



All-Metal Variable Area Flowmeter Model KDS

Connection horizontal KDS-K... (Example: KDS-KA P 30 A 0 0)

	Measuring range		Order code	Material	Connection	Scale	Contacts	Special option
	Water (1000 kg/m <sup>3</sup> ) l/h	Air 1.013 bar abs., 20 °C NI/h						
	0.1 - 1.0	3 - 30	KDS-KA...	P = st. steel/ PTFE fitting X = special	30 = ¼" NPT female  U0* = ¼" NPT female valve at bottom  00 = ¼" NPT female valve at top	A = % scale B = standard- scale H <sub>2</sub> O C = standard- scale air D = % scale fluid E = MR-scale fluid F = double scale acc. to specifi- cation X = special scale	0 = without 1 = 1 x Inductive contact 2 = 2 x Inductive contacts 3 = 1 x Inductive contact acc. to safety standard E = transmitter 4-20 mA without HART®, EEX ib	0 = without X = special acc. to specifi- cation
	0.25 - 2.5	5 - 50	KDS-KB...					
	for gases only	6 - 60	KDS-KL...					
	for gases only	7 - 70	KDS-KM...					
	for gases only	11 - 110	KDS-KN...					
	0.6 - 6.0	18 - 180	KDS-KC...					
	1.0 - 10	30 - 300	KDS-KD...					
	1.6 - 16	48 - 480	KDS-KE...					
	2.5 - 25	75 - 750	KDS-KF...					
	4,0 - 40	120 - 1200	KDS-KG...					
	6.0 - 60	180 - 1800	KDS-KH...					
	10 - 100	300 - 3000	KDS-KI...					

\* not with el. output "E"



Connection horizontal for wall mounting KDS-C... (Example: KDS-CA P 30 A 0 0)

	Measuring range		Order-code	Material	Connection	Scale	Contacts	Special option
	Water (1000 kg/m <sup>3</sup> )  l/h	Air 1.013 bar abs., 20°C  NI/h						
	0.1 - 1.0	3 - 30	KDS-CA...	P = st. steel/ PTFE fitting X = special	30 = ¼" NPT female U0 = ¼" NPT female valve at bottom O0 = ¼" NPT female valve at top	A = % scale B = standard- scale H <sub>2</sub> O C = standard- scale air D = % scale fluid E = MR-Scale fluid F = double scale acc. to specifi- cation X = special scale	0 = without 1 = 1 x Inductive contact 2 = 2 x Inductive contacts 3 = 1 x Inductive contact acc. to safety standard E = transmitter 4-20 mA without HART®, EEX ib	0 = without X = special acc. to specifi- cation
	0.25 - 2.5	5 - 50	KDS-CB...					
	for gases only	6 - 60	KDS-CL...					
	for gases only	7 - 70	KDS-CM...					
	for gases only	11 - 110	KDS-CN...					
	0.6 - 6.0	18 - 180	KDS-CC...					
	1.0 - 10	30 - 300	KDS-CD...					
	1.6 - 16	48 - 480	KDS-CE...					
	2.5 - 25	75 - 750	KDS-CF...					
	4.0 - 40	120 - 1200	KDS-CG...					
	6.0 - 60	180 - 1800	KDS-CH...					
10 - 100	300 - 3000	KDS-CI...						



All-Metal Variable Area Flowmeter Model KDS

Dimensions (mm)

KDS-K, C

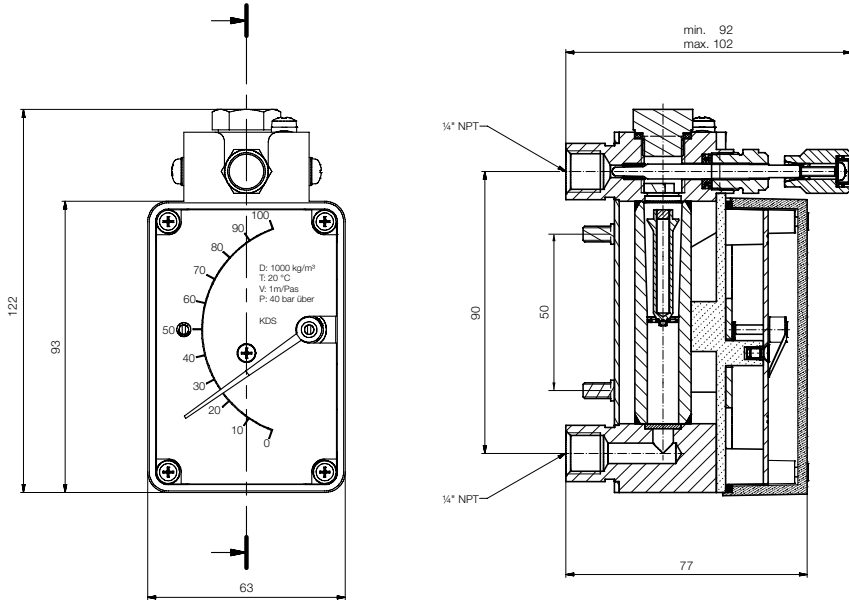

KDS-S

