

Model 261GS for gauge pressure Model 261AS for absolute pressure

Series 2600T Pressure Transmitters

Engineered solutions for all applications



Standard overload capability

Base accuracy

— $\pm 0.15\%$ ($\pm 0.1\%$ optional)

Span limits

— 0.3 ... 60,000 kPa; 1.2 in H₂O up to 8,700 psi
— 0.3 ... 3,000 kPa abs.; 2.25 mmHg up to 435 psia

Proven sensor technology together with state-of-the-art digital technology

— Large turndown ratio of up to 20:1

Stainless steel housing

— Optimized for use in extreme conditions
— Extremely sturdy design

Flexible configuration options

— Local configuration via setup button for upper and lower range limit values
— Local configuration via keys on LCD display
— Via handheld terminal or PC user interface

Full compliance with Pressure Equipment Directive (PED) category III

Contents

1	Functional specifications	3
2	Operating limits	4
2.1	Pressure limits	4
2.2	Test pressure	4
3	Environmental limits	5
4	Potentially explosive atmospheres	6
5	Electrical data and options	7
5.1	HART digital communication and 4 ... 20 mA output current	7
6	Measuring accuracy	8
7	Operating influences	8
8	Technical specification	9
9	Configuration	9
9.1	Transmitter with HART communication and 4 ... 20 mA output current	9
10	Mounting dimensions (not design data)	10
11	Electrical connections	15
11.1	Standard terminal strip	15
11.2	Optional plug connectors	15
12	Ordering information	16
12.1	Ordering information for model 261GS/261AS	16
12.2	Additional ordering information for model 261GS/261AS	17
13	Standard scope of delivery (changes may be made by using additional ordering code)	17

1 Functional specifications

Measuring range and span limits

Sensor code	Upper range limit (URL)	Lower range limit (LRL) for 261GS	Minimum span	
			261GS Gauge pressure	261AS Absolute pressure
C	6 kPa 60 mbar 24 in H ₂ O	-6 kPa -60 mbar -24 in H ₂ O	0.3 kPa 3 mbar 1.2 in H ₂ O	0.3 kPa 3 mbar 2.25 mm Hg
F	40 kPa 400 mbar 160 in H ₂ O	-40 kPa -400 mbar -160 in H ₂ O	2 kPa 20 mbar 8 in H ₂ O	2 kPa 20 mbar 15 mm Hg
L	250 kPa 2500 mbar 1000 in H ₂ O	Absolute 0	12.5 kPa 125 mbar 50 in H ₂ O	12.5 kPa 125 mbar 93.8 mm Hg
D	1000 kPa 10 bar 145 psi	Absolute 0	50 kPa 500 mbar 7.25 psi	50 kPa 500 mbar 375 mm Hg
U	3000 kPa 30 bar 435 psi	Absolute 0	150 kPa 1.5 bar 21.7 psi	150 kPa 1.5 bar 21.7 psi
R	10000 kPa 100 bar 1450 psi	Absolute 0	500 kPa 5 bar 72.5 psi	500 kPa 5 bar 72.5 psi
V	60000 kPa 600 bar 8700 psi	Absolute 0	3000 kPa 30 bar 435 psi	



Important

The lower range limit (LRL) for 261AS is absolute 0 for all measuring ranges.

Span limits

Maximum span = URL = Upper range limit

To optimize performance characteristics, it is recommended that you select the transmitter sensor with the lowest turndown ratio.

TURNDOWN = Upper range limit/set span

Zero position suppression and elevation

The zero position and span can be set to any value within the range limits listed in the table if:

- Set span \geq minimum span

Damping

Adjustable time constant: 0 ... 60 s

This is in addition to the sensor response time, and can be set via the optional LCD indicator, handheld terminal, or PC user interface.

Warm-up period

Operation within specifications: \leq 10 s with minimum damping

Insulation resistance

$>$ 100 M Ω at 500 V DC (between terminals and ground)

2 Operating limits

Temperature limits in °C (°F)

	Ambient temperature range
Operating temperature range	-40 ... 85 °C (-40 ... 185 °F)
White oil filling	-6 ... 85 °C (21 ... 185 °F)
LCD display	-20 ... 70 °C (-4 ... 158 °F)
Viton gasket:	-20 ... 85 °C (-4 ... 185 °F)
Perfluoroelastomer gasket	-25 or -15 ... 80 °C (-13 or 5 ... 176 °F) See "Pressure limits" section



Important

For applications in potentially explosive atmospheres, the temperature range specified on the relevant certificate/approval must be observed.

	Process temperature range
Process temperature range	-50 ... 120 °C (-58 ... 248 °F)
White oil filling	-6 ... 85 °C (21 ... 185 °F)
Viton gasket	-20 ... 120 °C (-4 ... 248 °F)
Perfluoroelastomer gasket	-25 or -15 ... 80 °C (-13 or 5 ... 176 °F) See "Pressure limits" section

Storage

	Storage temperature range
Storage temperature	-50 ... 85 °C (-58 ... 185 °F)
LCD display	-40 ... 85 °C (-40 ... 185 °F)
White oil filling	-6 ... 85 °C (21 ... 185 °F)

	Humidity during storage
Relative humidity	Up to 75 %

2.1 Pressure limits

Overpressure limits

(without damage to the transmitter)

Sensor code	Overpressure limits; Absolute 0 to:
C, F	1 MPa, 10 bar, 145 psi
L	0.5 MPa, 5 bar, 72.5 psi
D	2 MPa, 20 bar, 290 psi
U	6 MPa, 60 bar, 870 psi
R	20 MPa, 200 bar, 2900 psi
V	90 MPa, 900 bar, 13050 psi
Perfluoroelastomer gasket T ≥ -15 °C (5 °F)	0.6 MPa abs, 6 bar abs, 87 psia
Perfluoroelastomer gasket T ≥ -25 °C (-13 °F)	0.18 MPa abs, 1.8 bar abs, 26 psia

2.2 Test pressure



Important

When testing pressure on the pressure transmitter, please ensure that you observe the overpressure limits.

3 Environmental limits

Electromagnetic compatibility (EMC)

The device conforms to the requirements and tests for EMC Directive 89/336/EC, as well as EN 61000-6-3 concerning emitted interference and EN 61000-6-2 concerning interference immunity.

It meets NAMUR recommendations.

Low Voltage Directive

Complies with 73/23/EC.

Pressure Equipment Directive (PED)

Complies with 97/23/EC Category III, module H.

Humidity

Relative humidity: Up to 100 %

Condensation, icing: Permissible

Vibration resistance

Acceleration up to 2 g at frequencies up to 1,000 Hz (according to IEC 60068-2-6).

Shock resistance (according to IEC 60068-2-27)

Acceleration: 50 g

Duration: 11 ms

Protection type (humid and dusty atmospheres)

The transmitter is dust and sand-tight, and is protected against immersion effects as defined by the following standards:

- IEC EN60529 (1989) with IP 67 (with IP 68, IP 69K on request)
- NEMA 4X
- JIS C0920

Protection type with plug connector: IP 65

4 Potentially explosive atmospheres

Transmitter with "Intrinsically safe EEx ia/ib" type of explosion protection in accordance with Directive 94/9/EC (ATEX)

Transmitter with 4 ... 20 mA output signal and HART communication:

Identification (DIN EN 50014):

II 1/2 G EEx ia IIC T4 ... T6

II 2 G EEx ib IIC T4 ... T6

Permissible ambient temperature range depending on temperature class:

Ambient temperature	Temperature class
-40 ... 85 °C (-40 ... 185 °F)	T1 ... T4
-40 ... 71 °C (-40 ... 159 °F)	T5
-40 ... 56 °C (-40 ... 132 °F)	T6

or identification (DIN EN 50014):

II 1/2 D IP 65 T95 °C Ex ia D

II 2 D IP 65 T95 °C Ex ib D

Permissible ambient temperature range:

-40 ... 85 °C (-40 ... 185 °F)

Supply and signal circuit with "Intrinsically safe EEx ia/ib IIB/IIC" type of explosion protection, with the following maximum values:

$U_i = 30 \text{ V}$

$I_i = 130 \text{ mA}$

$P_i = 0.8 \text{ W}$

Effective internal capacitance: $C_i = 10 \text{ nF}$

Effective internal inductance: $L_i = 0.5 \text{ mH}$

Factory Mutual (FM)

Transmitter with 4 ... 20 mA output signal and HART communication:

Intrinsically safe: Class I, II and III; Division 1;
Groups A, B, C, D, E, F, G
Class I; Zone 0; AEx ia
Group IIC T6; T4

Non-incendive: Class I, II and III; Division 2;
Groups A, B, C, D, F, G

Protection type: NEMA type 4X (indoor and
outdoor installation)

Canadian Standards Association (CSA)

Transmitter with 4 ... 20 mA output signal and HART communication

Intrinsically safe: Class I, II and III; Division 1;
Groups A, B, C, D, E, F, G
Class I; Zone 0; Group IIC T6;
T4

Non-incendive: Class I, II, III; Division 2;
Groups A, B, C, D, F, G

Protection type: NEMA type 4X (indoor and
outdoor installation)

NEPSI (China)

Transmitter with 4 ... 20 mA output signal and HART communication:

Intrinsically safe: (Gas, order code X3)

Identification: Ex ia II CT1~CT6

Permissible ambient temperature range depending on temperature class:

	$U_i \text{ max.} = 30 \text{ V}; I_i \text{ max} = 130 \text{ mA}; P_i = 0.8 \text{ W};$ $C_i = 10 \text{ nF}; L_i = 0.5 \mu\text{H}$		
Ex ia II CT1 ... T6	T6	T5	T1 ... T4
	-40 ... 56 °C	-40 ... 71 °C	-40 ... 85 °C

Intrinsically safe: (Gas and dust,
order code X4)

Identification: Ex ia II CT1~T6;
DIP A20 T_A 95 °C

Permissible ambient temperature range depending on temperature class:

	$U_i \text{ max.} = 30 \text{ V}; I_i \text{ max} = 130 \text{ mA}; P_i = 0.8 \text{ W};$ $C_i = 10 \text{ nF}; L_i = 0.5 \mu\text{H}$		
Ex ia II CT1 ... T6	T6	T5	T1 ... T4
	-40 ... 56 °C	-40 ... 71 °C	-40 ... 85 °C
DIP A20 T _A 95 °C	-40 ... 85 °C		

5 Electrical data and options

5.1 HART digital communication and 4 ... 20 mA output current

Power supply

The transmitter operates at voltages between 11 and 42 V DC with no load, and is protected against reverse polarity connection (additional load enables operation above 42 V DC).

In the case of the EEx ia version and other intrinsically safe, approved versions, the supply voltage must not exceed 30 V DC.

Ripple

Maximum permissible supply voltage ripple during communication: According to HART FSK "Physical Layer" specification rev. 8.1.

Load limitations

Total loop resistance with 4 ... 20 mA and HART:

$$R(k\Omega) = \frac{\text{Voltage supply} - \text{Minimum operating voltage (VDC)}}{23.6 \text{ mA}}$$



Note

A minimum of 250 Ω resistance is required for HART communication.

LCD display (optional)

Digital, graphic LCD display for customized visualization of:

- Gauge pressure/absolute pressure
- Output current in mA or %, or
- HART output (freely assigned start/end values and unit)

Diagnostic messages, alarms, errors, and measuring range upper limit violations are also displayed.

In addition, the LCD display can be used to configure and parameterize the transmitter using 4 buttons.

Output signal

Two-wire 4 ... 20 mA output

HART® communication provides digital process variables (% , mA, or engineering units) superimposed on the 4 ... 20 mA signal (protocol in accordance with Bell 202 FSK standard).

Output current limits (according to NAMUR standard)

Overload condition:

- Lower limit: 3.8 mA (can be configured up to 3.5 mA)
- Upper limit: 20.5 mA (can be configured up to 23.6 mA)

Alarm current

Min. alarm current: Can be configured from 3.5 ... 4 mA, default setting: 3.5 mA

Max. alarm current: Can be configured from 20 ... 23.6 mA, default setting: 21 mA

Default setting: High alarm current

SIL: Functional safety (optional)

According to IEC 61508/61511

Device with certificate of conformity for use in safety-related applications, up to and including SIL 2.

6 Measuring accuracy

Reference conditions acc. to IEC 60770

- Ambient temperature $T_U = \text{Constant}$, in range: 18 ... 30 °C (64 ... 86 °F)
- Relative humidity = Constant, in range: 30 ... 80 %
- Atmospheric pressure $P_U = \text{Constant}$, in range: 950 ... 1,060 mbar
- Span based on zero position
 - Transmitter with ceramic or Hastelloy isolating diaphragm
- Filling liquid: Silicone oil
- Supply voltage: 24 V DC
- Load with HART: 250 Ω
- Transmitter not grounded
- Characteristic setting: Linear, 4 ... 20 mA

Unless otherwise specified, errors are given as a percentage of the span value.

The accuracy of the measurement in relation to the upper range limit (URL) is affected by the turndown (TD); i.e., the ratio of the upper range limit (URL) to the set span (URL/span).

i Important

Select the transmitter sensor with the smallest possible turndown. This optimizes the accuracy of the measurement.

Dynamic behavior (according to IEC 61298-1)

Reaction time:	100 ms
Time constant (63 %)	150 ms (for all sensors)

Measuring error (for terminal based conformity)

Percentage of set span, consisting of non-linearity, hysteresis, and non-reproducibility.

Turndown	Measurement error
1:1 to 10:1	$\pm 0.15 \%$
>10:1	$\pm (0.15 + 0.005 \times \text{TD} - 0.05) \%$

Optional

Turndown	Measurement error
1:1 to 10:1	$\pm 0.10 \%$
>10:1	$\pm (0.10 + 0.005 \times \text{TD} - 0.05) \%$

7 Operating influences

Thermal change in ambient temperature on the zero signal and span (turndown up to 6:1), in relation to the set span

Range	Maximum effect on zero signal and span
-10 ... 60 °C (14 ... 140 °F)	All measuring ranges $\pm(0.2 \% \times \text{TD} + 0.2 \%)$
-40 ... -10 °C (-40 ... 14 °F)	All measuring ranges $\pm \left(\frac{0.1\%}{10 \text{ K}} \times \text{TD} + \frac{0.1\%}{10 \text{ K}} \right)$
60 ... 85 °C (140 ... 185 °F)	

Temperature coefficient (T_K)

Effect of the ambient temperature per 10 K (but limited to the maximum effect of the temperature change, see previous information). This information refers to the set span.

Range	Effect on zero signal and span
-10 ... 60 °C (14 ... 140 °F)	Sensor code C/F: $\pm(0.15 \% \times \text{TD} + 0.15 \%)$ Sensor code L/D/U/R/V: $\pm(0.05 \% \times \text{TD} + 0.05 \%)$

Temperature limit for white oil, refer to "Operating limits" section

Power supply

Within the specified limits for the voltage/load, the total effect is less than 0.001 % of the upper range limit per volt.

Load

Within the specified load/voltage limits, the total effect is negligible.

Electromagnetic fields

Total effect: Less than 0.3 % of span between 80 and 1,000 MHz and at field strengths of up to 10 V/m, when tested with unshielded cables, and either with or without a display.

Long-term stability

$\pm(0.10 \times \text{TD}) \% / \text{year}$.

Vibration effect

$\pm(0.10 \times \text{TD}) \% \text{ acc. to IEC 61298-3}$.

Total Performance ¹⁾

In range -10 ... 60 °C (14 ... 140 °F):
0.42% of the set span (TD 1:1)

$$E_{perf} = \sqrt{(E_{\Delta 91} + E_{\Delta 92})^2 + E_{lin}^2}$$

E_{perf} = Total performance ¹⁾

$E_{\Delta 91}$ = Zero effect of ambient temperature

$E_{\Delta 92}$ = Span effect of ambient temperature

E_{lin} = Measuring accuracy

¹⁾ The total performance includes the measurement error (non-linearity including hysteresis and non-reproducibility), as well as the thermal change in the ambient temperature on the zero signal and span.

8 Technical specification



Important

Refer to the order information sheets to check the availability of different versions of the relevant model.

Materials

Isolating diaphragms ¹⁾	Ceramic (AL ₂ O ₃) gold-coated; Hastelloy C276™; Hastelloy C276™ gold-coated, Stainless steel (1.4435/316L)
Process connection ¹	Stainless steel (1.4404/316L)
Gasket ¹ (for sensor code C, F only)	Viton™, perfluoroelastomer, Buna (NBR)
¹ Transmitter parts in contact with the medium	
Sensor filling liquid	Silicone oil, inert filling (carbon fluoride), white oil (FDA)
Mounting bracket	Stainless steel
Sensor housing	Stainless steel (1.4404/316L)
Electronics housing and cover	Stainless steel (1.4404/316L)
Filter for atmospheric ventilation	Filter housing: Plastic (standard), stainless steel (code EA, AB) Filter material: Polyamide (PA)
Inspection glass for cover LCD display	Polycarbonate, Makrolon 6557
O-ring cover	EPDM
Name plate	Plastic data plate attached to the electronics housing

Calibration

Standard	0 to upper range limit (URL)
Optional	To specified span

Optional accessories

Mounting bracket	For vertical and horizontal 60 mm (2") pipes or wall mounting
LCD display	Graphical display, pluggable and rotatable design
Additional tag for indicating measuring points	Tag with wire (both stainless steel) attached to the transmitter, with a maximum of 30 characters including spaces
Cleanliness level for oxygen applications	
Certificates (test, design, characteristics, material traceability)	
Language of operating instructions	

™ Hastelloy is a Cabot Corporation trademark.

™ Viton is a DuPont de Nemours trademark.

Process connections

1/2 - 14 NPT internal or external thread; DIN EN 837-1 G 1/2 B or G 1/2 B (HP) for convex seal; front-bonded diaphragm; for installation in ball valve.

Electrical connections

- M16 x 1.5 tap hole with cable gland (cable diameter approx. 5 ... 10 mm), directly on housing, or
- M20 x 1.5 (via adapter) with cable gland (cable diameter approx. 6 ... 11 mm), or
- 1/2 - 14 NPT (via adapter) without cable gland, or
- Harting Han plug connector (with mating plug (socket outlet, for wire cross sections of 0.75 ... 1 mm² and cable diameters of 5 ... 11 mm)), or
- Miniature plug connector (without mating plug (socket outlet))

Terminals

HART version: Two connections for signal/auxiliary power, for wire cross sections of 0.5 ... 1.5 mm² (16 AWG).

Grounding (optional)

External ground terminal for wire cross sections of up to 4 mm² (12 AWG).

Installation position

The transmitter can be installed in any position.

Weight (without options)

- Approx. 0.7 kg
- Packaging adds 650 g

Packaging

Carton with dimensions of approx. 240 x 140 x 190 mm (9.45 x 5.51 x 7.48 inches).

9 Configuration

9.1 Transmitter with HART communication and 4 ... 20 mA output current

Standard configuration

Transmitters are set to the customer's specified span at the factory. The set range and measuring point number are provided on the name plate. If this data has not been specified, the transmitter will be delivered with the following configuration:

4 mA	Zero position
20 mA	Upper range limit (URL)
Output	Linear
Damping	0.1 sec.
Transmitter failure mode	21 mA
Optional LCD display	0 ... 100 %

Any or all of the configurable parameters listed above - including the upper and lower range limit values - can easily be changed using the optional LCD display, a HART handheld communicator, or a PC running the configuration software SMART VISION with DTM for 2600T.

10 Mounting dimensions (not design data)

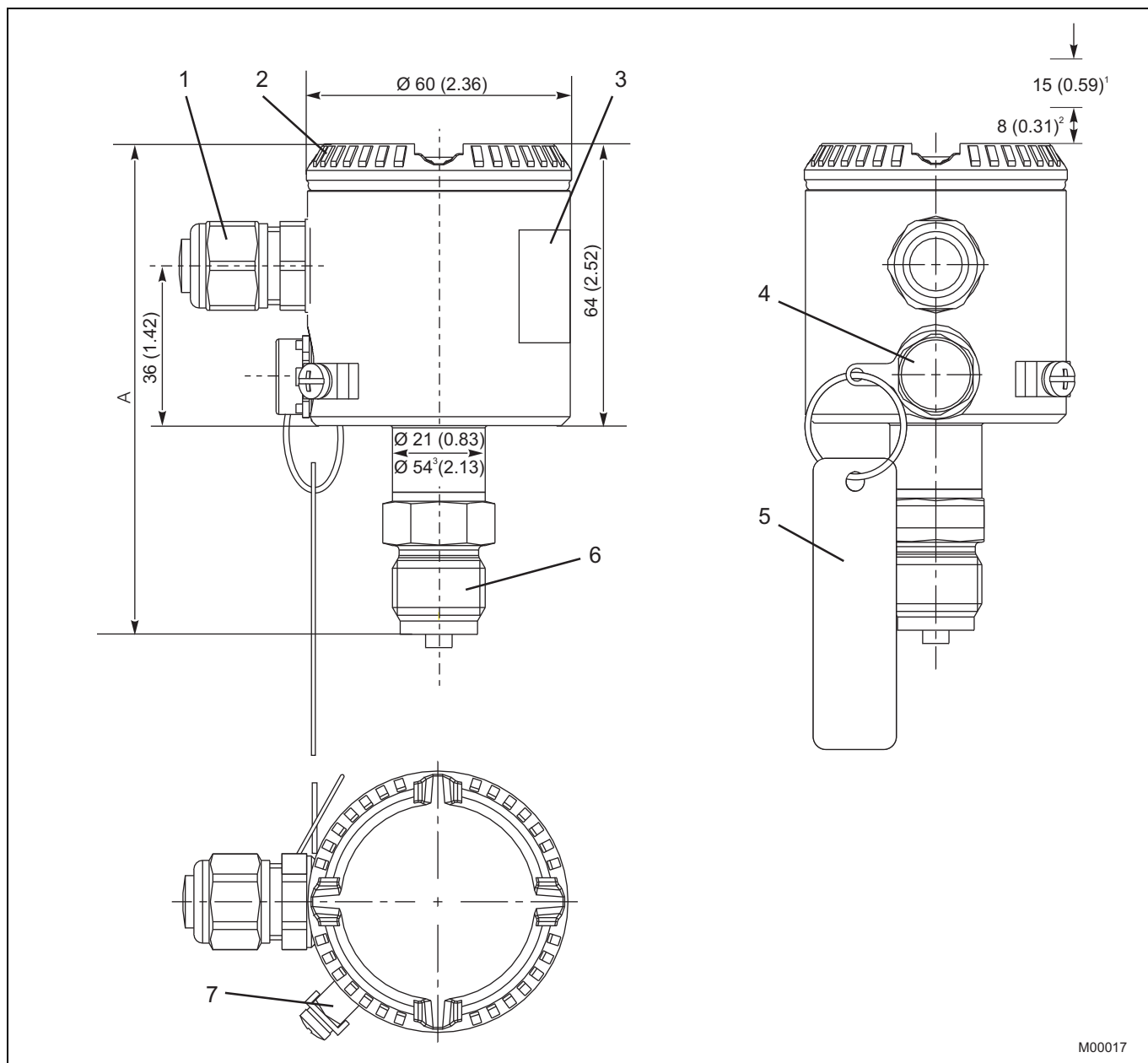

M00017

Fig. 1: (Dimensions in mm / inches)

- 1 Electrical connection
- 2 Housing cover
- 3 Name plate
- 4 Filter for atmospheric ventilation
- 5 Tag plate (optional)
- 6 Process connection
- 7 Grounding / equipotential bonding terminal (optional)

¹ Space for removing the cover required

² With LCD display

³ Dimensions of sensor code C, F

Dimension "A" is dependent on the process connection:

Process connection	
½ -14 NPT male thread	111 (4.37)
½ -14 NPT female thread	106 (4.17) / (110 (4.33) sensor V)
DIN EN 837-1 G ½ B	111 (4.37)
DIN EN 837-1 G ½ B (HP) for connections with convex seal	121 (4.76)

10.1.1 Design with "LCD display" and "Harting Han connector" options

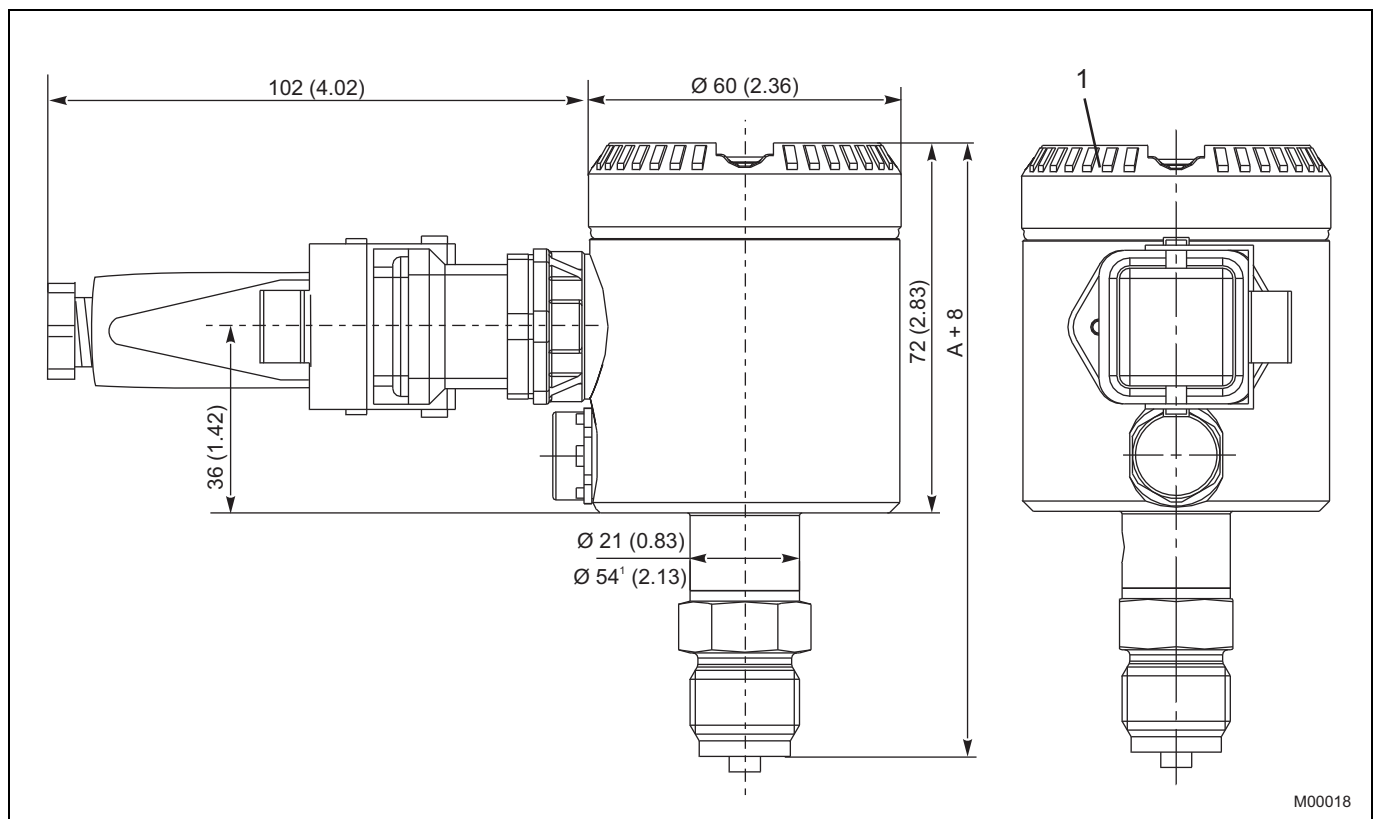

Fig. 2: Dimensions in mm (inches)
 1 Housing cover for LCD display

1) Dimensions for sensor code C, F

Dimension "A" is dependent on the process connection:

Process connection	mm (inches)
½ - 14 NPT male thread	111 (4.37)
½ - 14 NPT female thread	106 (4.17)/(110 (4.33) sensor V)
DIN EN 837-1 G ½ B	111 (4.37)
DIN EN 837-1 G ½ B (HP) for connections with convex seal	121 (4.76)

10.1.2 Transmitter with front-bonded diaphragm

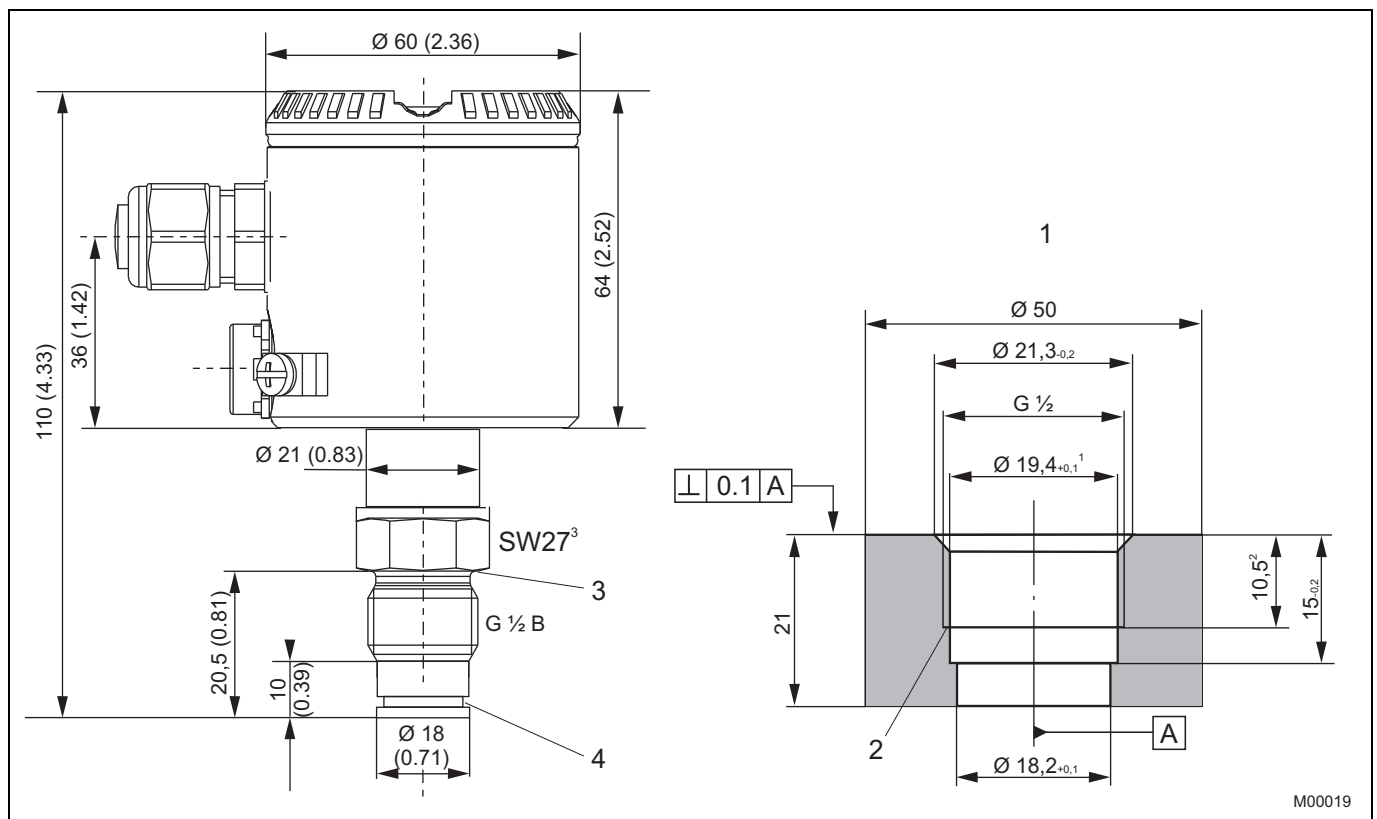

Fig. 3: Dimensions in mm (inches)

- | | | | |
|---|--|---|---|
| 1 | Welded connections/tapped hole for front-bonded diaphragm, part no. 284903 | 3 | Groove for gasket DIN 3869 - 21 18.5 x 23.9 x 1.5 |
| 2 | No burrs | 4 | Groove for O-ring 15 x 2 |

1) Bevel after cutting threads

2) Minimum dimension

3) Wrench size 27

10.1.3 Transmitter with ball valve connection

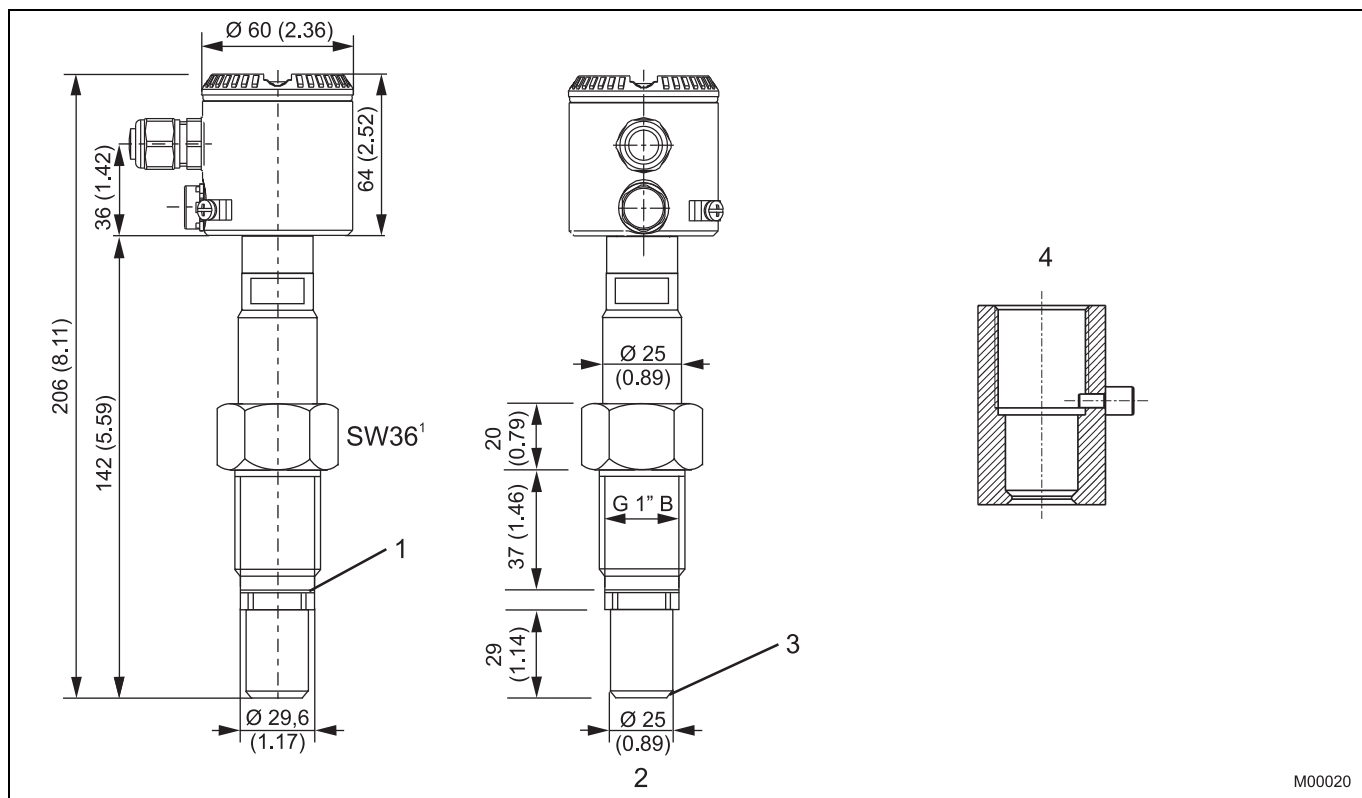

M00020

Fig. 4: Dimensions in mm (inches)

- 1 Shim
- 2 Diaphragm diameter: ~ 20 mm (0.79 inches)
- 3 Conical seal, metal/metal, diaphragm is process-bonded
- 4 Weld-in sleeve G 1", part no.: 789516

1) Wrench size 36

10.1.4 Mounting option with bracket

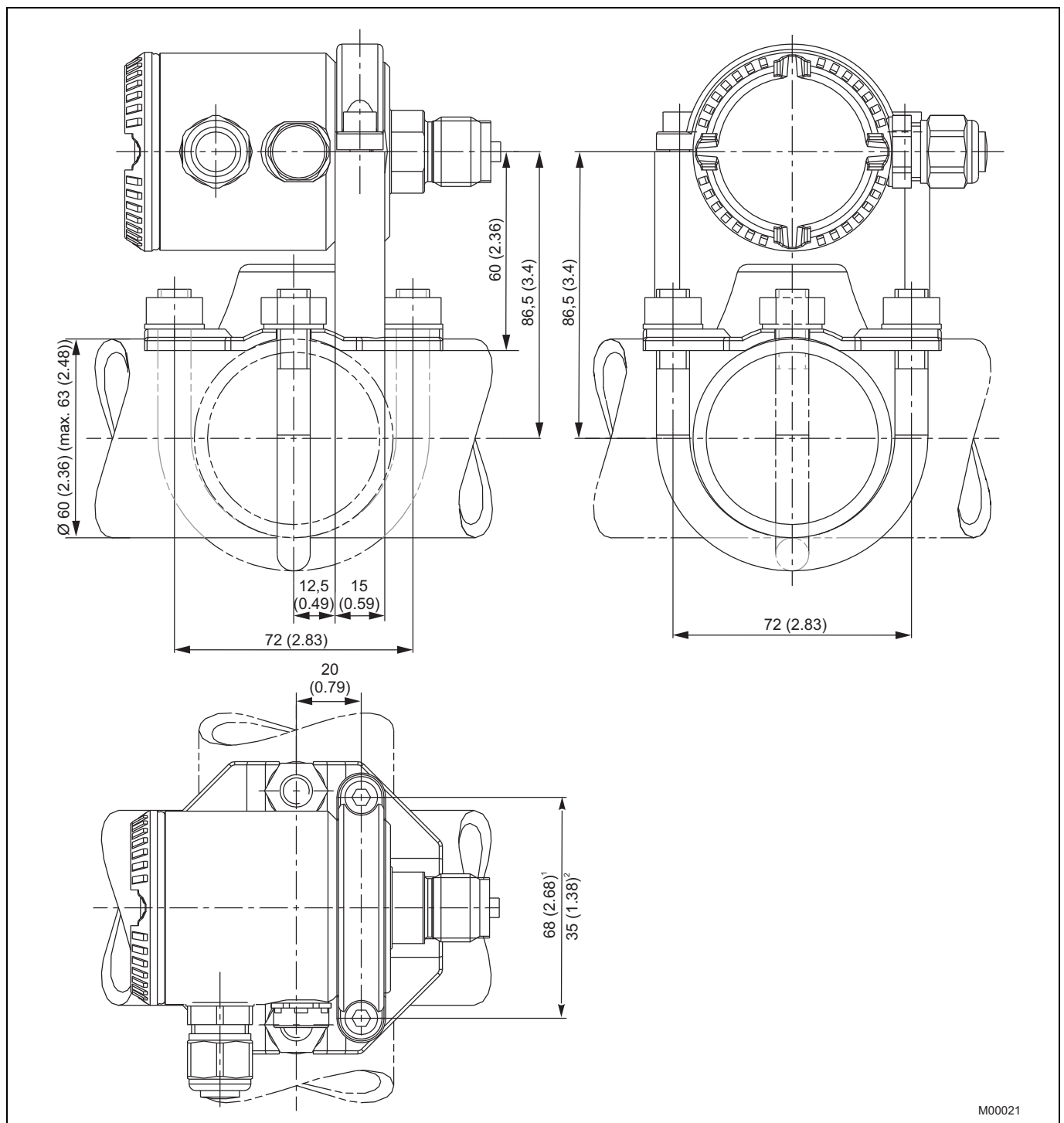

M00021

Fig. 5: Pipe/wall mounting (dimensions in mm (inches))

¹ Dimensions for sensor code C, F

² Sensor code L, D, U, R, V



Important

The bracket for wall or pipe installation has four holes with a \varnothing of 10.5 mm. The holes are arranged in a square and spaced 72 mm away from one another.

11 Electrical connections

11.1 Standard terminal strip

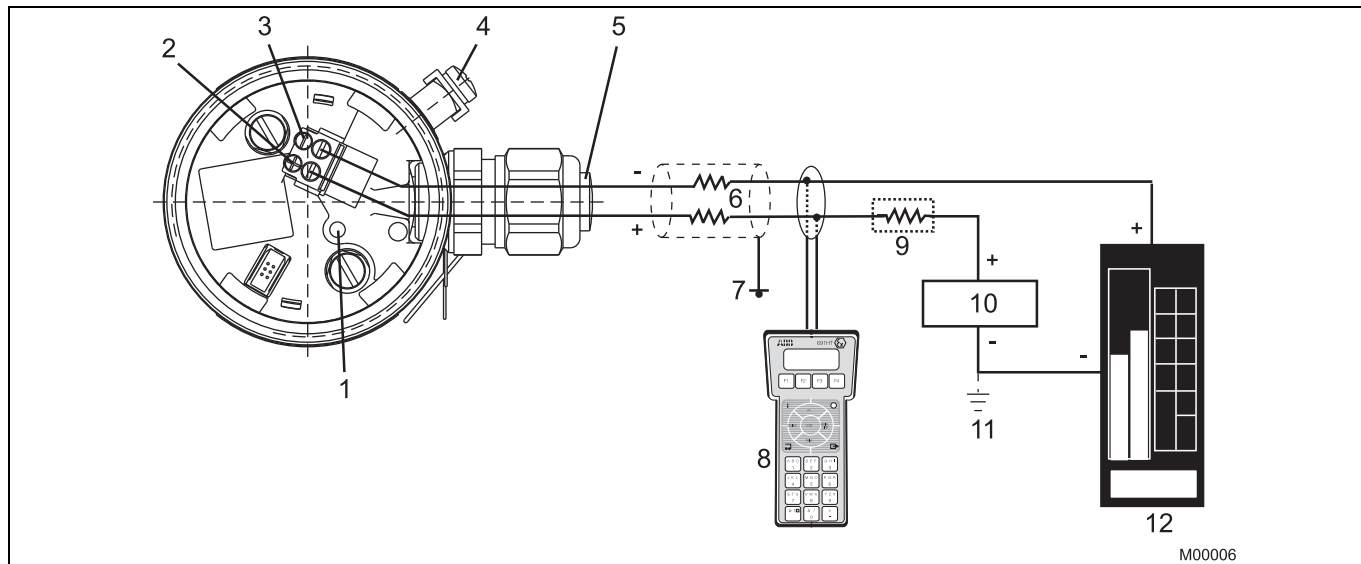

Fig. 6

- | | |
|---|----------------------------|
| 1 Pushbutton for lower/upper range limit values | 6 Line load |
| 2 + Signal screw terminals for leads with 0.5 ... 1.5 mm ² cross section | 7 Ground |
| 3 - Signal screw terminals for leads with 0.5 ... 1.5 mm ² cross section | 8 Handheld terminal |
| 4 Grounding/equipotential bonding terminal (optional) | 9 Resistor with min. 250 Ω |
| 5 Cable entry | 10 Voltage source |
| | 11 Optional ground |
| | 12 Receiver |

11.2 Optional plug connectors

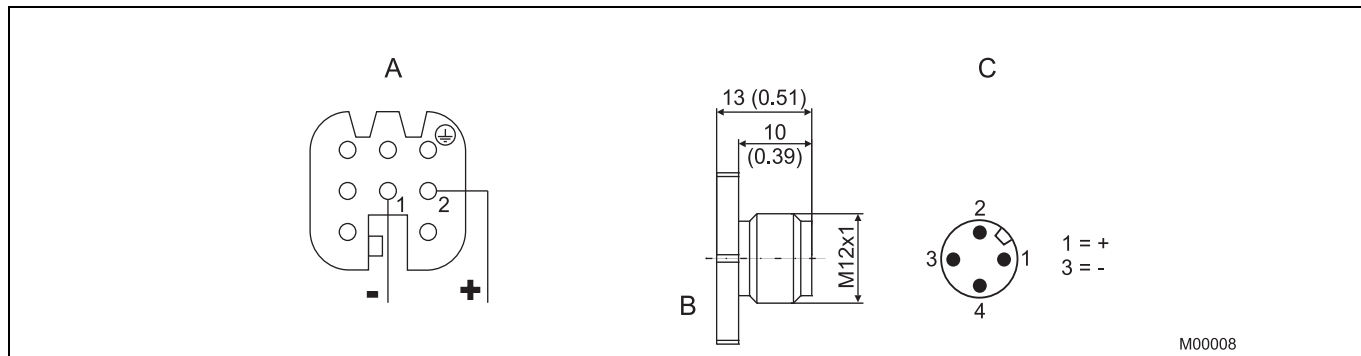

Fig. 7: Dimensions in mm (inches)

- | | |
|--|---------------------------------|
| A Harting Han 8D (8U) socket insert for mating plug supplied (view of sockets) | C M12 x 1 miniature plug (pins) |
| B Mating plug (socket); not supplied | |

Model 261GS for gauge pressure, Model 261AS for absolute pressure, standard overload capability

12 Ordering information

12.1 Ordering information for model 261GS/261AS

Gauge Pressure Transmitter			Variant digit No.	1	6	7	8	9	10	11	12	Code				
261GS	Base accuracy 0.15 %	Catalog No.	261GS-													
Sensor-Span limits			Overpressure limit													
0.3...6 kPa	3...60 mbar	1.2...24 in H ₂ O	1 MPa, 145 psi													
2...40 kPa	20...400 mbar	8...160 in H ₂ O	1 MPa, 145 psi													
12.5...250 kPa	125...2500 mbar	50...1000 in H ₂ O	0.5 MPa, 72.5 psi													
50...1000 kPa	0.5...10 bar	7.25...145 psi	2 MPa, 290 psi													
150...3000 kPa	1.5...30 bar	21.7...435 psi	6 MPa, 870 psi													
500...10000 kPa	5...100 bar	72.5...1450 psi	20 MPa, 2900 psi													
3000...60000 kPa	30...600 bar	435...8700 psi	90 MPa, 13050 psi													
Absolute Pressure Transmitter			Catalog No.	261AS-												
261AS			Base accuracy 0.15 %			Overpressure limit										
Sensor-Span limits			Overpressure limit													
0.3...6 kPa	3...60 mbar	2.25...45 mmHg	1 MPa, 145 psi													
2...40 kPa	20...400 mbar	15...300 mmHg	1 MPa, 145 psi													
12.5...250 kPa	125...2500 mbar	93.8...1875 mmHg	0.5 MPa, 72.5 psi													
50...1000 kPa	0.5...10 bar	375...7500 mmHg	2 MPa, 290 psi													
150...3000 kPa	1.5...30 bar	21.7...435 psi	6 MPa, 870 psi													
500...10000 kPa	5...100 bar	72.5...1450 psi	20 MPa, 2900 psi													
Diaphragm material			Fill fluid													
Hastelloy C276™	6)	Siliconoil	NACE	2)												
Hastelloy C276™ gold-plated		Siliconoil	NACE	2)												
AISI 316L ss / 1.4435		Siliconoil	NACE	2)												
		only for front bonded diaphragm														
Hastelloy C276™		Carbon fluoride	NACE	1, 2)												
Hastelloy C276™ gold-plated		Carbon fluoride	NACE	1, 2)												
AISI 316L ss / 1.4435		Carbon fluoride	NACE	2)												
		only for front bonded diaphragm														
Hastelloy C276™		White oil (FDA)	NACE	2)												
AISI 316L ss / 1.4435		White oil (FDA)	NACE	2)												
		only for front bonded diaphragm														
Ceramic		No filling	NACE	3)												
Process connection material / Process connection			6)													
AISI 316L ss / 1.4404		1/2-14 NPT female	NACE													
AISI 316L ss / 1.4404		DIN EN 837-1 G 1/2 B	NACE													
AISI 316L ss / 1.4404		G 1/2 front bonded diaphragm	NACE	2)												
AISI 316L ss / 1.4404		1/2-14 NPT male	NACE													
AISI 316L ss / 1.4404		DIN EN 837-1 G 1/2 B (HP) for convex seal	NACE	2)												
AISI 316L ss / 1.4404		for ball valve connection	NACE	2)												
Gasket																
Viton™			NACE	1, 3)												
Perfluorelastomer (P _{max} = 0.6 MPa)			NACE	3)												
Buna				3)												
None			NACE	2)												
Electronic housing																
Housing material			Electrical connection													
AISI 316L ss / 1.4404		M16 x 1.5 (with cable gland made of plastic)														
AISI 316L ss / 1.4404		1/2-14 NPT (without cable gland)														
AISI 316L ss / 1.4404		M20 x 1.5 (with cable gland made of plastic)														
AISI 316L ss / 1.4404		Harting Han connector														
AISI 316L ss / 1.4404		Miniature-connector														
Output / Additional options																
HART digital communication and 4...20 mA			No additional options													
HART digital communication and 4...20 mA			Options requested													
			(to be ordered by "Additional ordering code")													

1) suitable for oxygen applications

6) Wetted parts

2) not available with sensor range 60 and 400 mbar

3) only available with sensor range 60 and 400 mbar

4) select connector type with additional ordering code

5) not available for electrical connection with connector

12.2 Additional ordering information for model 261GS/261AS

261GS , 261AS	Code			
Electrical certification				
ATEX Group II Category 1/2 G – Intrinsic Safety EEx ia	EH			
ATEX Group II Category 1/2 G and 1/2 D – Intrinsic Safety EEx ia	5) EL			
Factory Mutual (FM) – Intrinsically Safe	5) EA			
Canadian Standard Association (CSA) – Intrinsically Safe	5) ED			
NEPSI Ex ia IIC T-T6 gas	X3			
NEPSI Ex ia IIC T-T6 gas & dust	X4			
Integrated digital display (LCD)				
With integrated LCD display	L1			
Electronic housing accessories				
Housing with external ground terminal	AA			
Cable gland M16 x 1.5 / M20 x 1.5 and atmosphere ventilation of metal	AB			
Mounting bracket (shape and material)				
For pipe mounting stainless steel	B2			
For wall mounting stainless steel	B4			
Applications				
Oil and grease-free for oxygen measurement (O ₂) (only available with carbon fluoride fill and for sensor code C, F - Viton gasket) P _{max} = 21 MPa/210 bar/3045 psi, T _{max} = 60 °C/140 °F	P1			
Operating Instruction				
German	M1			
Italian	M2			
French	M4			
English	M5			
Swedish	M7			
Russian	MB			
Additional tag plate				
Stainless steel (Laser labeled, max. 30 characters)	I1			
Certificates / Approvals				
Inspection certificate EN 10204-3.1 of calibration	C1			
Inspection certificate EN 10204-3.1 of the cleanliness stage	C3			
Inspection certificate EN 10204-3.1 of helium leakage test of the sensor module	C4			
Inspection certificate EN 10204-3.1 of the pressure test	C5			
Confirmation of compliance with the order EN 10204-2.1 of instrument design	C6			
SIL2 - Declaration of conformity	CL			
MVO-approval (only with fill fluid white oil)	CR			
Non-linearity 0.1 % with calibration record	CQ			
Material certificates				
Confirmation of compliance with the order EN 10204-2.1 of process wetted parts	H1			
Inspection certificate EN 10204-3.1 for pressure-bearing process wetted parts with analysis certificates as material verification (minor parts with Factory Certificate acc. to EN 10204)	H3			
Test report EN 10204-2.2 for pressure bearing process wetted parts	H4			
Connector				
Miniature connector M12 x 1 (without mating female plug)	U2			
Harting Han 8D (8U) – straight entry	7) U3			

5) not available for electrical connection with connector

7) only available for electrical connection with Harting Han connector and output HART

13 Standard scope of delivery (changes may be made by using additional ordering code)

- For general-purpose applications (no Ex applications)
- No display, no mounting bracket
- English-language operating instructions; English and German-language labels
- Configuration with kPa and °C units
- No test, inspection, or material certificates

Unless otherwise specified prior to manufacture, the customer shall be responsible for the selection of suitable parts that make contact with the medium and appropriate filling liquids in order to ensure compatibility with the relevant process medium.

Contact us

ABB Ltd.

Process Automation

Howard Road, St. Neots
Cambridgeshire, PE19 8EU
UK

Phone: +44 (0)1480 475321

Fax: +44 (0)1480 217948

ABB Inc.

Process Automation

125 E. County Line Road
Warminster PA 18974
USA

Phone: +1 215 674 6000

Fax: +1 215 674 7183

ABB Automation Products GmbH

Process Automation

Schillerstr. 72
32425 Minden
Germany

Phone: +49 551 905-534

Fax: +49 551 905-555

www.abb.com

Note

We reserve the right to make technical changes or modify the contents of this document without prior notice. With regard to purchase orders, the agreed particulars shall prevail. ABB does not accept any responsibility whatsoever for potential errors or possible lack of information in this document.

We reserve all rights in this document and in the subject matter and illustrations contained therein. Any reproduction, disclosure to third parties or utilization of its contents in whole or in parts – is forbidden without prior written consent of ABB.

Copyright© 2010 ABB

All rights reserved