



Pressure and Temperature Switches

C and W - series switches

The 'User-Friendly generation' of **BETA Pressure and Temperature Switches**



Safety:

- Safe, secure electrical hookup by clamp terminals
- Standard earth terminal
- IP 66 enclosure (NEMA 4X)
- Solid cover with gasket and captive screws

Reliability:

- Highest overrange protection
- Spring loaded piston, excellent resistance against shock and vibration
- Flexible stainless steel mounting bracket to avoid pipe strains on the instrument to cause shift of setpoint

Product Approvals:

- Complete W-Series is explosion safe certified in EU (ATEX), in USA (FM), in Canada (CSA), in Russian Customs Union (CUTR 012), world wide IECEx. C-series Option i is intrinsically safe certified in EU, in USA (FM), in Canada (CSA), in Russian CU and world wide IECEx. All switches are certified acc. PED. All switches are SIL 2 certified.

Quality and Factory approvals:

- DNV certified Quality Assurance according to ISO 9001 – 2015 and ISO 14001 - 2015, covers all switch manufacturing, engineering and design.
- TÜV: PED Module D, cert. CE 0035
- DEKRA: ATEX Annex VII, CE 0344

Economy:

- A wide range of wetted process materials enable proper selection for any application.

Service:

- The international BETA sales network backs up this high quality product with equally high quality service.

Benefits:

- Our products are distinguished by highest reliability and are used in virtually any sector of industry. Highest quality and worldwide certification of our products for safety-critical applications ensure reliable monitoring of your plant, equipment or installation.
- *BETA safety switches are assembled according to your requirements and are available in more than 10 million versions. Your special request might be a standard for us. Please contact us to discuss your requirements*

- "We will be pleased to advise you" -



The BETA principle:

“A high quality, self-aligning springloaded/- piston sensor is the heart of each BETA switch. The limited piston travel transmits pressure at the process diaphragm directly to the microswitch, with no intervening linkages or mechanisms while providing full protection against high overrange pressure”.

“The piston sensor is isolated from the process fluid by a diaphragm and static O-ring seal and retained by a process connection port. These (3) are the only process wetted parts and are available in an extensive range of materials.”()*

(*) A BETA vacuum switch contains also a vacuum piston and spring (SS 316) on the wetted parts side.

The BETA SWITCH has “DESIGNED-IN” reliability.

- The “**User Friendly Generation**” is no idle boast. BETA can – *and always will* – supply the best - instrumentation for the given conditions.
- Many years of close attention to our customer’s requirements have resulted in a vast experience of virtually all known switch applications.
- Major users all over the world, in all areas of industry, already enjoy the benefits of **BETA’s “User Friendly” Switches.**

* **BETA manufactures high quality instruments** to meet **all of your requirements.**



Stainless steel screws throughout

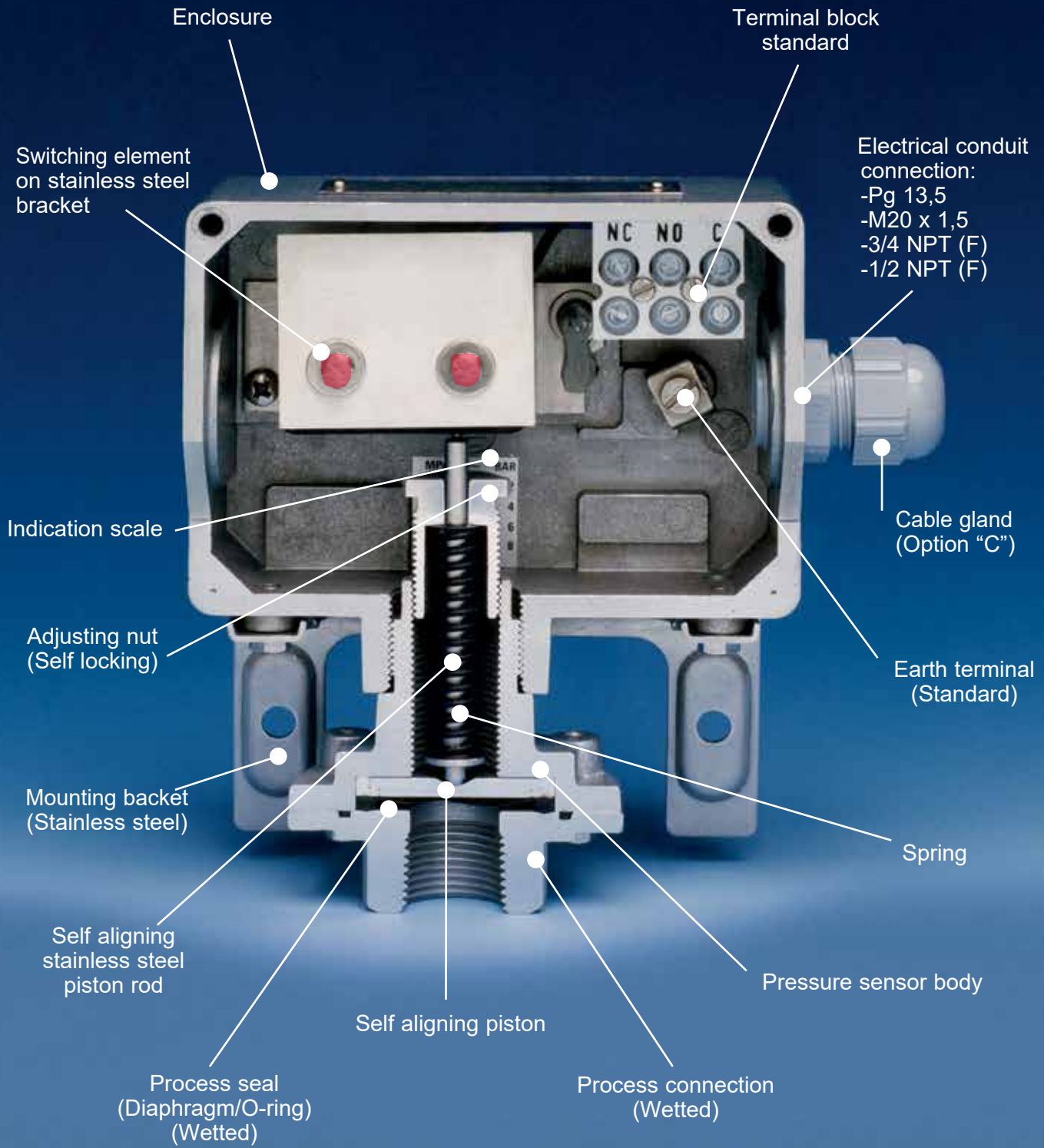

GUIDE OF HOW TO SELECT YOUR BETA SWITCH

BETA uses a simple and logical **modelcode** system for easy, accurate product specification, project coordination, efficient document handling and after sales service.

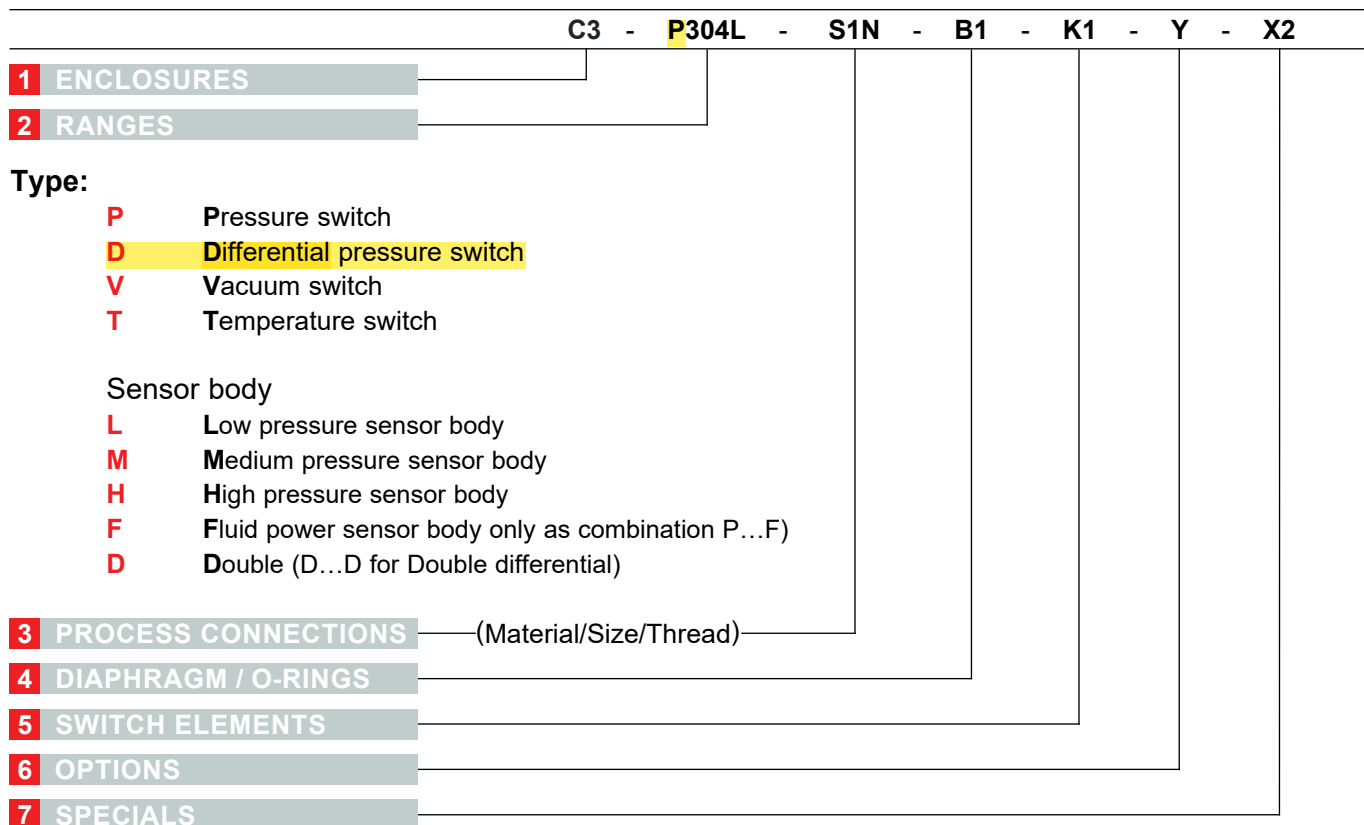

TO SELECT YOUR SWITCH

Follow section **1** through **5**

If required: For "Optional" and "Special" accessories
 Follow section **6** or **7** .

Ambient temperature:

Standard: -30 to +80°C

W-Series for T5 - Ex d: -60 to +70°C **CSA/FM:** -40 to +80°C :

W-Series for T6 - Ex d: -60 to +70°C **CSA/FM:** -40 to +70°C :

C-Series - Ex i: -60 to +70°C

Repeatability:

± 0.2% of Full Range* (measured at 68°F ambient temperature
 acc. to ANSI/I.S.A.-S51.1-1979).

Tagging & Setting:

BETA will free of charge, add your tag no. (Max. 14 digits) on the nameplate and set the pressure switches at desired setpoint if this is requested on your order.

Temperature switches can also be set at an additional charge.

Limited Factory Warranty:

36 months from Ex-Works date Rijswijk/ - The Netherlands
 excluding any wetted parts

* For standard BETA switch (Switch with "K1" switching element and "B1" diaphragm/ O-ring).

1 ENCLOSURES

C3 - P304L - S1N - B1 - K1 - Y - X2

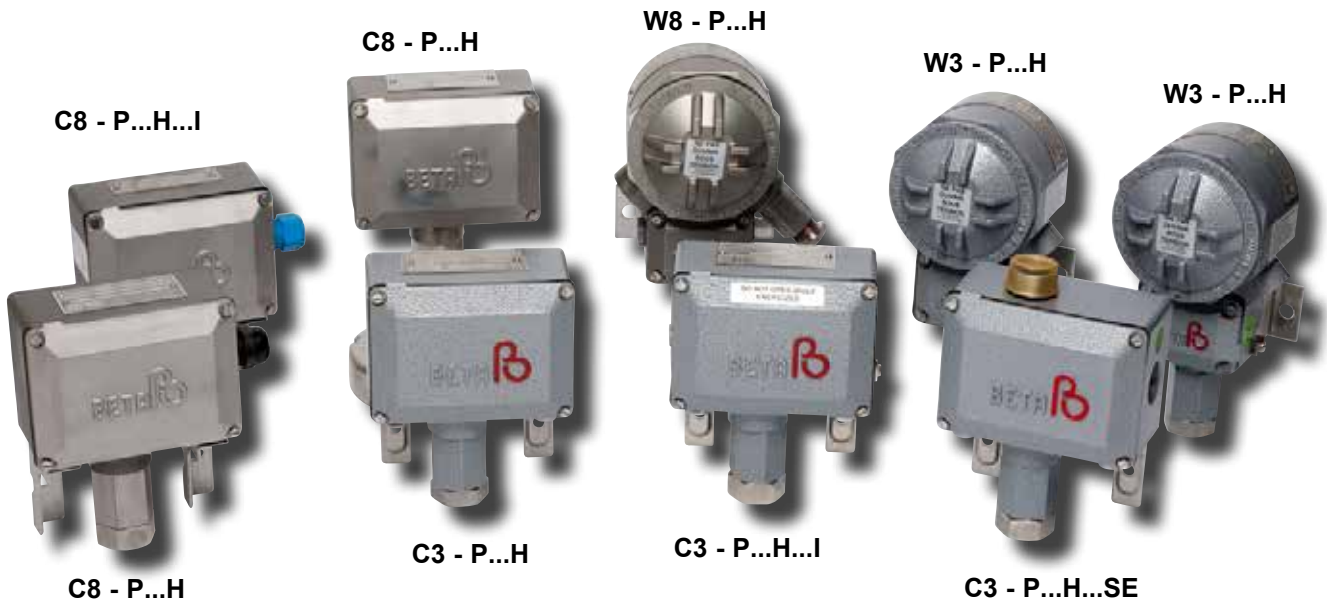

ENCLOSURE CODE	CLASSIFICATION	ELECTRIAL COND. CONN.	MATERIAL	EARTH TERMINAL	TERM. BLOCK	TYPE OF SENSOR						
						Press.	Fluid P.	Vacuum	Diff.	Temp.		
C1	Weathertight (IP66)	PG 13,5 2)	Aluminium	Standard (Internal)	Standard							
C2 3)	Intrinsically safe (with Option "I") Ex ia / ib	M20 x 1,5										
C3 3)	CSA & FM Type 4X	3/4" NPT (F)				√	√	√	√	√		
C4 3)	FM: AEx iex IIC T6 AEx ia IIC T6	1/2" NPT (F)										
C8 3)	CSA: Ex iex IIC T6	M20 x 1,5	316 SS	Standard In- & External	Standard	√	√	√	√	√		
C9	AEx ia IIC T6	3/4" NPT (F)										
W3	Explosion-proof ATEX & IECEx: Ex d IIC T6...T5 Ex tb IIIC T100 C T100°C IP66	3/4" NPT (F)	Aluminium									
W8 3)		M20 x 1,5	316 SS	√	√	√	√	√	√			
W9		3/4" NPT (F)										

** 2" Pipe mount bracket sets available, see page 31.

- 1) Includes SS 316 sensor body and adjusting nut.
- 2) All differentials except D..D - type
- 3) Powder coated acc. to BETA SP025, dry film thickness approx. 70 microns finish hammertone silver/grey high gloss. Due to the nature of hammertone finish color difference might be visible and cannot be avoided.

NOTE:

BETA also manufactures an OEM modelrange called, B2 **BETAMINI**, ask for our separate catalogue (SP.240).

Or check our website www.beta-b.nl at the download section.



2 RANGES for Pressure switches

C3 - **P304L** - S1N - B1 - K1 - Y - X2

“Ranges” given here are valid for setpoints at **increasing pressures** (also vacuum) of the **high end** of the range and **decreasing** for the **low end** of the range.

The “Deadband” values are the max. possible values for a standard micro switch & diaphragm/ O-ring combination. Deadband and varies nearly linear with setpoint between indicated limits of range and should be multiplied by deadband multipliers as given in section 4 and 5, where appropriate. For Fluid Power multiplier acc. to section 5 only.

Selection of other than standard micro switch may influence the lower end of range.

RANGE CODE	ADJUSTABLE RANGE		MAX. DEADBAND		MAX. OVERRANGE PRESSURE	PROOF PRESSURE
P 301 L ¹⁾	[2 - 15]	mbar	[1.1 - 1.9]	mbar	10 bar	15 bar
P 302 L ¹⁾	[10 - 100]	mbar	[2.5 - 3.5]	mbar	30 bar	35 bar
P 304 L	[20 - 240]	mbar	[6 - 9]	mbar		
P 306 L	[20 - 560]	mbar	[6 - 12]	mbar		
P 308 L	[25 - 1300]	mbar	[7 - 15]	mbar		
P 402 M	[100 - 400]	mbar	[15 - 20]	mbar	125 bar	140 bar
P 404 M	[100 - 950]	mbar	[15 - 30]	mbar		
P 406 M	[120 - 2300]	mbar	[16 - 50]	mbar		
P 408 M	[150 - 5400]	mbar	[16 - 90]	mbar		
P 502 H	0.3 - 1.6	bar	[65 - 95]	mbar	200 bar	600 bar
P 504 H	0.4 - 3.5	bar	[65 - 160]	mbar		
P 506 H	0.5 - 9.0	bar	[65 - 330]	mbar		
P 508 H	0.7 - 21.5	bar	[70 - 810]	mbar		
P 706 H	2.5 - 32	bar	0.3 - 1.65	bar		
P 708 H	3.0 - 76	bar	0.3 - 3.75	bar		
P 808 H	4.0 - 170	bar	0.8 - 9.5	bar	300 bar	600 bar
P 908 H	10 - 300	bar	2.0 - 19.5	bar	400 bar	
P 909 H	10 - 350	bar	2.0 - 25	bar		

¹⁾ Only available with L1 -micro switch element.

RANGES for Fluid power switches

RANGE CODE	ADJUSTABLE RANGE		MAX. DEADBAND		MAX. OVERRANGE PRESSURE	PROOF PRESSURE
P 904 F	12 - 55	bar	3.5 - 6.0	bar	650 bar	700 bar
P 906 F	16 - 130	bar	4.0 - 8.5	bar		
P 908 F	20 - 300	bar	6 - 12	bar		
P 918 F	30 - 540	bar	15 - 31	bar		

** Fluid Power switches are to be used on clean, lubricating fluids only.

RANGES for Vacuum switches

RANGE CODE	ADJUSTABLE RANGE ¹⁾ (INCR. VAC. TO PRESS.)		MAX. DEADBAND (VAC. / PRESS.)		MAX. VACUUM		MAX. OVERRANGE PRESSURE		PROOF PRESSURE	
V 301 L ²⁾	[-10 to -3]	[mbar]	[1]	[mbar]	[-500]	[mbar]	+10	bar	+15	bar
V 304 L	[-60/0/+150]	[mbar]	[4/4/6.5]	[mbar]	[-500]	[mbar]	+30	bar	+35	bar
V 404 M	[-400/0/+400]	[mbar]	[16/16/25]	[mbar]	-1	bar	+125	bar	+140	bar
V 406 M	[-980/0/+1000]	[mbar]	[30/30/40]	[mbar]						
V 506 H	-1/0/+6	bar	[80/80/25]	[mbar]	-1	bar	+200	bar	+600	bar

¹⁾ For setpoint around 0 bar gauge, please consult your local representative.

²⁾ Stability of setpoint around 0 bar gauge, is not guaranteed.

2 RANGES for Differential switches

C3 - **D352H** - S1N - B1 - K1 - Y - X2

RANGE CODE	ADJUSTABLE RANGE ¹⁾ DIFF. RANGE		TYPICAL DEADBAND ¹⁾		MAX. STATIC PRESSURE		MAX. OVERRANGE PRESSURE		PROOF PRESSURE	
P 301 L...-D ⁶⁾	[2 - 15]	²⁾ [mbar]	[1,1-1,97]	[mbar]	10	bar	10	⁴⁾ bar	15	bar
D 302 L	[12 - 75]	²⁾ [mbar]	[7]	[mbar]	30	bar	30	³⁾ bar	35	bar
D 304 L	[22 - 180]	[mbar]	[8]	[mbar]						
D 306 L	[25 - 450]	[mbar]	[11]	[mbar]						
D 309 L	[35 - 1250]	[mbar]	[15]	[mbar]						
D 402 M	0.3 - 1.0	bar	0.15	bar	10	bar	140	⁵⁾ bar	140	bar
D 404 M	0.5 - 2.5	bar	0.2	bar	50	bar				
D 406 M	1.0 - 6.0	bar								
D 408 M	1.0 - 14.5	bar								
D 506 M	5 - 20	bar	0.8	bar	100	bar				
D 508 M	10 - 50	bar								
D 608 M	10 - 70	bar								
D 352 H	[80 - 160]	[mbar]	[25]	[mbar]	200	bar				
D 354 H	[100 - 500]	[mbar]	[35]	[mbar]						
D 356 H	[120 - 1450]	[mbar]	[50]	[mbar]						
D 359 H	[150 - 3450]	[mbar]	[75]	[mbar]						

RANGES for Bi-Directional

D 356 D	[100 - 1500]	[mbar]	[35 - 65]	[mbar]	200	bar	200	⁵⁾ bar	200	bar
D 358 D	[100 - 3500]	[mbar]	[45 - 115]	[mbar]						

NOTES:

- 1) Ranges and deadbands are given at 50% of Max. Static pressure.
All differential pressure sensors are sensitive to static pressure, both for setpoint and deadband.
- 2) Range only with L1 micro switch.
- 3) D...L can withstand a differential pressure P-Low max. 1 bar above P-High.
- 4) P 301L...D can withstand a differential pressure P-Low max. 100 mbar above P-High.
- 5) D...M, D...H and D...D can sustain full High and Low-side reversal.
- 6) Only available with G3-enclosure.
- For more details, page 16.

THE FOLLOWING TABLE SHOW THE INFLUENCE FOR INCREASING STATIC PRESSURE:

SENSOR	SETPOINT	DEADBAND
P301L...-D	= + 0.1 mbar/bar	= + 0.1 mbar/bar
D...L	- 0.7 mbar/bar	= - 0.1 mbar/bar
D...M	= + 3 mbar/bar	+ 10 mbar/bar
D...H	- 2 mbar/bar	= - 0.4 mbar/bar

Example:

D...H - type Diff. setpoint: 1 bar (1000 mbar).
If static pressure increases 10 bar then the differential setpoint will be:
(10 times - 2 mbar) = 20 mbar - 1000 mbar = 980 mbar.

NOTE: For differential application outside above ranges consult your BETA Representative.

3 PROCESS CONNECTIONS

C3 - P304L - **S1N** - B1 - K1 - Y - X2

PROCESS CONNECTION SIZE/ CODE	WITH SENSOR ¹⁾	ALUMINIUM		SS 316		MONEL		BRASS	
		NPT	BSP	NPT	BSP	NPT	BSP	NPT	BSP
1/4" F	F								
	L								
	D...L (Low side)	A1N	A1B	S1N	S1B	M1N	M1B	B1N	B1B
	D...L (High Side)								
	H / M / D...M								
D...H / D									
1/2" F	F								
	D... L (High Side)			S2N	S2B	M2N	M2B	B2N	B2B
	H / M / D...M								
1/2" M	L, M & H D...L / M (High Side)			S7N	S7B	M7N	M7B		
1/2" Gauge Connection	H L & M				S7G				
Not for ²⁾ vacuum	1" F			S4N	S4B				
	2" F			S6N	S6B			B6N	B6B
	1" M	M & H D...M			S8N	S8B			

- 1) (Standard) process connection** for "L"ow pressure sensor body : S1N or S1B
 "M"edium & "H"igh pressure sensor body : S1N or S1B
 "F"luid power pressure sensor body : B1N or B1B
 Differential switches: D...H, D...D, D...M : S1N or S1B only
 D...L : A1N or A1B; **For Low side only**
High side: Only "L"-sensor connections

2) Vacuum switches: Process connection size max. 1/2". Vacuum piston & spring (both wetted) standard in 316 SS.

NOTES:

- Process connection according to NACE standards are available, consult your BETA Representative.

Materials such as PVC, Hastelloy, Titanium, special sensor sizes and Teflon lined flanged connections are available on request.



4 DIAPHRAGM / O-RINGS

C3 - P304L - S1N - **B1** - K1 - Y - X2

DIAPHRAGM / O-RING CODE	DIAPHRAGM ⁶⁾	O-RING	USE ¹⁾	DEADBAND MULTIPLIER
B1	Buna-N	Buna-N ²⁾	Standard water / oil (-30°C to +80°C).	1.0
E6	EPDM	EPDM ²⁾	Some hydraulic fluids, steam condensate.	1.0
K5	Kalrez	Kalrez ²⁾	Highly corrosive fluids.	1.5
M1	Monel	Buna-N ⁵⁾	Seawater.	2.0
M2		Viton-A ⁴⁾	Process temperature NOT below <i>minus</i> 10°C. ⁷⁾	
M4		PTFE	Corrosive acids.	
M5		Kalrez	Highly corrosive and permeative acids.	
N3	Neoprene	Neoprene ²⁾	When required.	1.0
P1	PTFE (Polyimide coated with PTFE)	Buna-N	Oil / air / water.	1.5
P2		Viton-A ⁵⁾	Process temperature NOT below <i>minus</i> 10°C. ⁷⁾	
P4		PTFE ⁴⁾	Corrosive acids.	
P5		Kalrez	Corrosive acids.	
S1	SS 316	Buna-N	Permeative gases.	2.0
S2		Viton-A ⁵⁾	Process temperature NOT below <i>minus</i> 10°C. ⁷⁾	
S3		Neoprene	Permeative refrigerant gases.	
S4		PTFE ⁴⁾	Corrosive acids.	
S5		Kalrez	Highly corrosive and permeative acids.	
S6		EPDM	Steam. (Not for steam condensate)	
T1	Tantalum	Buna-N	Highly corrosive and permeative gases and non-acid liquids. Select O-ring as required.	2.0
T2		Viton-A ⁵⁾		
T3		Neoprene		
T4		PTFE ⁴⁾		
T5	Kalrez ^{2) 5)}			
V2	Viton-A	Viton-A	Process temperature NOT below <i>minus</i> 10°C. ⁷⁾	1.5
S0	SS 316	Welded diaphragm	Highly permeative gases. ⁷⁾	3.0
M0	Monel	None ³⁾		

- 1) Wetted parts are suggested for use on the service indicated. However they do not constitute a guarantee to be suitable for a given process against corrosive or permeation since processes vary from plant to plant. Empirical experience by users should be the final guide. The diaphragm / O-ring combinations are for process temperatures of **-30°C to +80°C**, unless otherwise indicated.
For process temperatures beyond these limits please contact your BETA Switch Representative.
- 2) Switches for fluid power applications are limited to these options (O-ring only with 316SS piston).
- 3) Only for 1/4" & 1/2" process connections. **Not available on vacuum switches.** For other sizes and materials, consult your BETA Switch Representative.
- 4) PTFE O-ring **not suitable** for vacuum switches or vacuum surge conditions. (Wetted internal spring of Co-Cr-Ni-Mo alloy, comparable with Elgiloy).
- 5) For process temperature > 100°C, consult your BETA Switch Representative.
- 6) Other diaphragm materials like Hastelloy available, consult your BETA Switch Representative.
- 7) **High temperature** refers to **max. 130°C** at process connection.

4 DIAPHRAGM / O-RINGS

C3 - D352H - S1N - **P1** - K1 - Y - X2

W3 - D...L

W8 - D...L



* Cut-a-away model

Differential Pressure Switches include a similar type of Diaphragm/O-ring combinations as for Pressure Switches, but the following must be considered:

TYPE	STANDARD	FOLLOWING COMBINATIONS ARE POSSIBLE
P301L/ D...L	B1	All except with PTFE O-Ring and Welded diaphragm.
D...M	B1	All diaphragm and O-Ring combinations.
D...H	P1	Metal + TCP.
D...D	P1	Metal + TCP.

Note: Deadband Multiplier for Diaphragm/O-Ring and switching element are similar as for a pressure switch.



5 SWITCHING ELEMENTS

C3 - P304L - S1N - B1 - **K1** - Y - X2

SWITCHING ELEMENT CODE ¹⁾	USE		MAX. RATINGS (RES.)		DEADBAND MULTIPL.	
			VAC.	VDC ⁸⁾	S.P.D.T.	D.P.D.T.
H1 (SL)	Herm. sealed	(Inert gas filled) Dusty, corrosive environment.	125/ 1A	28/ 15A	5.0	6.5
K1 ^{4) 9)}	General-service	Standard.	480/ 15A	28/ 0.5A**	1.0	1.5
L1 ⁴⁾		Standard for P/D301L & P/D302L ranges.	480/ 10A	28/ 0.5A	1.0	-
M1 ¹⁰⁾		Standard DPDT configuration on W-series when required.	250/ 5A	30/ 5A	1.5	3.5
U1 ⁹⁾		Normal DC-service.	480/ 15A	125/ 0.5A	2.5	4.0
G1 ⁴⁾	Low voltage circuit (Gold contacts)	For use in H ₂ S environment and/ or for (EEx) applications. ²⁾	125/ 1A	28/ 0.5A**	1.5	2.0
Y1 ¹⁰⁾			125/ 0.1A	30/ 0.1A	3.0	4.5
O1 ¹⁰⁾	Gold contacts	Environmental proof (IP 67). ²⁾	250/ 0.1A	30/ 0.1A	3.0	4.5
N1 ¹⁰⁾	Silver contacts	Environmental proof (IP 67).	250/ 2A	30/ 2A	3.0	4.5
Z1 ¹⁰⁾	For higher (amb.) temp.	Nickel Alloy spring. For corrosive environment.	250/ 5A	125/ 0.3A	3.0	4.5
R1	Ex. Proof.	ATEX approved. (Std. on Z-series)	250/ 5A	250/ 0.25A	2.5	4.5
SP	Adjustable deadband	Small adjustable deadband.	250/ 15A	-	1 to 3	S.P.D.T. only
SR ³⁾⁵⁾⁶⁾⁹⁾		Wide adjustable deadband.	480/ 20A	-	2 to 6	
SE ³⁾	Manual reset	Actuates automatic on increasing pressure.	480/ 15A	125/ 0.5A	1.5	
SG ³⁾		Actuates automatic on decreasing pressure.	480/ 15A	125/ 0.5A	1.5	
SV ³⁾	DC-service	High DC cap. magnetic blow out.	125/ 10A	125/ 10A	5.0	
SA	Pneumatic AIR Relay ⁷⁾	Normally closed (NC).	For use in explosive atm. Ex II 2G c T6 KEMA 04ATEX4060		Consult BETA Switch Rep.	
SB ³⁾		Normally open (NO).				

- 1) For D.P.D.T. action second code figure should be specified as "2" (Example: K1 = S.P.D.T. / K2 = D.P.D.T.).
- 2) Actual capacitive or inductive load under VDC may influence the setpoint repeatability.
- 3) Not on Differential pressure switches (except for "SR"-micro in "W"-enclosure).
- 4) VDE certified acc. to. DIN EN 61 058-1:1992+A1:1993.
- 5) "SR"-and "H1"-micro switches, with high multiplier, can affect the low end of a range.
- 6) "SR"-micro in combination with metal diaphragm: **standard with option "P"**.
- 7) For pneumatic element (select **C1** or **C8** enclosure) or ask your BETA representative for Air Relay documentation.
- 8) For DC rating resistive loads are stated.
- 9) In "W..." Enclosure max 10A current rating allowed, will be stated on the nameplate.
- 10) Subminiature microswitch, only possible with selection for DPDT configuration for W-enclosure.

** DC rating not U.L. listed, although experience and third party testing confirm the DC voltage ratings. Consult your BETA Switch Representative.

Note:

- Micro switches both for single and double action respectively SPDT and DPDT, are intended to be set for one setpoint and one direction only.
- The deadband reset value is a result of the complete modelcode selection and actual switch assembly, so except for the SR/SP microswitch, the reset switching point is fixed and cannot be controlled by the manufacturer.
- Please keep in mind that even within a series of similar model, the reset switching point can vary.
- Proper application of SR and SP micro switches requires accurate statement of values to the setpoint and required reset setpoint.

If you have any specific question or requirement contact us at: 2sales@beta-b.nl

5 SWITCHING ELEMENTS VS. ENCLOSURES

C3 - P304L - S1N - B1 - **K1** - Y - X2

SWITCHING ELEMENT		ENCLOSURE		
		C1, C2, C3, C4, C8, C9	W3, W8, W9	
		Internal Earth Ground Terminal	Internal & External Earth Ground Terminal	
SPDT SINGLE POLE DOUBLE THROW	SE	3-WAY TERMINAL BLOCK	4-WAY TERMINAL BLOCK	
	SG			
	SP			
	SR			
	SV			
	G1		3-WAY TERMINAL BLOCK	4-WAY TERMINAL BLOCK
	H1 (SL)			
	K1			
	L1			
	U1			
	O1			
N1	3-WAY TERMINAL BLOCK	4-WAY TERMINAL BLOCK		
R1				
M1				
Y1	2 X 3-WAY TERMINAL BLOCK	7-WAY TERMINAL BLOCK		
Z1				
R2				
M2	2 X 3-WAY TERMINAL BLOCK	7-WAY TERMINAL BLOCK		
Y2				
Z2				
G2				
H2				
K2	2 X 3-WAY TERMINAL BLOCK	7-WAY TERMINAL BLOCK		
U2				
O2				
N2	1/4 NPT (F) CONNECTIONS	7-WAY TERMINAL BLOCK		
SA *				
SB *	1/4 NPT (F) CONNECTIONS	7-WAY TERMINAL BLOCK		

	POSSIBLE
--	-----------------

"SA" / "SB" only with C3 enclosure, pneumatic connection (Brass) and C8 enclosure with SS316 connection.

	NOT POSSIBLE
--	---------------------

The standard switching elements are:

- "K1" for C- and W- enclosures.
- "L1" for P301L/ P302L/ D302L range.

6 OPTIONS

C3 - P304L - S1N - B1 - K1 - **Y** - X2

OPTION CODE	DESCRIPTION
B 1)	Industrial cleaning of "wetted" parts for oxygen services.
C	Cable gland (Weather proof IP66, Ex e, Ex i, Ex d in acc. with classification of enclosure).
I	Intrinsically safe application (Ex e, Ex i, Ex d). Only on "C"-Series (90V/ - 3.3A).
M 2)	Vacuum protector plate (Not on Vacuum-, Fluid Power-, D...H- and D...D Switch) (Standard on D...L).
P	Recommended on strong process pulsations. Only on "H"-Sensors. <i>Not in combination with EPDM, Neoprene, Viton-A and Kalrez diaphragms.</i>
S 3)	Stainless steel Tag key ringed to enclosure. Tag has 2 lines (16 characters per line).
V	Fungicidal varnish coating (internal).
Y 4)	Epoxy coating of switch (external). Only in combination with SS 316 process connection. SS Parts are not coated.

1) Option **B** - Oxygen cleaning acc. SP19.

Not possible for D..H ranges/ for G3-P301L-..D and D..L ranges on Hi-side connection only.

2) Option **M** - Is only to intend to provide a limited protection against surge/ vacuum conditions, as which can occur during start-up conditions or repetitive applications (pumps/ compressor). So short occurrences over a limited period of time.

It is not intended for continuous surge/ (full) vacuum conditions over an extended period of time.

Indication:

RANGE	Max. Surge Pressure	Approx. period of time (minutes)
P3..L	-200 mBarg	60
P4..M	-200 mBarg	60
P5-7-8-9..H	-600 mBarg	90

- Values stated here for indicative purpose only, they do not constitute any true value or any kind of warranty.
- Option M - is considered as wetted part and as such is explicitly excluded from the BETA factory warranty.

Tag no. space on nameplates are added free of charge

3) Standard nameplate **C-Series** : 2 lines with 16 characters or spaces + 1 line with 14 characters or spaces.
W-Series : 1 line with 16 characters or spaces.

4) Air dried system acc. to BETA procedure, dry film thickness approx. 200 µm, finish pearl grey gloss.

7 SPECIALS

C3 - P304L - S1N - B1 - K1 - Y - **X2**

We can incorporate many specials to meet your requirements.

These special requirements are indicated by the letter "X" in the modelcode positioned or at the end of the model number, followed by a figure showing the number of specials.

Example:

"X1" at the end of modelcode reference means **one** special.

"X2" at the end of the modelcode reference means **two** specials have been incorporated.

Details of each special must be specified completely on enquiries and orders.

Example for specials for BETA switches are:

- Flanged connection 3/4" to 3" (ANSI or DIN).
- Range indication in Pa, Kg/cm², mm H₂O or mmHg.
- Breakwire resistor acc E12 range for line monitoring (Only for C-enclosure).
- Hirschmann or Harting Connector.
- Moisture inhibitor.
- Chemical seals.



1 ENCLOSURES

C3 - P304L - S1B - S2 - K1 - Y - X2

See section 1. **Enclosure** on page 5.

2 RANGES

C3 - P304L - S1B - S2 - K1 - Y - X2

See section 2. **Range** on page 6, and 7.

3 PROCESS CONNECTIONS (Material / Size / Thread)

C3 - P304L - S1B - S2 - K1 - Y - X2

See section 3. **Process connections** on page 8.

4 DIAPHRAGM / O-RINGS

C3 - P304L - S1B - S2 - K1 - Y - X2

See section 4. **Diaphragm / O-rings** on page 9 and 10.

5 SWITCHING ELEMENTS

C3 - P304L - S1B - S2 - K1 - Y - X2

See section 5. **Switching Elements** on page 11 and 12.

Selection of your switch is now completed.

If required: For “Optional“ and “Special“ requirements

Options : See section **6. Options**” on page 14.

Specials: See section **7. Specials**” on page 14.

The “User Friendly” generation of BETA switches, offers you a complete range of - **Differential Pressure Switches** -.

LOW RANGE

“D... L”- SERIES

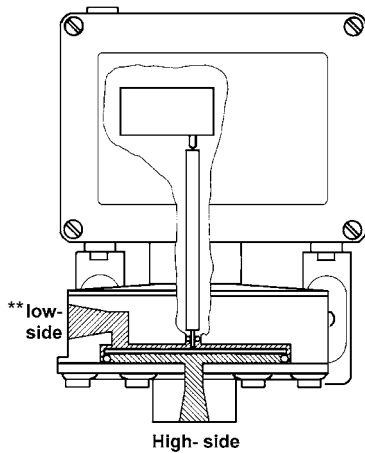

- Principle:** As pressure switch, with sealed Aluminium sensorbody (optional in 316 SS).
- Range:** 12 - 1250 mbar.
Max. Static Pressure: 30 bar.
- Application:** Dry clean air, inert gases and clean non-corrosive fluids and gases.
- Execution:** Weathertight IP 66 (C-enclosure),
 Ex i a/b (C-enclosure + option I),
 Ex d (W-enclosure).

*** Low side only available in 1/4 NPT/ BSP F aluminium or SS 316.*

* “Clean fluids and gases”, must be free of particles > 40µm, filters (not included) are recommended in case of contaminated medium. A differential pressure switch is a “dead end” instrument, so a simple filter with fine mesh will work.

GENERAL PURPOSE

“D...M”- SERIES

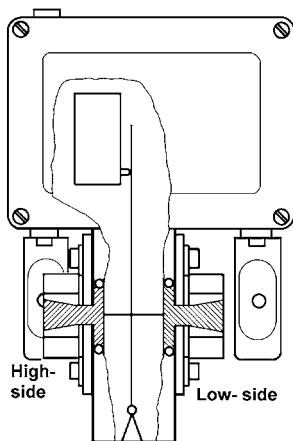

- Principle:** 2 x piston/diaphragm type with separate sealing for High and Low.
- Range:** 0.3 - 70 bar.
Max. Static Pressure: 140 bar.
- Application:** Fluid & gas applications which are chemically compatible and are within the switch range.
- Execution:** Weathertight IP 66 (C-enclosure),
 Ex i a/b (C-enclosure + option I),
 Ex d (W-enclosure).

VERY LOW RANGE

“P301L- .. - D”- SERIES

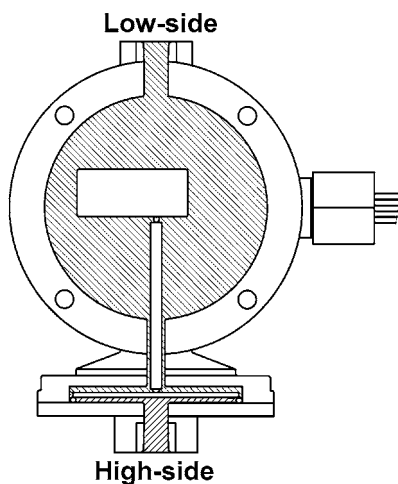

- Principle:** As pressure switch in sealed Aluminium enclosure.
- Range:** 2 - 15 mbar. (With “L1” micro only).
Max. Static Pressure: 10 bar.
- Application:** Dry clean air inert gases (Low side only).
- Execution:** Weathertight IP 66, (G3 enclosure only) with potted wire leads.

LOW RANGE / HIGH STATIC

“D... H”- SERIES

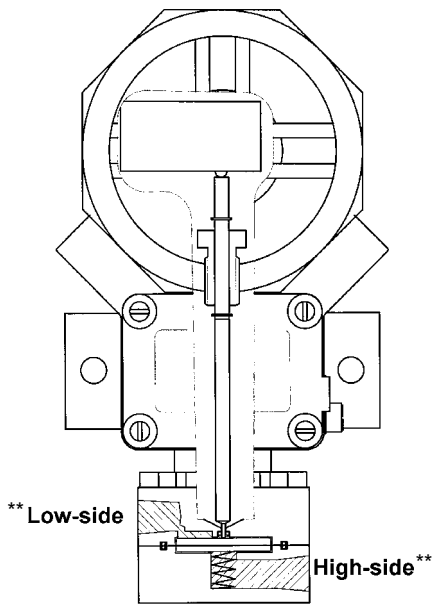

- Principle:** Piston type with single diaphragm, sealed in 316 SS sensorbody.
- Range:** 80 – 3450 mbar
- Max. Static Pressure:** 200 bar
- Application:** Clean fluids and gases*, provided acceptable choice of wetted parts is within our range.
- Execution:** Weathertight IP 66 C-enclosure,
Ex i a/b C-enclosure + option I,
Ex d W-enclosure

*** Low and High side, only available in 1/4 NPT/ BSP F, SS 316.*

LOW RANGE / HIGH STATIC

“D...D”- SERIES

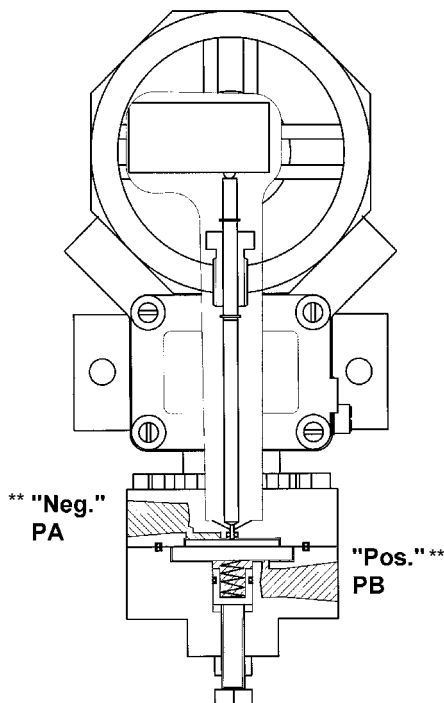

Bi-Directional Differential Pressure Switch

- Principle:** Piston type with single diaphragm, sealed in 316 SS sensorbody.
- Range:** 0,1 – 3,5 bar
- Max. Static Pressure:** 200 bar
- Application:** Clean fluids and gases*, provided acceptable choice of wetted parts is within our range.
- Typical application:** Natural gas pipelines, safe guarding high pressure pipeline valves against being opened at too high differential pressure from either side.
- Execution:** Weathertight IP 66 C-enclosure,
Ex i a/b C-enclosure + option I,
Ex d W-enclosure.

*** Neg./ Pos. side only available in 1/4 NPT/ BSP F, SS 316.*

* “Clean fluids and gases”, must be free of particles > 40µm, filters (not included) are recommended in case of contaminated medium. A differential pressure switch is a “dead end” instrument, so a simple filter with fine mesh will work.

TEMPERATURE SWITCH



The BETA Temperature Switch is a pressure switch enclosure incorporating a sealed 2-phase (vapor/liquid) temperature sensor.

When the temperature of the process increases, the vapor pressure of the liquid increases simultaneously.

If this vapor pressure exceeds the pre-adjusted setpoint of the "pressure" switch, it will actuate the switching element.

- Available as direct- or capillary mount sensor.
- In weathertight and explosion proof models (ATEX approved).
- Fits into most standard thermowells (10,5 mm bore).
- No need for ambient temperature compensation (no setpoint shift).
- Excellent repeatability/small dead-band.
- All 316 stainless steel sensor and capillary (SS armored).
- Filling system of gas/liquid acc. to SAMA-Class II C.

"C" - Series with Direct mount type sensor

EXPLOSION-PROOF TEMPERATURE SWITCH



ATEX, IECEx, CSA & FM, approved up to the highest classification (see page 23).

With the W-enclosure or the C-enclosure Option i, the BETA Temperature Switch is approved for ATEX, IECEx, FM, CSA and several more, a.o. acc. EN 60079 standards

"W" - Series with Capillary type sensor

TEMPERATURE SWITCHES

1 ENCLOSURES

C3 - T548H - D00 - S0 - K1 - Y - X2

W3 - T...H-D00



C3 - T...H-D00

W3 - T...H-C03



W8 - T...H-C03



W8 - T...H-D00



C8 - T...H-D00

ENCLOSURE CODE	CLASSIFICATION	ELECTRICAL COND. CONN.	MATERIAL	EARTH TERMINAL	TERM. BLOCK
C1	Weathertight (IP66) Intrinsically safe (with Option "I")	PG 13.5	Aluminium	Standard (Internal)	Standard
C2		M20 x 1.5			
C3		3/4" NPT (F)			
C4		1/2" NPT (F)			
C8		M20 x 1.5	SS 316 ¹⁾		
C9	3/4" NPT (F)				
W3	Explosion-proof ATEX & IECEx: Ex d IIC T6...T5 Ex tb IIIC T100 C IP66	3/4" NPT (F)	Aluminium	Standard In- & External	Standard
W8		M20 x 1.5			
W9		3/4" NPT (F)	SS 316 ¹⁾		

¹⁾ Includes SS 316 sensor body and adjusting nut.

2 RANGES

C3 - **T548H** - D00 - S0 - K1 - Y - X2

W8 - T...H - D00



W3 - T...H - D00



W3 - T...H - C03



C3 - T...H - D00



C8 - T...H - D00

RANGE CODE	ADJUSTABLE RANGE		MAX TYPICAL DEADBAND ³⁾		MAX. TEMPERATURE		PROOF TEMPERATURE		MAX. PROCESS PRESSURE	
	Min	Max	3)	°C	°C	°C	°C	°C	bar	
T 528 H	-40	+40	3	°C	+125	°C	+200	°C	175	bar
T 548 H	0	+95			+200	°C	+250	°C		
T 568 H ¹⁾	+60	+180			+300	°C	+350	°C		
T 588 H ²⁾	+160	+300	3.5	°C	+400	°C	+450	°C		

1) In case process temperature > 140°C, **Direct mount sensing bulb is not recommended.**

2) **Not in combination with Direct mount sensing bulb.**

3) For deadband calculation in combination with "SR"- and "SP"- micro, consult your BETA representative.

TEMPERATURE SWITCHES

3 SENSOR BULBS

C3 - T548H - **D00** - S0 - K1 - Y - X2

PROCESS CONNECTION	SENSOR CODE	TYPE OF TEMPERATURE SENSING BULB	
1/2" NPT (M)	D00	Direct mount. ¹⁾	128 mm length
	D02		225 mm length
	C02	Capillary mount.	2 m. capillary length
	C03		3 m capillary length
	C05		5 m. capillary length
	C10		10 m. capillary length
	CXX		Special capillary length ²⁾

Note: All SS 316 stainless steel sensor, capillary (SS 304 armored) and compression fitting.

¹⁾ Not in combination with range T588H (+160/+300 °C), not recommended with T568H in case of process temperature >140 °C.

²⁾ Length of capillary should be specified, consult your BETA Switch Representative. (Max.:15 mtr.)

*** Thermowells available, see page 30.*

4 DIAPHRAGM / O-RINGS

C3 - T548H - D00 - **S0** - K1 - Y - X2

All temperature switches have "S0" welded diaphragm.

5 SWITCHING ELEMENTS

C3 - T548H - D00 - S0 - **K1** - Y - X2

The standard Switching elements are: "K1" for C - and W - enclosures

Deadband Multiplier micro switch element similar as for pressure switch.

For other available switching elements and additional technical information see **5** on pages 11 and 12.

6 OPTIONS

C3 - T548H - D00 - S0 - K1 - **Y** - X2

OPTION CODE	DESCRIPTION
C	Cable gland (weather proof IP66, Exe, Exi or Exd in acc. with classification of enclosure).
I	Intrinsically safe application (EEx)i. Only on "C"-Series.
S	Stainless steel Tag key attached to enclosure. Tag has 2 lines (16 characters per line).
V	Fungicidal varnish coating (internal).
Y	Epoxy coating of enclosure and sensorbody (external).

Tag no. space on nameplates added free of charge

Standard nameplate **C-Series** : 2 lines with 16 characters or spaces + 1 line with 14 characters or spaces
W-Series : 1 line with 16 characters or spaces

6 SPECIALS

C3 - T548H - D00 - S0 - K1 - Y - **X2**

BETA can incorporate many specials to meet your requirements.

These special requirements are indicated by the letter "X" in the model code or at the end of the model number, followed by a figure showing the number of specials.

Example:

"X1" at the end of modelcode reference means **one** special.

"X2" at the end of modelcode reference means **two** specials have been incorporated.

Details of each special must always be specified completely on enquiries and orders.



BETA offers complete line of switches for (classified) hazardous area!

The "BETA Switch" is a safety instrument and adds an extra dimension to industrial safety because a wide selection of switches is available up to safety level Category 2 for hazardous areas (e.g. ATEX, IECEx)

Benefits

- Worldwide agency approvals.
- "User Friendly" Modifications – Standard features incorporated for your safety.
- Minimal amount of wetted parts - minimal maintenance needed.
- High overrange pressures allowed without setpoint shift or damage of functional parts
- Designed for reliability over the full life cycle time.

W-Series

ATEX: ITS 17ATEX 101854 X

Ex II 2 G Ex db IIC T6 . T5 Gb T6 $-60^{\circ}\text{C} \leq \text{Tamb} \leq +70^{\circ}\text{C}$ / T5 $-60^{\circ}\text{C} \leq \text{Tamb} \leq +80^{\circ}\text{C}$
Ex II 2 D Ex tb IIIC T 100 °C Db $-60^{\circ}\text{C} \leq \text{Tamb} \leq +80^{\circ}\text{C}$

IECEX IECEx ITS 17.0019 X

Ex db IIC T6 Gb - $60^{\circ}\text{C} \leq \text{Tamb} \leq +70^{\circ}\text{C}$
Ex db IIC T5 Gb - $60^{\circ}\text{C} \leq \text{Tamb} \leq +80^{\circ}\text{C}$
Ex tb IIIC T 100 °C Db $-60^{\circ}\text{C} \leq \text{Tamb} \leq +80^{\circ}\text{C}$

CSA: CERT.:1873316 acc. to Class 2258-02

Class I, Div. 1, Groups B, C, D T6/ -40 to $+70^{\circ}\text{C}$, T5/ -40 to $+80^{\circ}\text{C}$
Class II, III, Div.1, Groups E, F and G
Ex d IIC T6...T5
Enclosure Type 4X, IP66

FM: CERT.:3028962

Class I, Div. I, Groups A, B, C and D, T6 Ta = -40 to $+70^{\circ}\text{C}$, T5 T1 = -40 to $+80^{\circ}\text{C}$
Class I, Zone I, AEx d IIC, T6 Ta = $+70^{\circ}\text{C}$, T5 Ta = $+80^{\circ}\text{C}$

DIP, Class II/III, Div.1, Groups E, F and G, T6 Ta = $+70^{\circ}\text{C}$, T5 Ta = $+80^{\circ}\text{C}$

Enclosure Type 4X, IP66

C-Series Intrinsically safe

ATEX: CERT.: KIWA 15 ATEX 0023X

Ex II 1 G Ex ia IIC T4...T6 Ga or
Ex II 2 G Ex ib IIC T4...T6 Gb
Ex II 1 D Ex ia IIIC T 85°C Da or
EX II 2 D Ex ib IIIC T 85°C Db
Amb. Temp.: -60°C to $+80^{\circ}\text{C}$

CSA: CERT.:1891054 acc. to Class 2258-04

IS Class I, II, III, Div.1, Groups A, B, C, D, E, F and G
Ex ia IIC T6 T 85°C
Amb. Temp.: -40 to $+80^{\circ}\text{C}$
Enclosure Type 4X

IECEX: CERT.: KIWA 15.0011X

Type of protection: Exia
Ex ia IIC T6 Ga
Ex ia IIIC T 85°C Da

FM: Cert. No. 3031247

IS Class I, II and III, Div. 1, Groups A, B, C, D, E, F, G
Class I, Zone 0, AEx ia IICT6, $-40^{\circ}\text{C} < \text{Ta} < +80^{\circ}\text{C}$
Enclosure Type 4x

BETA SWITCHES FOR HAZARDOUS AREA

C-Series (Intrinsically safe) - ATEX, IECEx, CSA and FM approved.

(See also page 22)

BETA "C" - Series with option "I" for intrinsically safe systems.



"C" - Series



BETA has its "C"-Series switches with option "I" certified by KIWA acc. to NEN EN 60079-0 / EN 60079-11 for,

**II 1 G Ex ia IIC-T4...T6 Ga or
II 2 G Ex ib IIC-T4...T6 Gb or
II 1 D Ex ia IIIC T85°C Da or
II 2 D Ex ib IIIC T85°C Db**

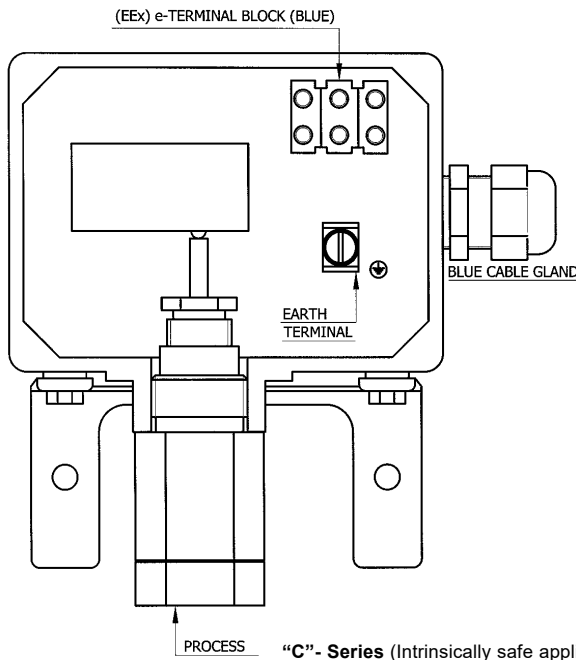

"C"- Series (Intrinsically safe application EEx i).

ATEX approved	: KIWA 15 ATEX 0023X	(-60 to +80°C)
IECEx approved	: KIWA 15.00IIX	(-60 to +80°C)
CSA approved	: Cert.No.: 1891054	(-40 to +80°C)
FM Approved	: Cert. No.: 3031247	(-40 to +80°C)

(For more information see also page 23)

This option includes all required installation materials including a blue colored EEx e approved terminal block and the (standard) earth terminal.

Option "I" in accordance with art. 9 of the ATEX Directive 94/9/EC (Ex ia/ib IIC) which are related to insulation, clearance, creepage distances and enclosure type whereby a max. peak voltage of 90 V or 3,3A is allowed.

Please note the following:

When a switch is ordered with cable gland (option "C") BETA will automatically install the EEx i blue cable gland (see drawing). Due to low current used in intrinsically safe systems we recommend the use of switching elements with gold contacts. (code "G1," "O1" or "Y1").

W-Series -ATEX, IECEx, CSA and FM approved.

The “W”-series is a worldwide best seller.



“W” - Series

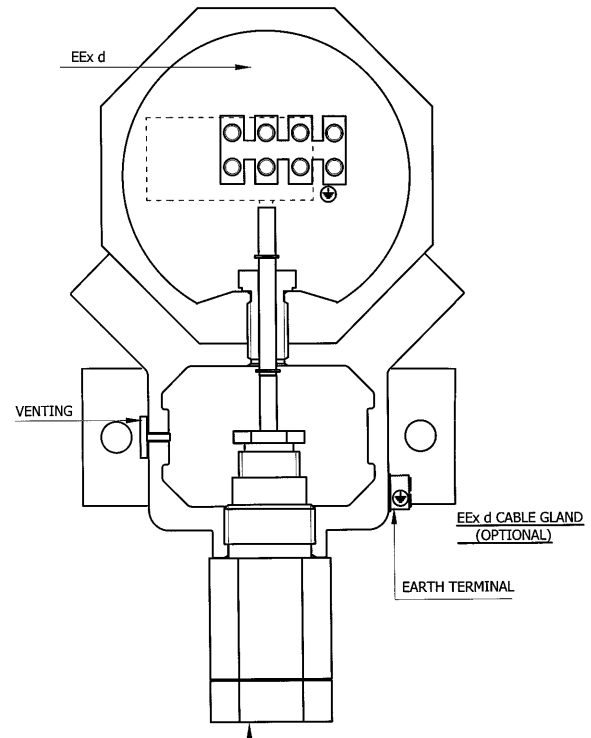

Separate adjustment compartment allows easy field calibration.

Due to the wide selection of materials and components parts, virtually all applications can be covered.

ATEX approved: ITS 17ATEX 101854 X

- * For Gas : Ex II 2 G Ex db IIC T6...T5 Gb
- * For Dust : Ex II 2 D Ex tb IIIC T100°C Db

IECEx IECEx ITS 17.0019 X

- Ex db IIC T6...T5 Gb
- Ex tb IIIC T 100 °C Db

(For more information see also page 23)

- Aluminium with Extremely rugged powder coated enclosure which is suitable for tough offshore applications. (1000 hrs. Salt spray test acc. to DIN 50021, IEC 60068-2-11 or ASTM B117-90) or 316 SS enclosure.
- Separate adjustment compartment.
- Available as Pressure-, Hydraulic-, Vacuum-, Differential pressure- and Temperature switch.
- All ranges available.
- Highest overrange protection.
- Excellent for field mounting (2" Pipe SS mounting bracket available), see page 31.
- Epoxy coating optional.
- Also available in SS316.

BETA PRESSURE & TEMP. SWITCH - CERTIFICATIONS

SIL 2 certification:

In order to state SIL2 compliance based on the standard IEC 61508, please consider the following conditions:

Always read the BETA installation, Operation, Safety Manual before installation, setting and testing is started Installation, setting and testing may only be performed by qualified personnel using calibrated equipment and based on the approved SIL I.O.S Manual Instruction.

BETA is not responsible for changes in settings out of BETA production

EXPLOSION-PROOF CERTIFICATIONS:

Besides the already mentioned explosion-proof certificates, also available are:

Russian market (Commuty Russia, Kazachstan, Belurus)

CU TR 012-2011 Ex Safety Directive

C-series 0Ex ia IIC T6 ... T4 Ga / 1Ex ib IIC T6 ... T4 Gb
Ex ia IIIC T85°C Da / Ex ib IIIC T85°C Db

W-series 1Ex d IIC T6 ... T5 Gb
Ex tb IIIC T100°C Db X



Korean Market

Korea Industrial Technology Institute

Certificate for explosion safety



Japan

JIS



China

Nepsi Cert No GYJ17 1038X
Ex d IIC T5/T6 Gb



OTHER CERTIFICATION:

Europe

2014/68/EU Pressure Equipment Directive (PED)

C-and W-series Type approval module B

QA system Module D CE 0035



Russian Market (Commuty Russia, Kazachstan, Belurus)

CU TR 004-2011 Low Voltage Directive

Cert Nr. 0705132



Marine Approval

B-, C- and W-series type approval

DNV rules for classification:

DNV-GL-CG-U339

Pressure switches : TAA 0000 2VB

Temperature switches : TAA 0000 2VC



More certificates/ reports are available. Please consult your BETA Switch Representative.

"C"- Series: Pressure & Vacuum "P...H"

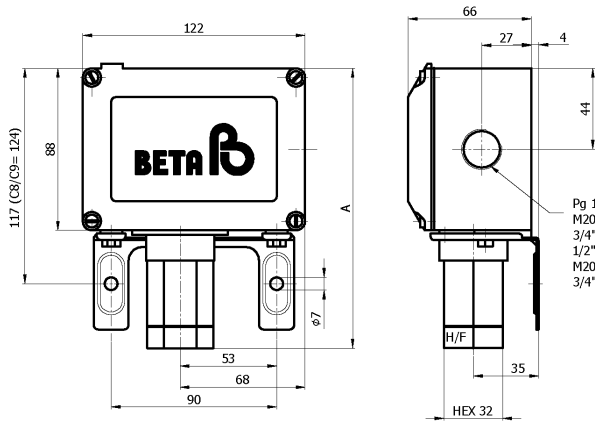

"W."- Series: Pressure & Vacuum "P...H"

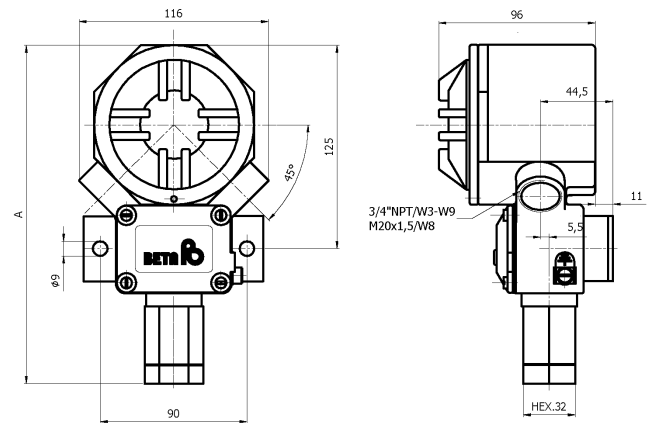

"C"- Series: Pressure & Vacuum "P...M"

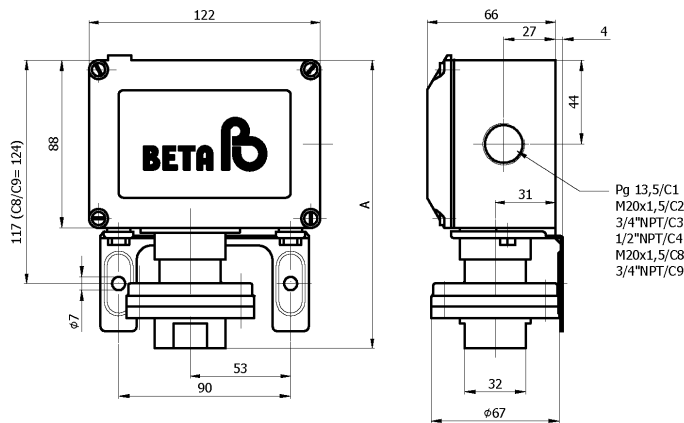

"W."- Series: Pressure & Vacuum "P...M"

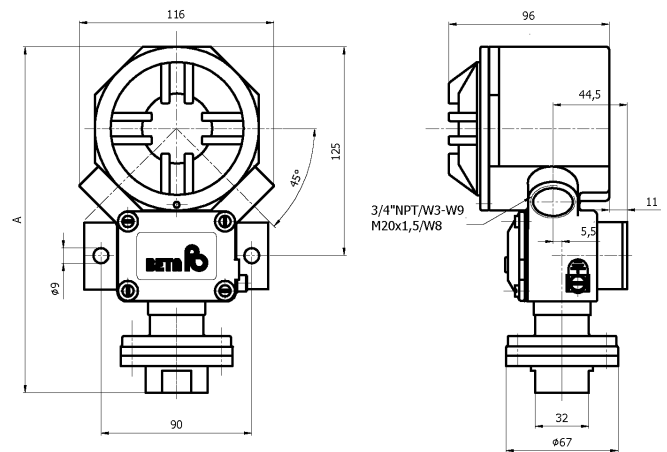

"C"- Series: Pressure & Vacuum "P...L"

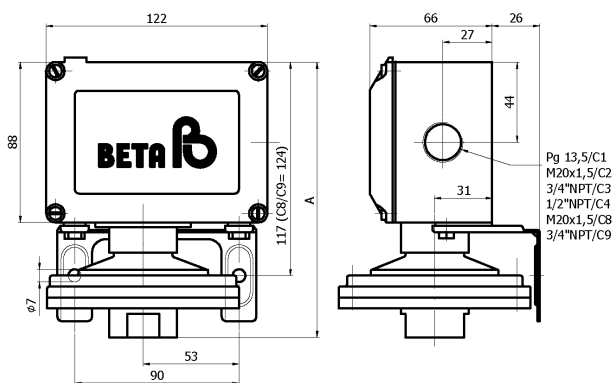

"W."- Series: Pressure & Vacuum "P...L"

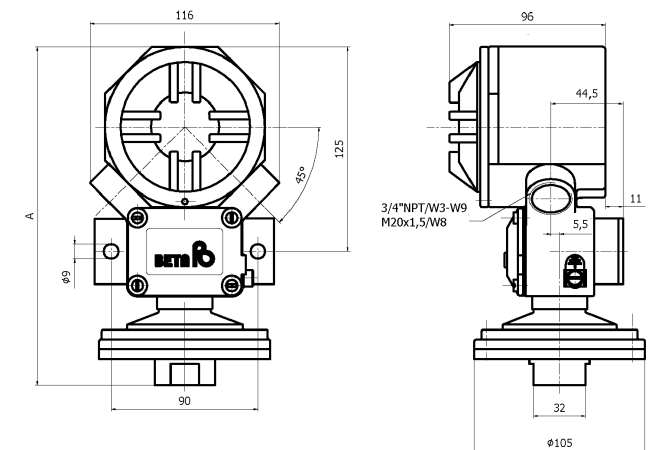

** For specific details about the dimension "A" please consult your BETA representative.

DIMENSIONS

“C”- Series: Differential “D...L”

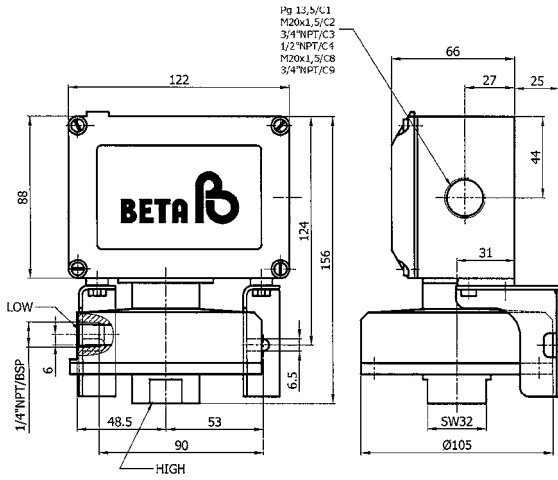

“W”- Series: Differential “D...L”

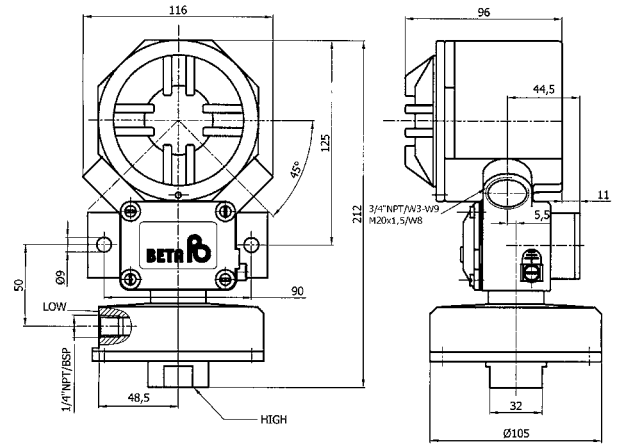

“C”- Series: Differential “D...M”

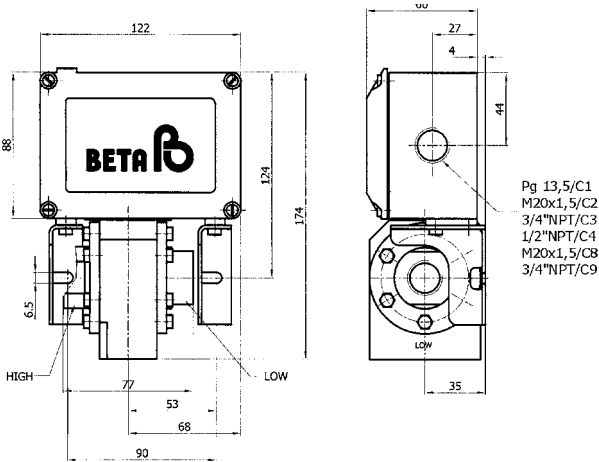

“W”- Series: Differential “D...M”

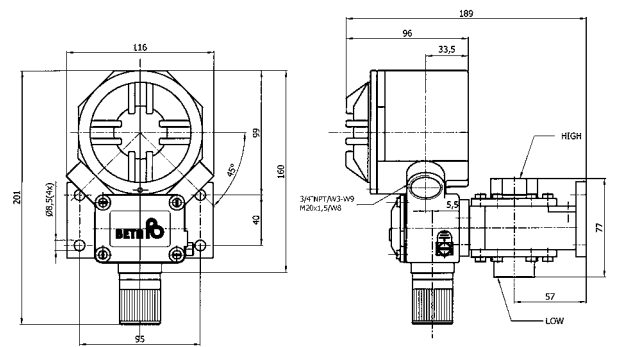

“C”- Series: Differential “D...H”

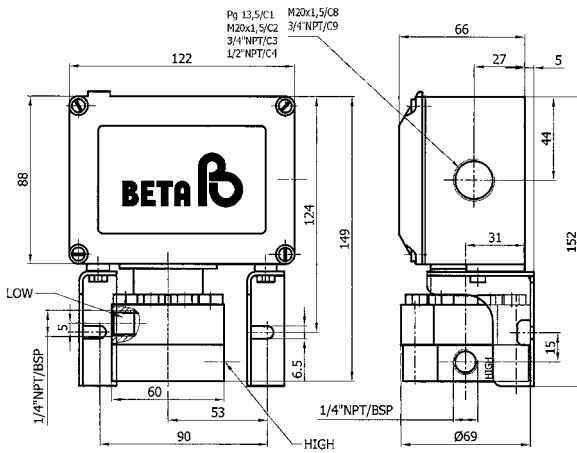

“W”- Series: Differential “D...H”

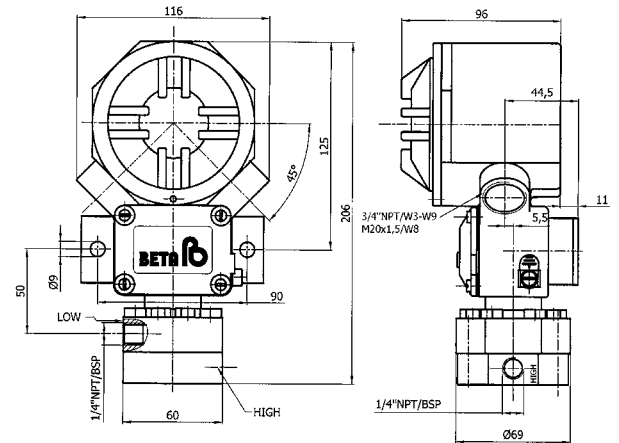

“C”- Series: Bi-directional Differential “D...D”

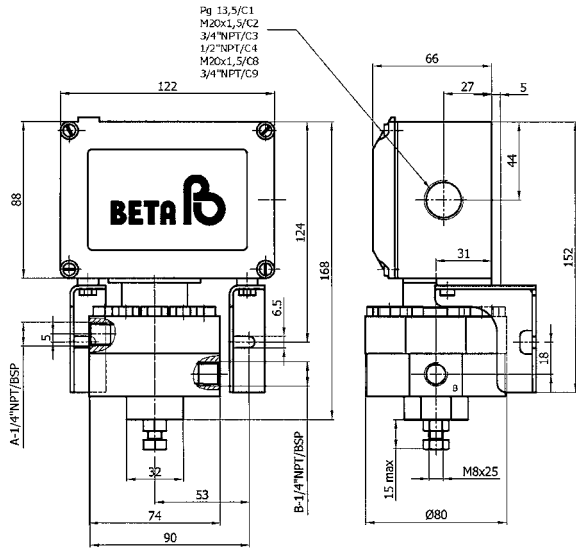

“W.”- Series: Bi-directional Differential “D...D”

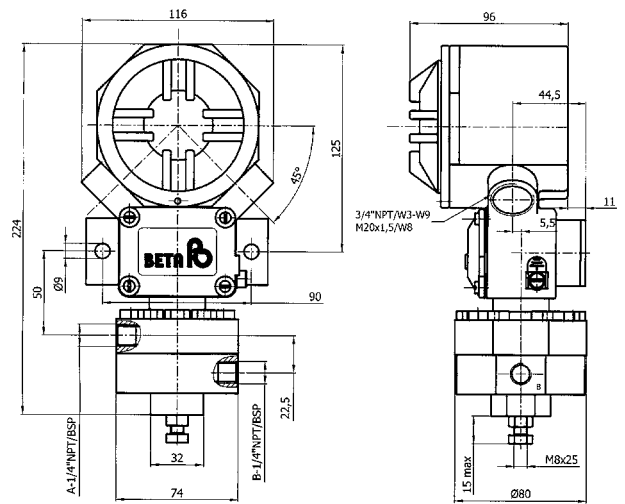

“C”- Series: Temperature “T..H - D”

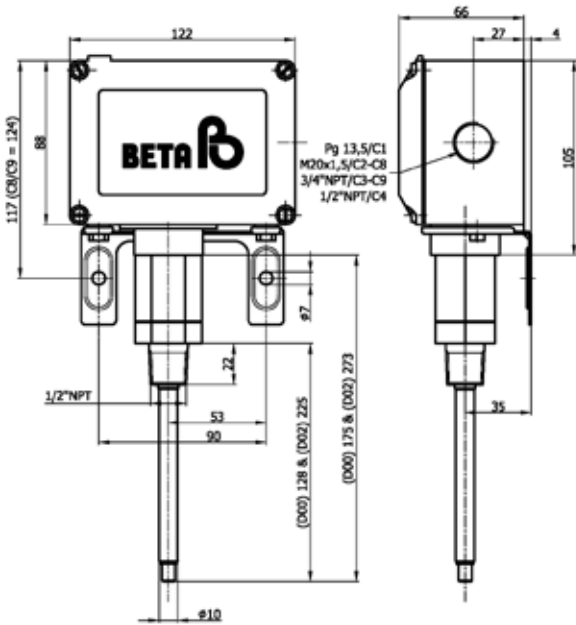

“W.”- Series: Temperature “T..H - D”

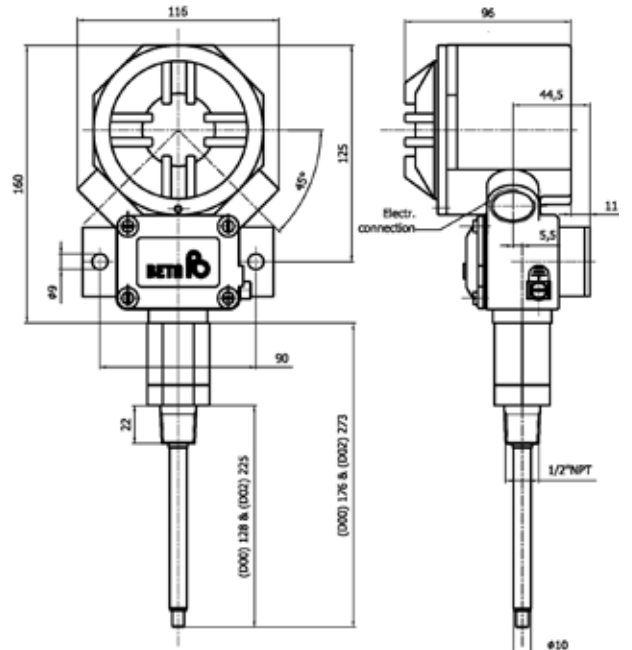

DIMENSIONS

"C"- Series: Temperature "T..H-C"

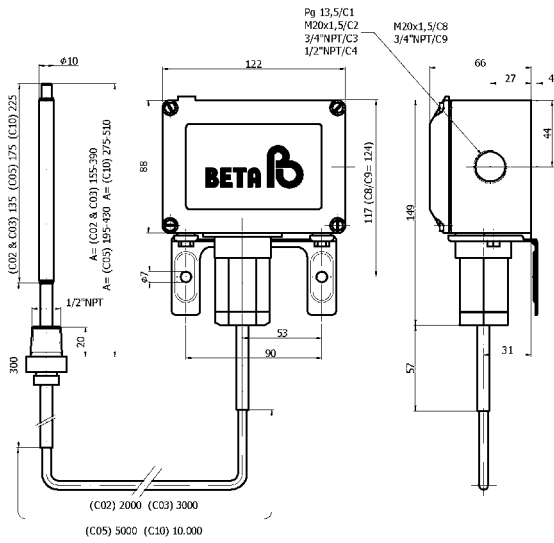

"W."- Series: Temperature "T..H-C"

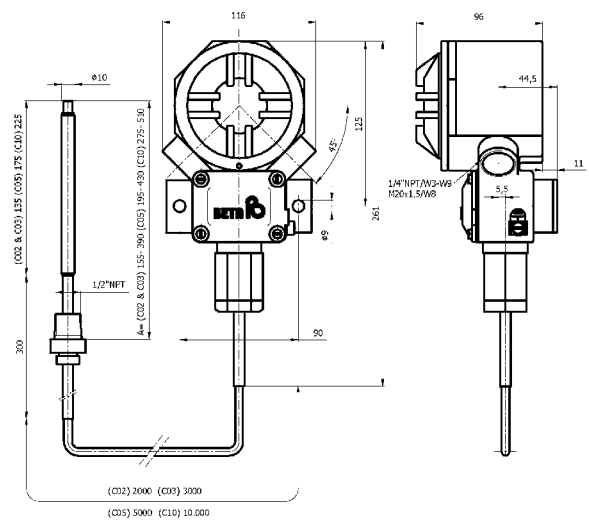

ACCESSORIES

Thermowell (SS 316)

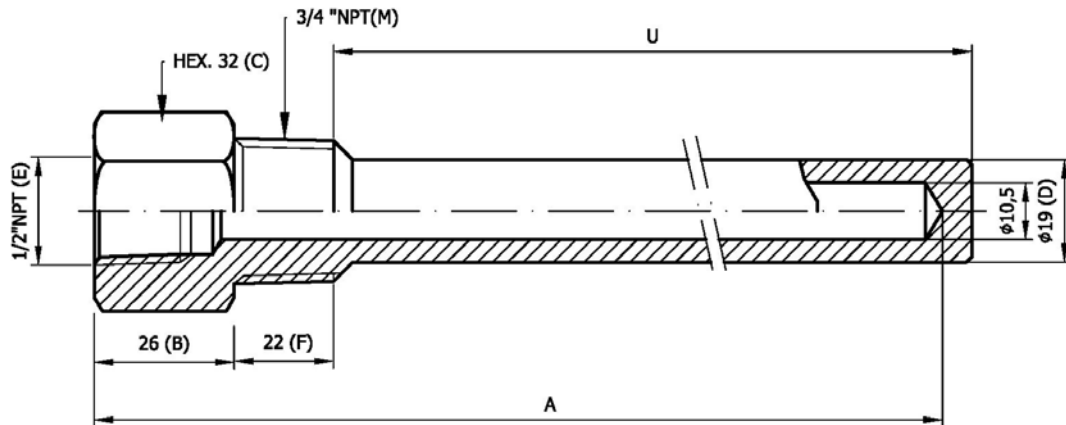

Standard BETA Thermowell

CODE	INSERTION LENGTH U (MM)	INSERTION ELEMENT LENGTH A (MM)	FIT TO BETA TEMPERATURE SENSING BULB
TW 11	115	155	D00, C02, C03
TW 15	155	195	D02, C02, C03, C05
TW 19	190	228	C02, C03, C05

NOTES:

1. BETA Thermowells to be ordered as a separate item.
2. Special Thermowell possible. Consult your BETA Switch Representative.

Contents :

W3 - enclosure

- 2 x Bracket +
- 2 x bolts M8 x 100 mm + nut

or

C - series

- 2 x bolts M6 x 100 mm + washer + nut

(Size: +/- 1,5 mm tolerance) / Material SS 304

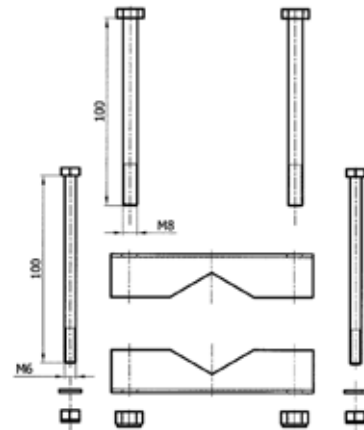

Disclaimer :

This pipe mount bracket is solely intended for use in combination with BETA Pressure & Temperature Switches.

Foundation vibrations, as well as process vibrations, can disturb the proper functioning of the mounted instrument, the use of this bracket does not prevent or diminishes such occurrence.

2" Pipemount Set (SS 304) Configuration Examples

"C."- Series Enclosure on 2" Pipe

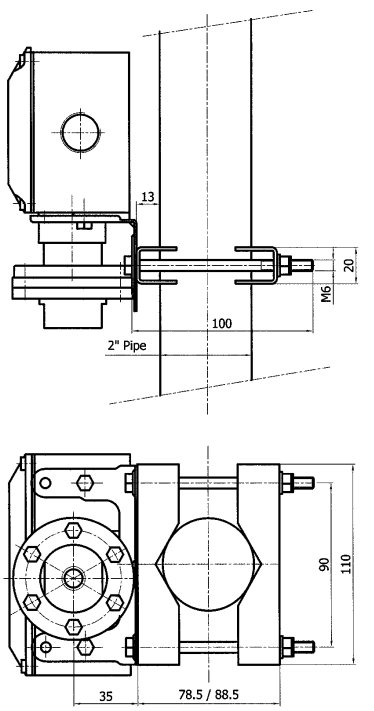

"W."- Series Enclosure on 2" Pipe

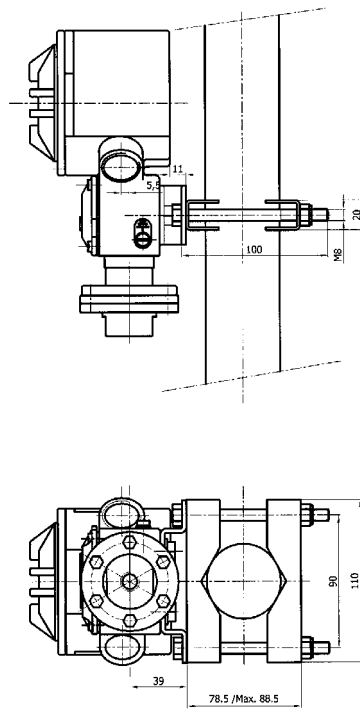

"W."- Series Enclosure "D...M" on 2" Pipe

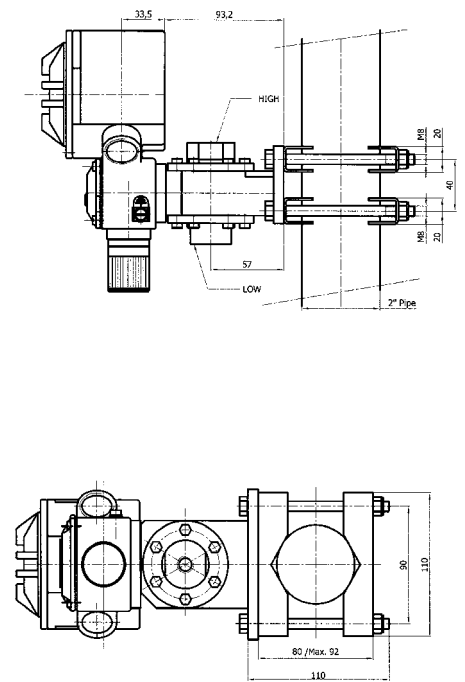

Dimensions given here are for 1/4" and 1/2" (F) process connections: For "H"-sensor with 1/2" (F) add 4 mm on "A" dimension. Sizes in mm, tolerances ± 1,5 mm.

Pressure and Temperature Switches

C & W - series switches



Contact:

BETA Pressure & Temperature switches
are designed & manufactured in The Netherlands

OFFICE:

Verrijn Stuartlaan 22
2288 EL Rijswijk
The Netherlands

E-MAIL:
2sales@beta-b.nl

TELEPHONE:
+ 31 (0)70 - 319 9700

INTERNET:
www.beta-b.nl

Note:

We reserve the right to make technical changes or modify the contents of this document without prior notice. With regard to purchase orders, the agreed particulars shall prevail. BETA B.V. does not accept any responsibility whatsoever for potential errors or possible lack of information in this document.

We reserve all rights in this document and in the subject matter and illustrations contained therein. Any reproduction, disclosure to third parties or utilization of its contents – in whole or in parts – is prohibited without prior written consent of BETA B.V.

Copyright© 2021 - BETA B.V.
All rights reserved