



Contents

1	Introduction.....	3
1.1	General Information for the users	3
1.2	Manufacturer Warranty	3
1.3	Explosion Proof Warning	4
2	Product Description	5
2.1	General	5
2.2	Main Features and Functions	5
2.3	Label Description	5
2.4	Product Code	6
2.5	Product Specification	7
2.6	Certifications	8
2.7	Parts and Assembly	9
2.8	Product Dimension	10
3	Installation.....	12
3.1	Safety	12
3.2	Tools for installation	12
3.3	Linear position transmitter installation	12
3.3.1	Safety	13
3.3.2	Installation Steps	13
3.4	Rotary position transmitter Installation	19
4	Connections - Power.....	21
4.1	Safety	21
4.2	Terminal Overview	22
5	Calibration and PCB Operation.....	23
5.1	Function of Switch and Buttons on PCB.....	23
5.1.1	Slide Switch	23
5.1.2	Buttons	24
5.2	Modes using LCD	25
5.2.1	Position Mode (POSITION)	25
5.2.2	Manual Calibration Mode (HAND CAL)	26
5.2.3	View Mode (VIEW).....	28
5.2.4	Error Code	29
6	LCD Operating Flow Chart	31
7	Troubleshooting and repair	32

1 Introduction

1.1 General Information for the users

Thank you for purchasing Rotork YTC Limited products. Each product has been fully inspected after its production to offer you the highest quality and reliable performance. Please read the product manual carefully prior to installing and commissioning the product.

- Installation, commissioning, and maintenance of the product may only be performed by trained specialist personnel who have been authorized by the plant operator accordingly.
- The manual should be provided to the end-user.
- The manual can be altered or revised without any prior notice. Any changes in product's specification, design, and/or any components may not be printed immediately but until the following revision of the manual.
- The manual should not be duplicated or reproduced for any purpose without prior approval from Rotork YTC Limited, Gimpo-si, South Korea.
- In case of any other problems that are not stated in this manual, please make immediate contact to Rotork YTC Limited.
- Position Transmitter is an accessory of the control valve, so please make sure to read the applicable instruction manual of the control valve prior to installation and operation.

1.2 Manufacturer Warranty

- For the safety, it is important to follow the instructions in the manual. Manufacturer will not be responsible for any damages caused by user's negligence.
- Any modifications or repairs to the product may only be performed if expressed in this manual. Injuries and physical damages caused by customer's modifying or repairing the product without a prior consultation with Rotork YTC Limited will not be compensated. If any alterations or modifications are necessary, please contact Rotork YTC Limited directly.
- The warranty period of the product is (18) months from the date of shipment unless stated otherwise. Date of shipment can be checked by providing the LOT NO. or SERIAL NO. to us.
- Manufacturer warranty will not cover products that have been subjected to abuse, accidents, alterations, modifications, tampering, negligence, misuse, faulty installation, lack of reasonable care, repair or service in any way that is not contemplated in the documentation for the product, or if the model or serial number has been altered, tampered with, defaced or removed; damages that occurs in shipment, due to act of God, failure due to power surge, or cosmetic damage. Improper or incorrectly performed maintenance will void this limited warranty.
- For detailed warranty information, please contact the corresponding local Rotork YTC Limited office or main office in South Korea.

1.3 Explosion Proof Warning

Please ensure the unit is being used and installed in conformity with local, regional, and national explosion proof within the explosion proof certified environment.



- SPTM-6V / 65V is Explosion proof construction for internal pressure.
For detail information, refer to “2.6 Certifications”
- Explosion proof type of cables and gaskets should be used, when explosion gases are present at the installation site. Please make sure that the sealing has been done completely.
- Keep cover tight while circuits are alive.
- Power should be turned off completely when opening product’s cover. When opening the cover, ensure that there is no power remaining in any electrical parts nearby.
- This product has 2 ports for power connection. Please make sure that Blind plug is tightened to the port when any port is not being used.
- Ring terminal with surface area of more than 1.25 mm² with M4 spring washer should be used to connect the power.
- For external ground terminal, ring terminal with surface area of more than 5.5 mm² should be used.
- There is risk of explosion due to electro-static charge. Static electricity charge may develop when cleaning the product with a dry cloth. It is imperative to avoid static electricity charge in the hazardous environment. If cleaning the surface of the product is needed, must use wet clothes.

2 Product Description

2.1 General

SPTM-6V / 65V series is 2 wire type transmitter with in-built micro-processor which transmits 4 ~ 20 mA DC signal according to changes in valve or damper position.

2.2 Main Features and Functions

- Designed to be flameproof enclosure.
- A wide range of uses with IP67 protection grade.
- LCD displays current output signal.
- Very easy and simple calibration.
- Polyester powder coating of SPTM-6V resists the corrosion process. (except SPTM-65V)

2.3 Label Description

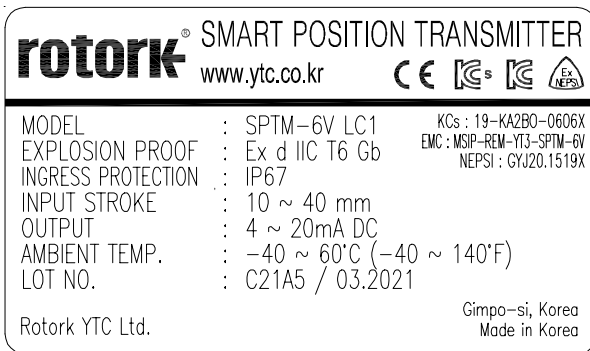

Fig. L-1: SPTM-6V (KCs, NEPSI)

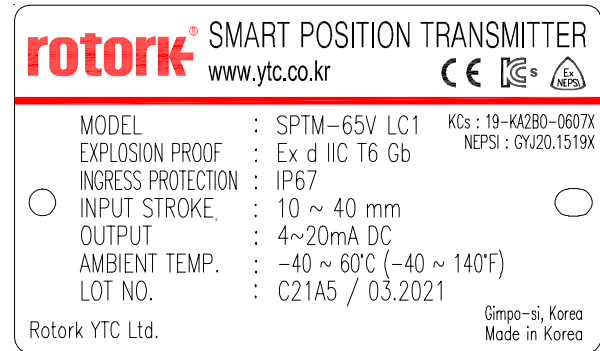

Fig. L-2: SPTM-65V (KCs, NEPSI)

- MODEL : Indicates the model number and additional symbols.
- EXPLOSION PROOF : Indicates certified explosion proof grade.
- INGRESS PROTECTION : Indicates enclosure protection grade.
- INPUT STROKE : Indicates input rotation angle.
- OUTPUT : Indicates output signal range.
- AMBIENT TEMPERATURE : Indicates allowed explosion proof ambient temperature range.
- LOT NO. : Indicates unique lot number.
- MONTH.YEAR : Indicates manufactured month and year.



Fig. L-3: SPTM-6V (EAC)



Fig. L-4: SPTM-65V (EAC)

2.4 Product Code

SPTM-6V / 65V **1** **2** **3**

1 Motion Type	L : Linear
	R : Rotary
2 Explosion Proof	C : Ex d IIC T6 (KCs)
	¹⁾ Z : Ex d IIC T6 Gb (NEPSI)
	E : 1Ex d IIC T6 Gb (EAC)
3 Lever Type	Linear
	1 : 10 ~ 40 mm
	2 : 20 ~ 70 mm
	3 : 50 ~ 100 mm
	4 : 100 ~ 150 mm
Rotary	1 : Standard Lever type
	2 : NAMUR type

¹⁾ The threads of the conduit entry are 1/2 NPT for NEPSI, and G 1/2 for others.

2.5 Product Specification

Model		SPTM-6V	SPTM-65V
Connection Type		2 Wire	
Input Stroke	Linear	10 ~ 150 mm	
	Rotary	55 ~ 100°	
Output Signal		4 ~ 20 mA DC	
External Load Resistance		$R_{ext} \leq (V_s - 9) / 20 \text{ mA}$, 750 ohms @ $V_s = 24 \text{ V}$	
Supply Voltage		9 ~ 28 V DC	
Conduit Entry		G 1/2 (except NEPSI) or 1/2 NPT(only NEPSI)	
Explosion Proof		Flameproof enclosure. Refer to "2.6 Certifications"	
Ingress Protection		IP 67	
Ambient Temperature	Operating	-40 ~ 85 °C (-40 ~ 185 °F)	
	Explosion Proof	KCs, NEPSI : -40 ~ 60 °C (-40 ~ 140 °F) EAC : -60 ~ 60 °C (-76 ~ 140 °F)	
Linearity		± 1 % F.S.	
Hysteresis		± 0.2 % F.S.	
Sensitivity		± 0.2 % F.S.	
Housing Material		Aluminum	Stainless steel 316
Painting		Polyester Powder Coating	-
Weight		1.3 kg (2.91 lb)	2.8 kg (6.17 lb)



Tested under ambient temperature of 20 °C, absolute pressure of 760 mmHg, and humidity of 65 %.

Please contact Rotork YTC Limited for detailed testing specification.

2.6 Certifications

※ All certifications below are posted on Rotork YTC Limited homepage(www.ytc.co.kr).

➤ **KCs (Korea)**

Type : Explosion proof construction for internal pressure

Rating : Ex d IIC T6 IP67

Certification No. : 19-KA2BO-0606X (SPTM-6V)

19-KA2BO-0606X (SPTM-65V)

Ambient temperature : -40 ~ +60°C

➤ **NEPSI (China)**

Type : Explosion proof construction for internal pressure

Rating : Ex d IIC T6 Gb

Certification No. : GYJ20.1519X

Ambient temperature : -40 ~ +60°C

➤ **EAC (TRCU, Russia + Kazakhstan + Belarus)**

Type : Explosion proof construction for internal pressure

Rating : 1Ex d IIC T6 Gb IP67

Certification No. : RU C-KR.AM02.B.00044/19

Ambient temperature : -60 ~ +60°C

➤ **Electromagnetic Compatibility (EMC)**

- EMC directive 2014/30/EC from April 2016

- EC Directive for CE conformity marking

2.7 Parts and Assembly

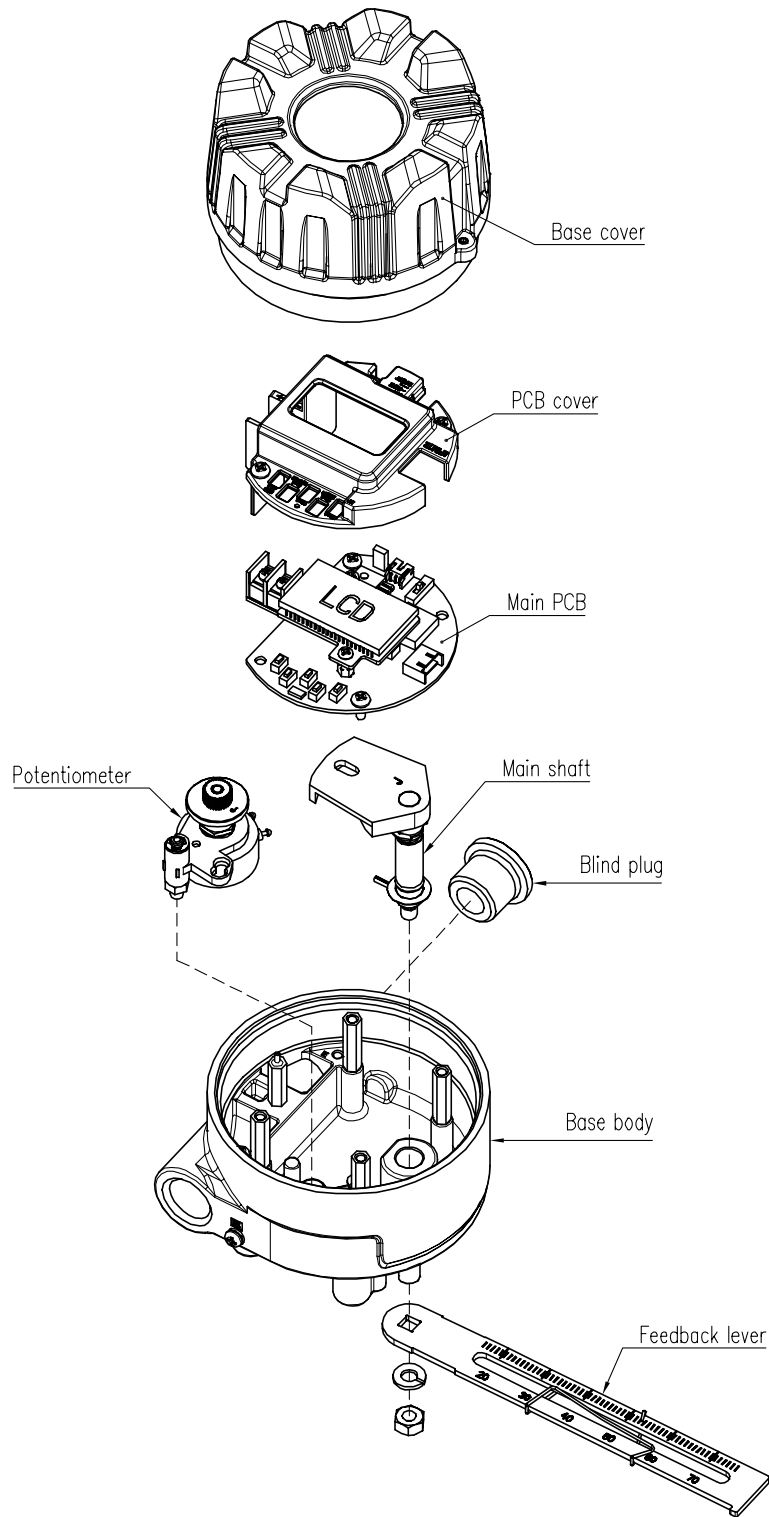

Fig. 2-1: Exploded view

2.8 Product Dimension

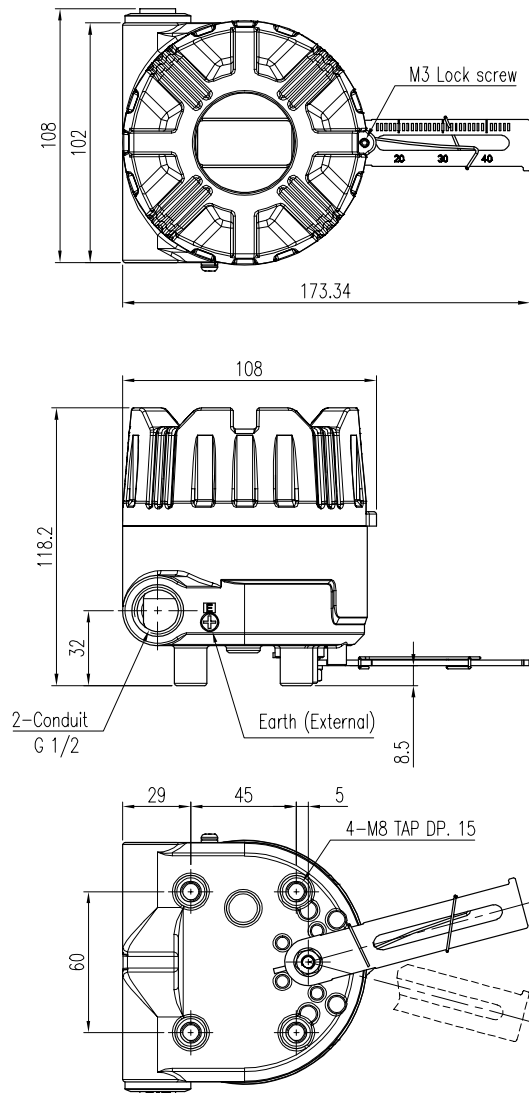

Fig. 2-2: SPTM-6VL / 65VL (Linear Type)

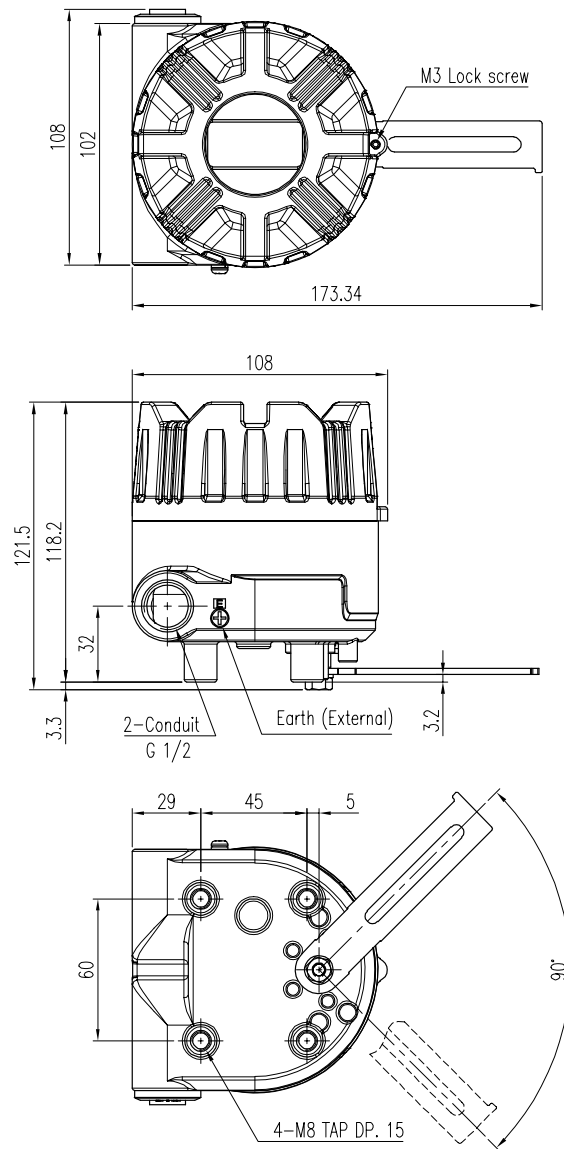

Fig. 2-3: SPTM-6VR / 65VR (Rotary Lever Type)

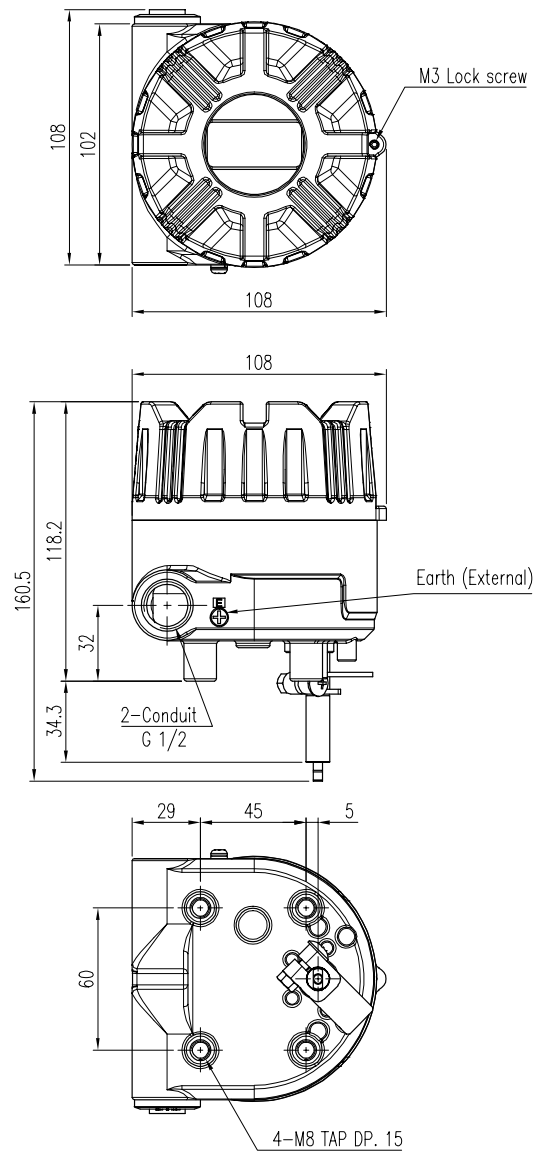

Fig. 2-4: SPTM-6VR / 65VR (Rotary NAMUR Type)

3 Installation

3.1 Safety

When installing the unit, please ensure to read and follow safety instructions.



- Check the unit's specification and ensure to use as specified.
- Follow other explosion proof procedures and safety precautions.
- In case of hazardous area, please ensure there is no explosion gas in the atmosphere.
- Any input or supply pressures to valve, actuator, and / or to other related devices must be turned off.
- Use bypass valve or other supportive equipment to avoid entire system "shut down".

3.2 Tools for installation

- Hex key set for hex socket cap bolts
- (+) & (-) Screw drivers
- Spanners for hexagonal-head bolts

3.3 Linear position transmitter installation

Linear position transmitter should be installed on linear motion valves such as globe or gate type which uses spring return type diaphragm or piston actuators.

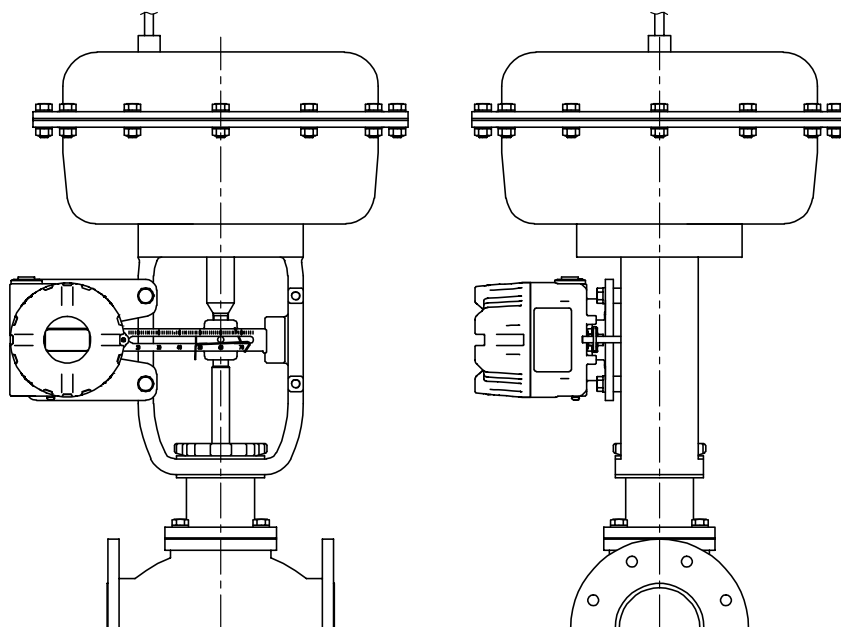

Fig. 3-1: SPTM-6VL / 65VL installation example
(Attached on Left yoke of actuator)

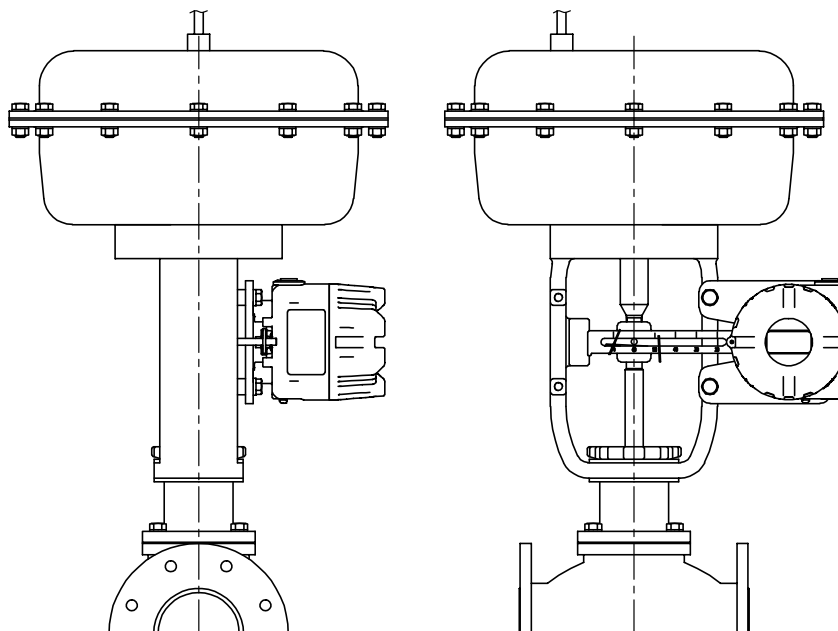

Fig. 3-2: Attached on Right yoke of actuator

Before proceeding with the installation, ensure following components are available.

- Position transmitter
- Feedback lever and lever spring
- M6 nut and spring washer (fastening feedback lever to a main shaft)
- Bracket, bolts and washers – not supplied with the position transmitter
- Connection bar – not supplied with the position transmitter

3.3.1 Safety

Proper bracket must be made in order to adapt the position transmitter on the actuator yoke.

Please consider following important points when a bracket is being designed.

- Position transmitter's feedback lever must be vertical to the valve stem at 50 % of the valve stroke.
- The connection bar of the actuator clamp for the feedback lever should be installed in such a way that the valve stroke length coincides with the corresponding figure in "mm" marked on the feedback lever. Improper setting may cause poor linearity



3.3.2 Installation Steps

- 1) Assemble the position transmitter with the bracket made in previous step by fastening the bolts. The bolt size is M8 x 1.25P.

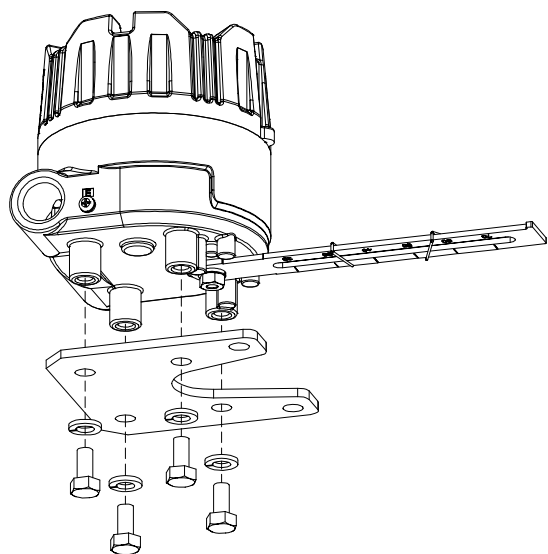

Fig. 3-3: Attaching SPTM-6V/65V to bracket

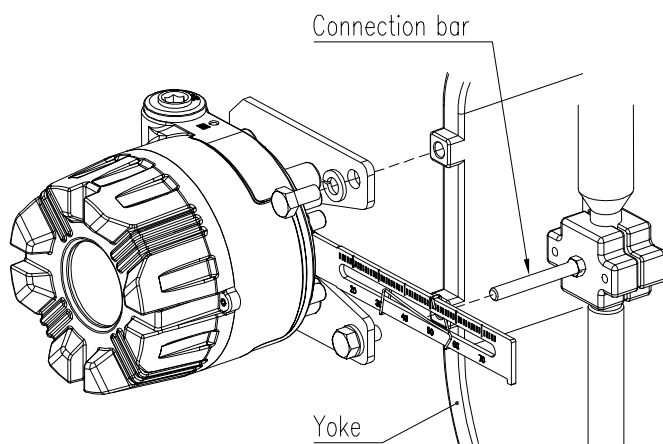

Fig. 3-4: Attaching the bracket to actuator yoke

- 2) Attach the position transmitter with the bracket to the actuator yoke.
– **DO NOT TIGHTEN THE BRACKET COMPLETELY.**
- 3) Connect connection bar to the actuator clamp. The hole gap on the feedback lever is 6.5 mm so the connection bar's outer diameter should be less than 6 mm.
- 4) Connect an air-filter regulator to the actuator temporarily. Supply enough air pressure to the actuator in order to position the valve stroke at 50 % of the total stroke.

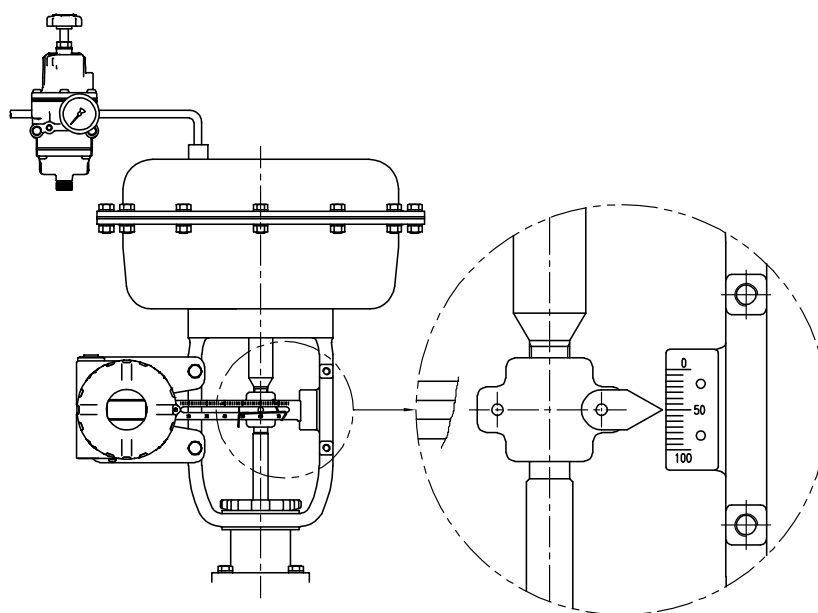

Fig. 3-5: Proper way to locate feedback lever by connecting pneumatic pressure to actuator to position the valve at 50 %

- 5) Insert the connection bar between the feedback lever and lever spring. The connection bar must be located upward from the lever spring as shown the below left figure. If it is located downward from the lever spring as shown the below right figure, the connection bar or the lever spring will be worn out quickly because of excessive strong tension.

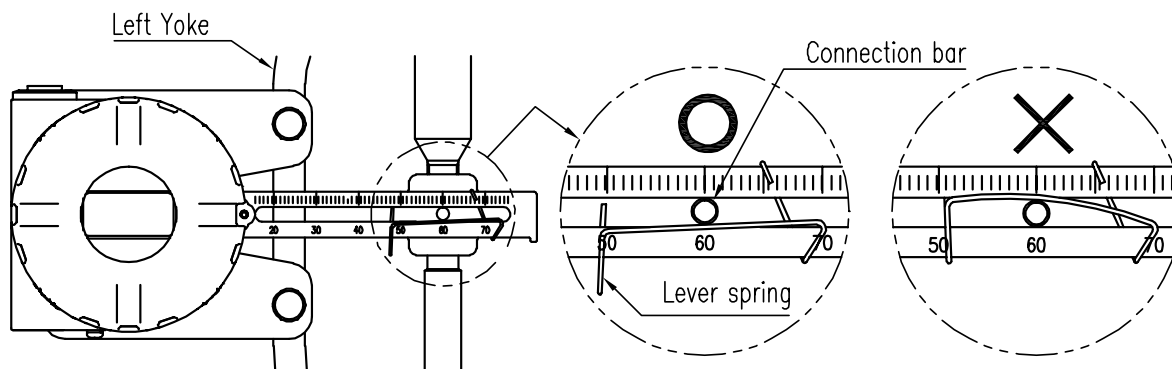

Fig. 3-6: Proper way to insert connection bar between feedback lever and lever spring
(When the position transmitter is attached to Left Yoke.)

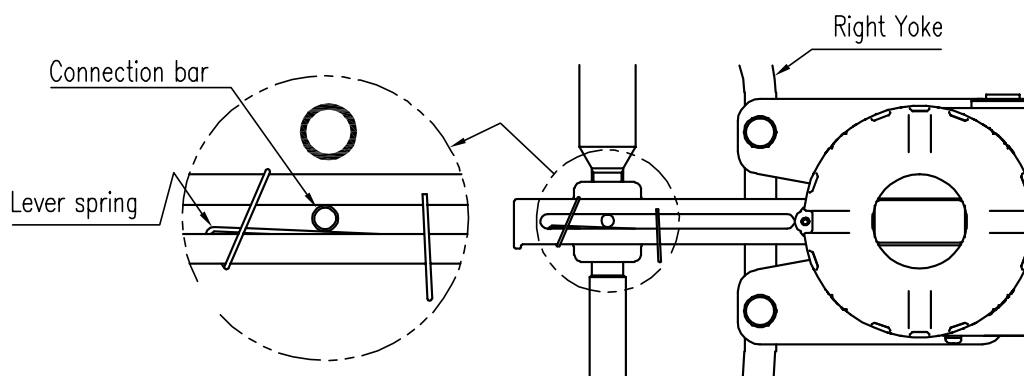

Fig. 3-7: When the position transmitter is attached to Right Yoke.

- 6) Check if feedback lever is vertical to the valve stem at 50 % of the valve stroke. If it is not vertical, adjust the bracket or the connection bar to make vertical. Improper installation may cause poor linearity.

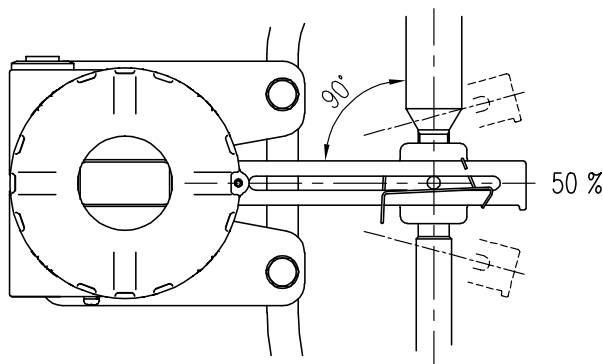

Fig. 3-8: Forming 90° angle between Feedback lever and Stem at 50 % stroke of the valves.

- 7) Check the valve stroke. The stroke numbers are engraved on the feedback lever of the position transmitter. Position the connection bar at the number on the feedback lever which corresponds with the desired valve stroke. To adjust, move the bracket, the connection bar or both.

※ The effective linear lever angle is 30 degree.

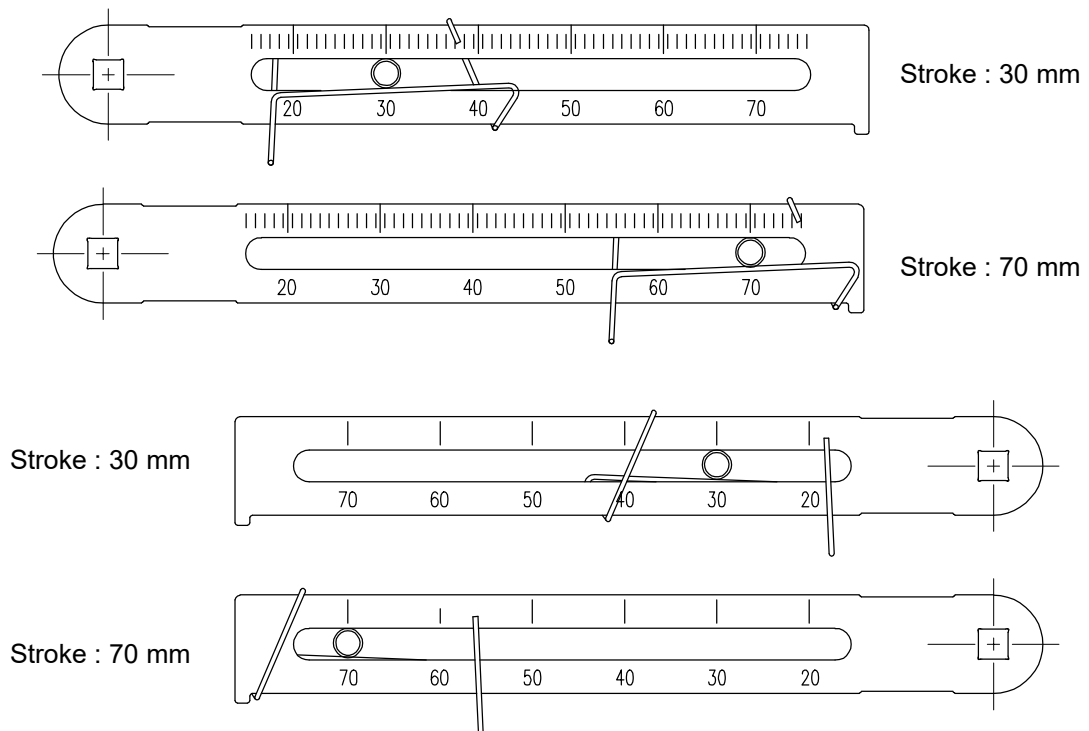

Fig. 3-9: Feedback lever and location of the connection bar



- 8) After installing the linear position transmitter, operate the valve from 0 % to 100 % stroke. On both 0 % and 100 %, the linear lever should not touch the linear lever stopper, which is located on the backside of the linear position transmitter. If the linear lever touches the linear lever stopper, the linear position transmitter should be installed further away from center of the actuator.

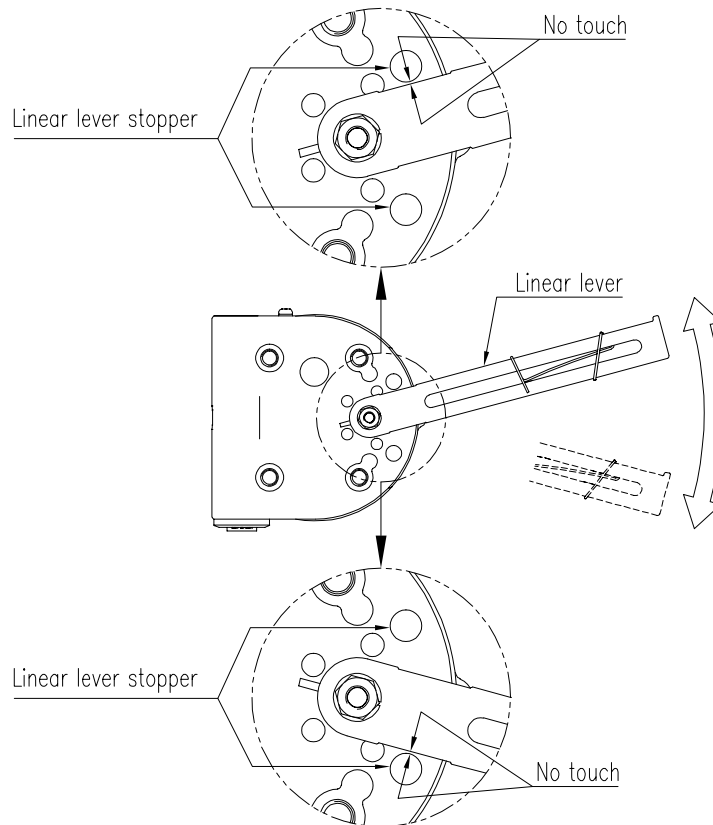

Fig. 3-10: Linear lever should not touch linear lever stopper on 0 % ~ 100 % valve stroke.

- 9) After the installation, tighten all of the bolts and nuts on the bracket, yoke and the connection bar.

- 10) The factory default of the direction of LCD is to have viewing direction when the position transmitter is installed to the left yoke of the actuator. If the position transmitter is installed to the right yoke of the actuator, the LCD will read upside down and the LCD can be rotated 180° as shown in the picture below. Also Lever need to be rotated.

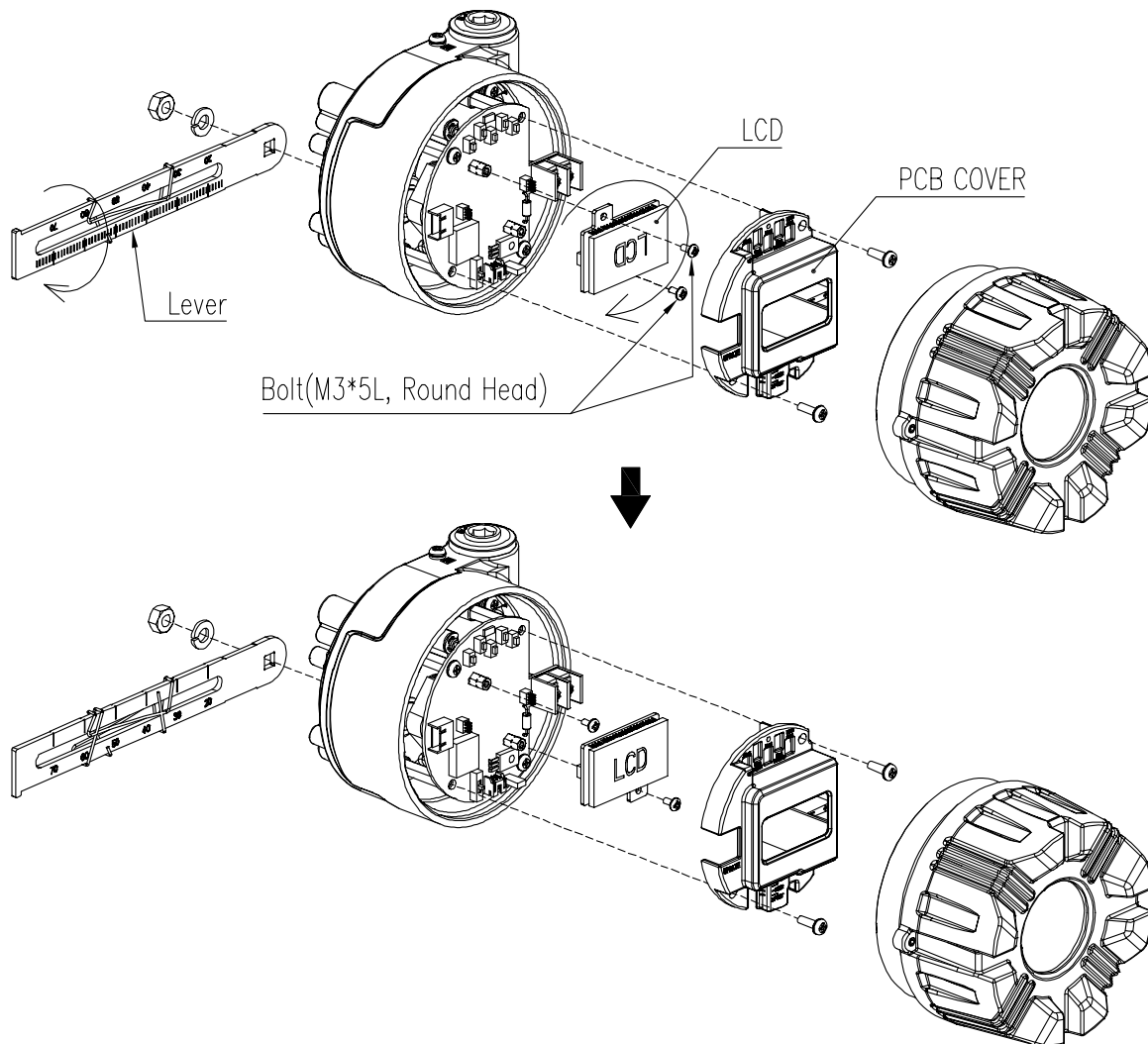

Fig. 3-11: Rotating LCD

3.4 Rotary position transmitter Installation

Rotary position transmitter should be installed on rotary motion valve such as ball or butterfly type which uses rack and pinion, scotch yoke or other type of actuators which its stem rotates 90 degrees.

- There are two types of feedback – Rotary lever and Namur shaft.
- Please refer to below a figure to make a proper bracket for a position transmitter of rotary lever type.

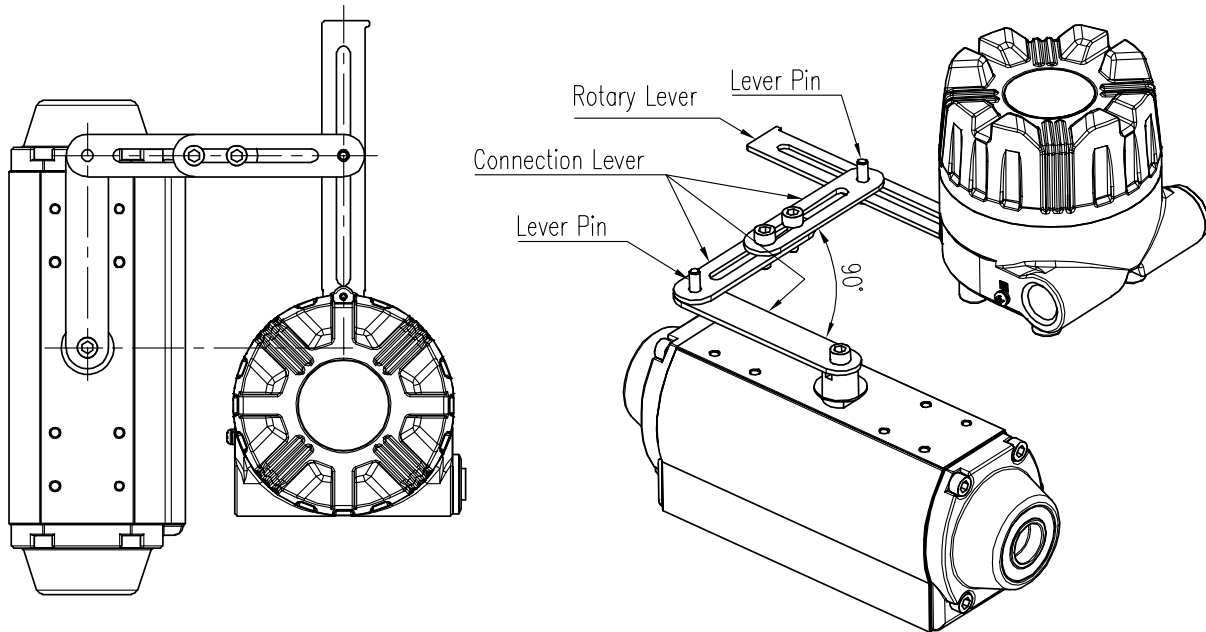

Fig. 3-12: Lever type SPTM-6VR / 65VR installation example

- After installing the rotary position transmitter, operate the valve from 0 % to 100 % stroke.



On both 0 % and 100 %, the rotary lever should not touch the rotary lever stopper, which is located on the backside of the rotary position transmitter. If the rotary lever touches the rotary lever stopper, the rotary position transmitter should be installed further away from center of the actuator.

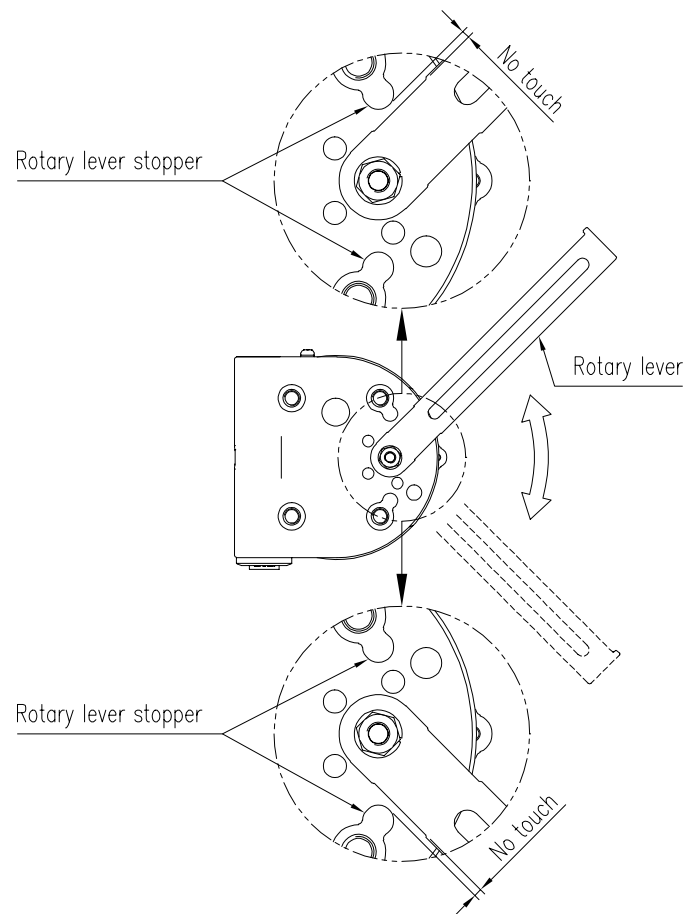

Fig. 3-13: Rotary lever should not touch rotary lever stopper on 0 % ~ 100 % valve stroke.

4 Connections - Power

4.1 Safety

When installing a unit, please ensure to read and follow safety instructions.

- There are two conduit entries on the product.
- When installing in hazardous and explosive gas area, conduit tube or pressure-proof packing union must be used. The compound charging box should be the flameproof type and must be sealed completely.
- Before connecting terminal, ensure that the power is off completely. **Do not open the cover when the power is still alive.**
- Please use ring terminal to protect against vibration or any other external impact.
- Position transmitter should be grounded. There are four grounding points at outside and inside of position transmitter.
- Please use twisted cable with conductor section are 1.25 mm² and that is suitable for 600 V (complying with the conductor table of NEC Article 310). The outer diameter of the cable should be between 6.35 ~ 10 mm. Use shield wire to protect against electro-magnetic field and noise.
- Please do not install the cable near high noise equipment, such as high-capacity transformer or motor. Please use shielded cable if necessary.

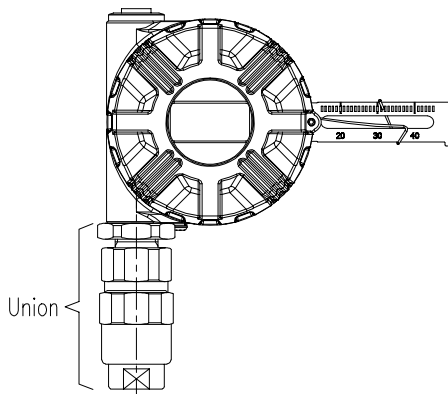

Fig. 4-1: Pressure-proof packing union

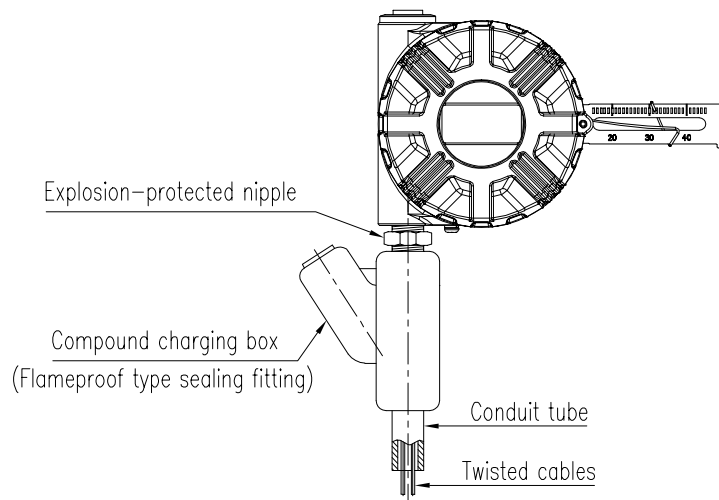

Fig. 4-2: Flame proof type compound charge box

4.2 Terminal Overview

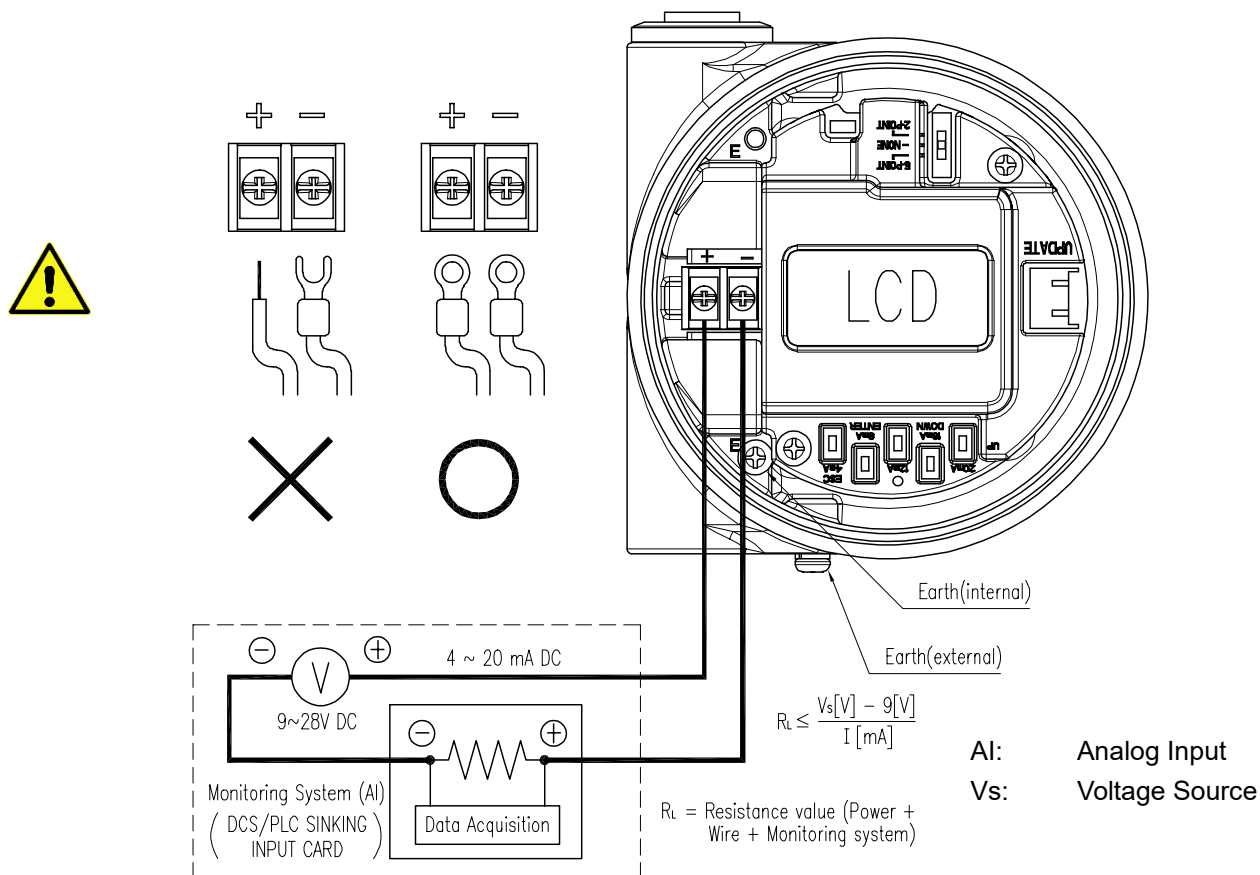

Fig. 4-3: Terminal Overview

- Open terminal cover by removing stopper bolt using 3 mm wrench.
- Insert cables into the conduit entry and secure them with (+) and (-) terminals on the plate. Make sure to tighten bolts with 1.5 N • m (15 kgf • cm) torque. Please check the polarity of the terminals.
- There are two terminals inside and two outside for grounding.
- Ground resistance must be below 100 ohm.

5 Calibration and PCB Operation

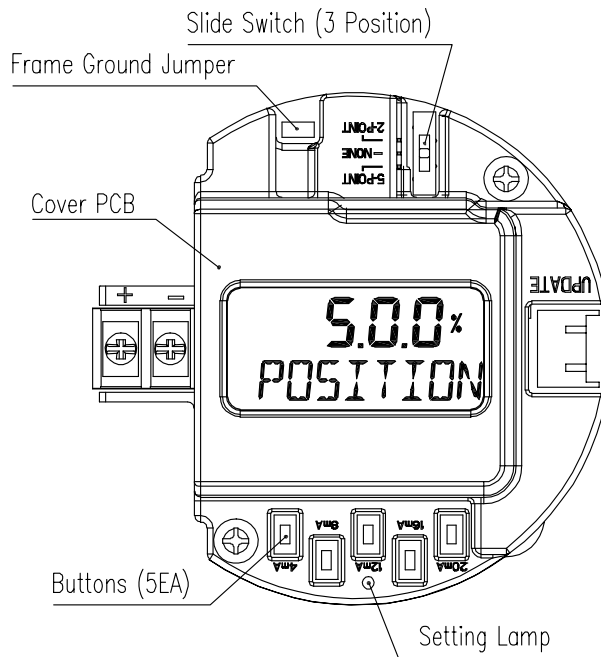

Fig. 5-1: PCB Layout

5.1 Function of Switch and Buttons on PCB

5.1.1 Slide Switch

Smart Position Transmitter can be calibrated by 2 or 5 points setting. The slide switch has 2 or 3 positions as below.

1) 2 Point setting position:

By setting only zero and end points (0 % and 100 % of valve stroke), the outputs can be set accordingly. When zero and end points are set, 25 %, 50 %, 75 % points are automatically calibrated.

2) 5 Point setting position:

By setting 5 points (0 %, 25 %, 50 %, 75 %, and 100 %), the outputs can be set accordingly. Different from 2 point setting, 5 point setting allows the end user to set 0 %, 25 %, 50 %, 75 %, 100 % to their desired positions. All 5 points should be set when using this position.

3) NONE position:

If the slide switch is in this position, calibration setting cannot be adjusted.

This position is used to prevent the set-values from changing when the user mistakenly press the buttons after calibration has been completed. Only calibration setting is restricted from this position and all other adjustments can be done.

5.1.2 Buttons

Smart Position Transmitter has 5ea buttons

1) 4mA (UP) button:

The button is used when setting 0 % position of full stroke during calibration. Position the valve at 0 %, press and hold the button for 2 seconds and the lamp will flash twice quickly. "4mA SET" will be displayed and the lamp will flash three times quickly again to confirm that the new setting has been saved. UP button could also be used when increasing the parameter values in the menu.

2) 8mA (DOWN) button :

The button is used when setting 25 % position of full stroke during calibration. Position the valve at 25 %, press and hold the button for 2 seconds and the lamp will flash twice quickly. "8mA SET" will be displayed and the lamp will flash three times quickly again to confirm that the new setting has been saved. DOWN button could also be used when decreasing the parameter values in the menu.

3) 12mA button:

The button is used when setting 50 % position. Position the valve at 50 %, press and hold the button for 2 seconds and the lamp will flash twice quickly. "12mA SET" will be displayed and the lamp will flash three times quickly again to confirm that the new setting has been saved.

4) 16mA (ESC) button:

The button is used when setting 75 % position of full stroke during calibration. Position the valve at 75 %, press and hold the button for 2 seconds and the lamp will flash twice quickly. "16mA SET" will be displayed and the lamp will flash three times quickly again to confirm that the new setting has been saved. ESC button could also be used to "Return" to previous menu.

5) 20mA (ENTER) button:

The button is used when setting 100 % position of full stroke during calibration. Position the valve at 100 %, press and hold the button for 2 seconds and the lamp will flash twice quickly. "20mA SET" will be displayed and the lamp will flash three times quickly again to confirm that the new setting has been saved. ENTER button could also be used to enter the menu or when saving the parameter values.

5.2 Modes using LCD

- This function is only supported to smart position transmitter with LCD.
- This function will apply equally regardless of the slide switch position.

There are four types of display message in modes using LCD.

- 1) Position Mode (POSITION)
- 2) Manual Calibration Mode (HAND CAL)
- 3) View Mode (VIEW)
- 4) Error Code

5.2.1 Position Mode (POSITION)

After power connection to the position transmitter, Position Mode will be appeared on the LCD screen.

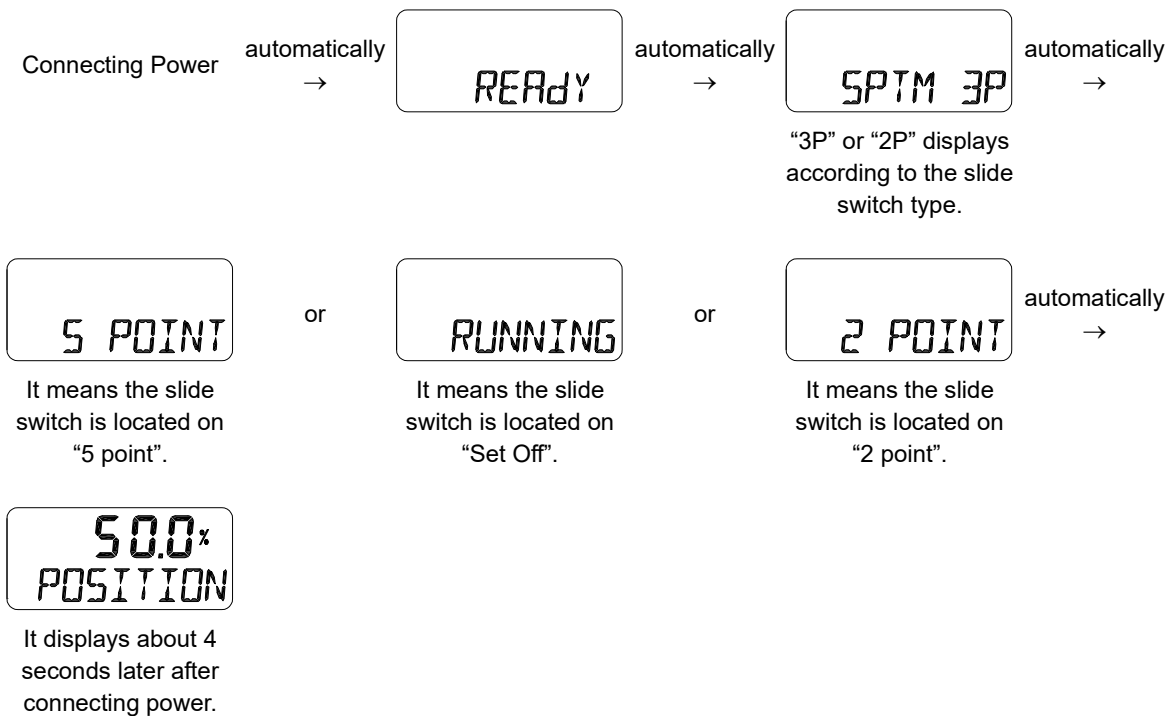

“POSITION” indicates the position of the current valve stroke.

Position mode can be showed in two different symbols, % or mA. To convert, press both 4mA and 20mA buttons at the same time for 2 seconds and release the buttons when the lamp flashes once. 2 seconds after, the lamp will flash twice quickly and the display will convert from % to mA or mA to %. (It is the same regardless of slide switch position)

1) Changing Travel Display from % to mA

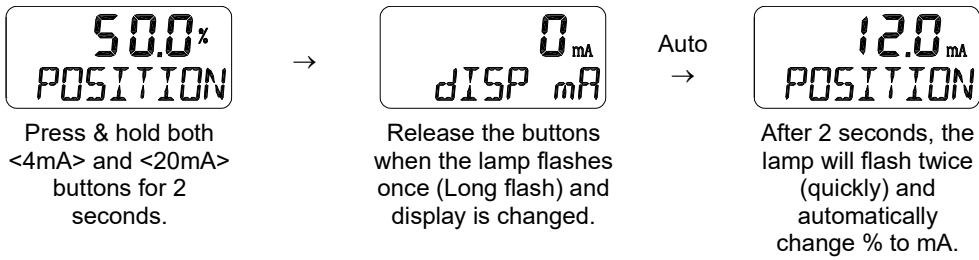

2) Changing Travel Display from mA to %

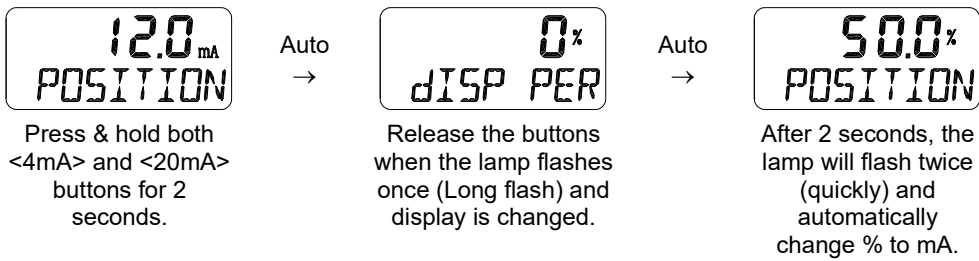

5.2.2 Manual Calibration Mode (HAND CAL)

This mode is used to change the TR ZERO or TR END values of the transmitter. TR ZERO adjusts the zero point of the transmitter (4mA feedback), and TR END adjusts the end point of the transmitter (20mA feedback). Use this function when setting the feedback output signal different from the actual valve's travel. For example, when changing 4 mA = 0 % default setting to 5 mA = 0 %. TR ZERO and TR END values can be changed regardless of the valve's current position. A device such as ammeter is required to check the feedback signal and adjustment can be done by connecting the wires as shown in below diagram.

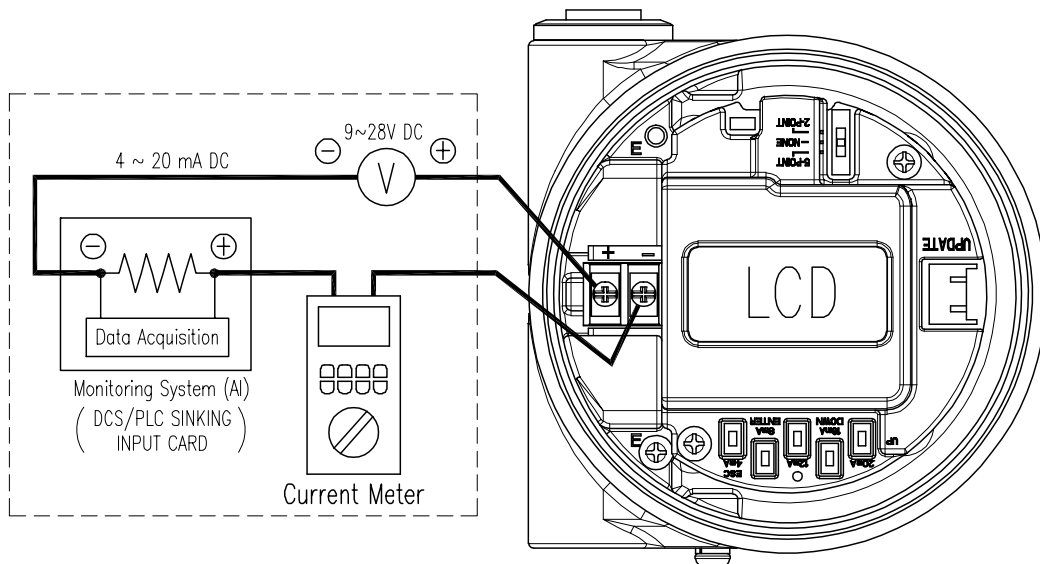
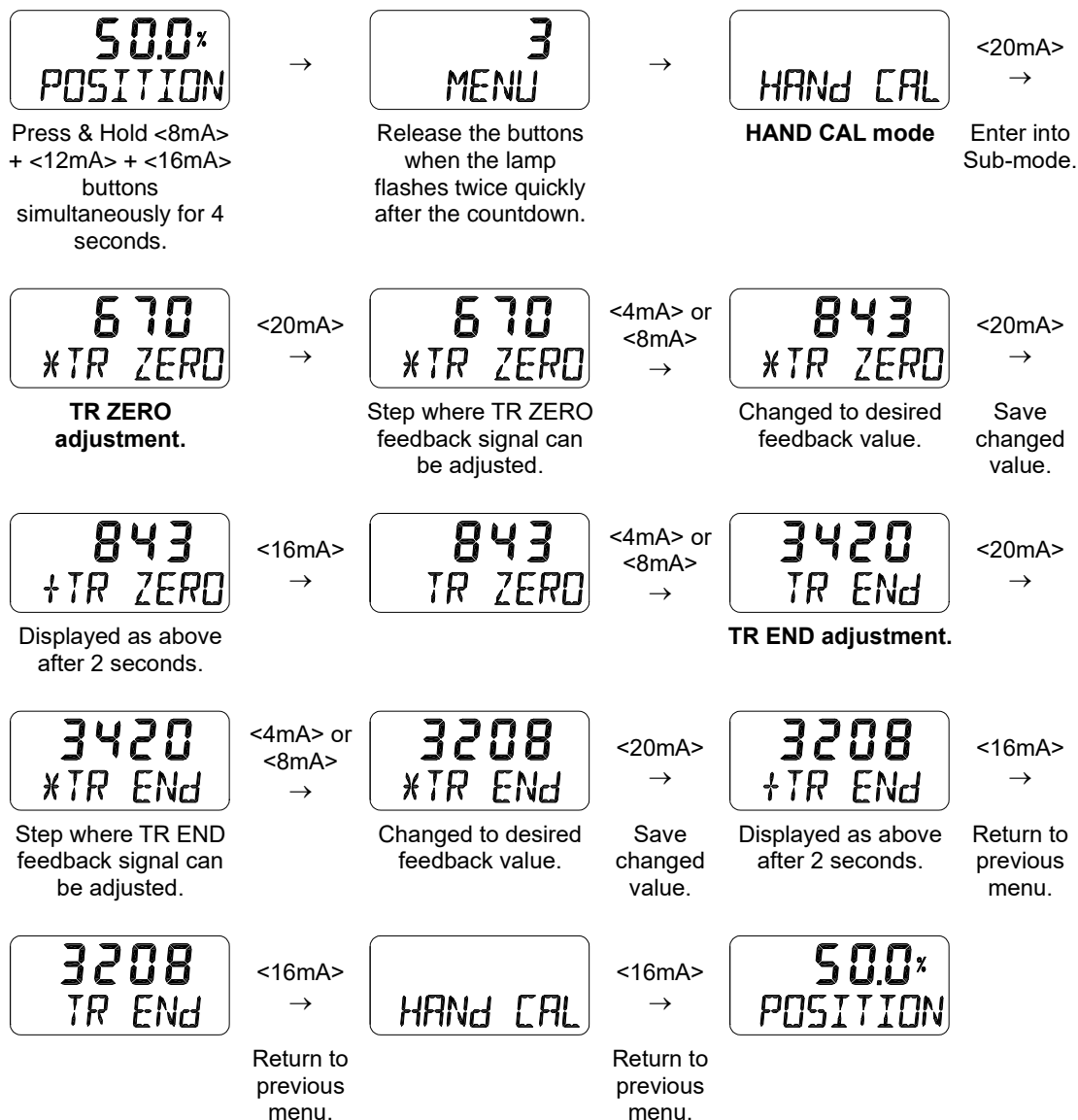

Fig. 5-2: TR ZERO and TR END Adjustment

※ The slide switch must be positioned at 2-point or 5-point to use this mode.



5.2.3 View Mode (VIEW)

Various information of the positioner is provided and can be adjusted from View Mode.

Below are sub-modes of View Mode.

- 1) View Mode Normal (VM NOR) or View Mode Reverse (VM REV) or View Mode Digit(VM diZ) :
The valve stroke % on LCD can be changed to normal or reverse direction.
Under VM NOR setting, 4 mA output will show as 0 % and 20 mA will show as 100 % on LCD.
Under VM REV setting, 4 mA will show 100 % and 20 mA will show as 0 % on LCD.
Under VM diZ setting, raw data is displayed.

- 2) Main firmware version (VERSION)

Refer to “5.2.5 error code” for types of errors in detail.

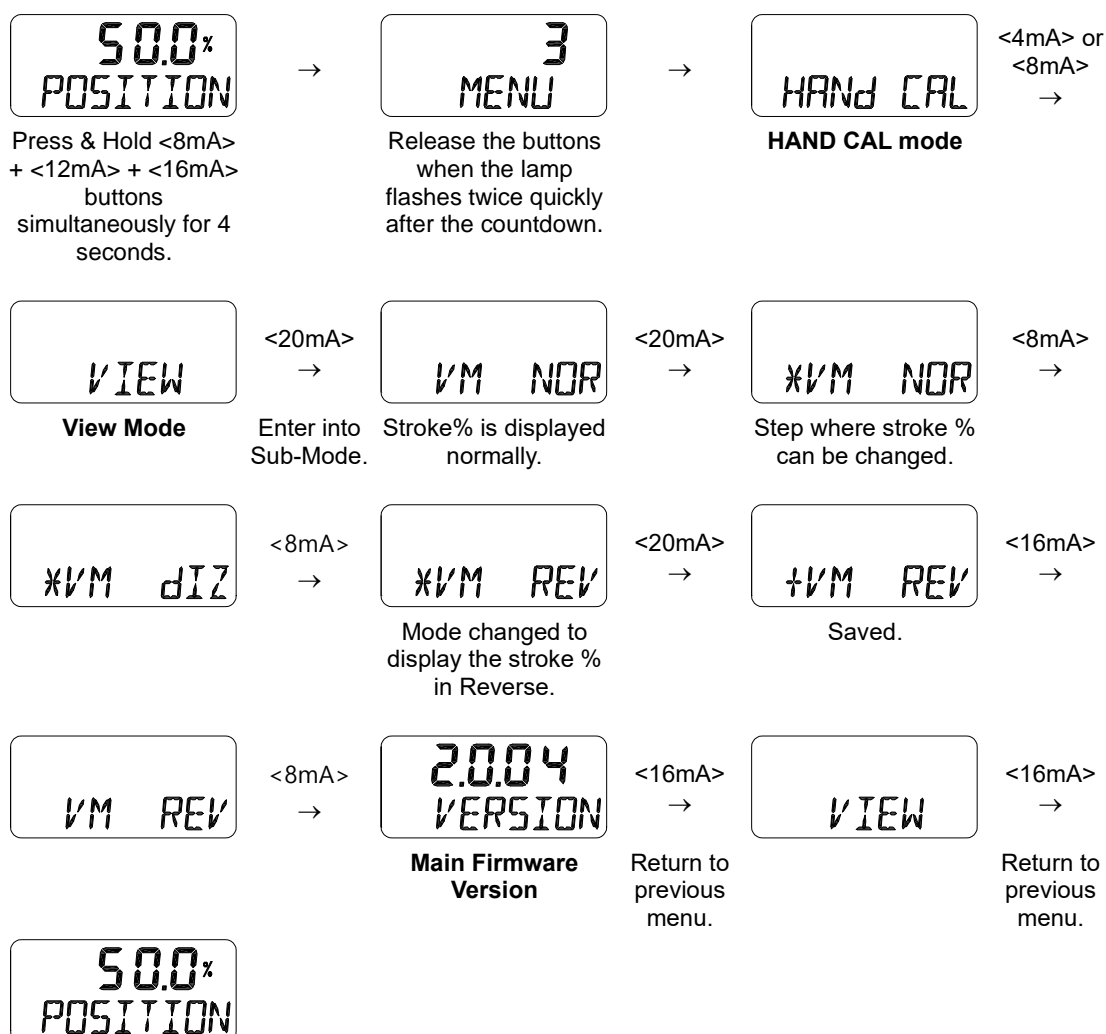

5.2.4 Error Code

Error is either displayed on the LCD (product with LCD) or indicated by flashing LED pattern (product without LCD) if there is an error occurs during operation.

1) Error Code Display – LCD Type

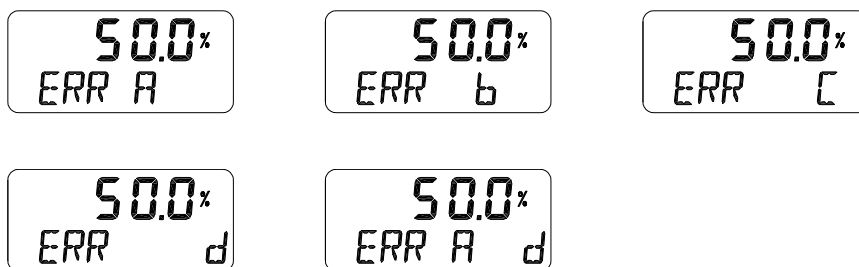





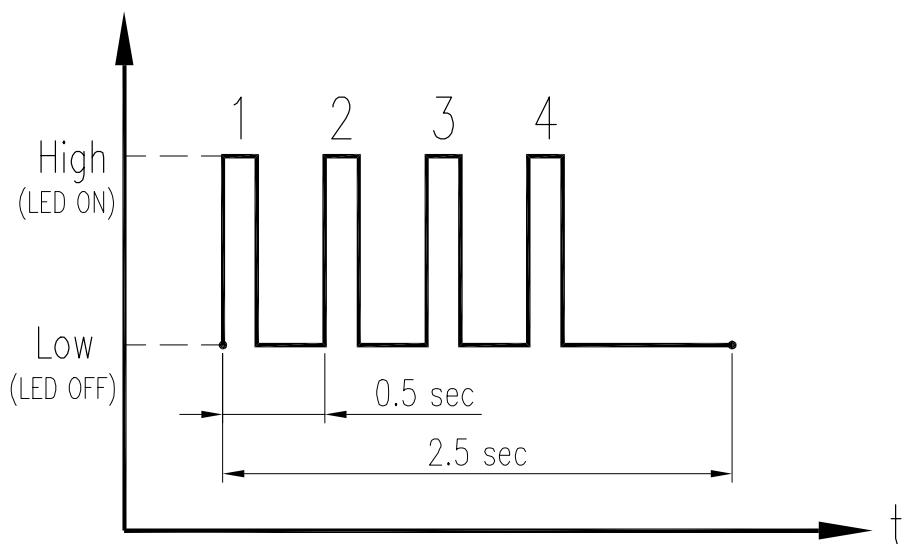













In case different errors occurred repetitively.

2) Error Code Indication – Non LCD Type



LED ON	LED OFF	LED ON ↔ OFF

		LED Flash			
Error Code (Number of Flash)	TIME(Sec)	0.5 Sec	0.5 Sec	0.5 Sec	0.5 Sec
	ERR A (1 Time)				
ERR B (2 Times)					
ERR C (3 Times)					
ERR D (4 Times)					

You can check the error codes by referring to the number of LED flashes. For example, if the LED flashes once it's ERR A, ERR B is for twice, ERR C is for three times, and ERR D is for four times. If errors A, B, C and D occur simultaneously, LED will flash in the order of errors A, B, C, D and repeat. If there is duplicate error, resolve them in order of A,B,C,D.

Error Code	Error Description & Cause	Instructions
ERR A	<ul style="list-style-type: none"> ➤ If feedback lever's rotating angle is excessively low. 	<ul style="list-style-type: none"> ➤ Re-adjust zero point (4 mA, 0 %) and end point (20 mA, 100 %) of the feedback lever to have larger rotating angle.
ERR b	<ul style="list-style-type: none"> ➤ If 5 point calibration is not set in order. 4 mA(0 %) → 8 mA(25 %) → 12 mA(50 %) → 16 mA(75 %) → 20 mA(100 %). ➤ If setting point is overlapping. 	<ul style="list-style-type: none"> ➤ Re-perform 5 point calibration from 4 mA(0 %) to 20 mA(100 %) in order.
ERR C	<ul style="list-style-type: none"> ➤ NVM Error: ➤ Error occurred to the memory due to external environment factors such as noise or impact. 	<ul style="list-style-type: none"> ➤ Re-perform 5 point calibration from 4 mA(0 %) to 20 mA(100 %) in order.
ERR d	<ul style="list-style-type: none"> ➤ If difference between TR ZERO value and TR END value off the feedback is too narrow. ➤ (when difference value is within 0.5 mA between TR ZERO and TR END) 	<ul style="list-style-type: none"> ➤ Reset TR ZERO and TR END values by hand calibration mode.

6 LCD Operating Flow Chart

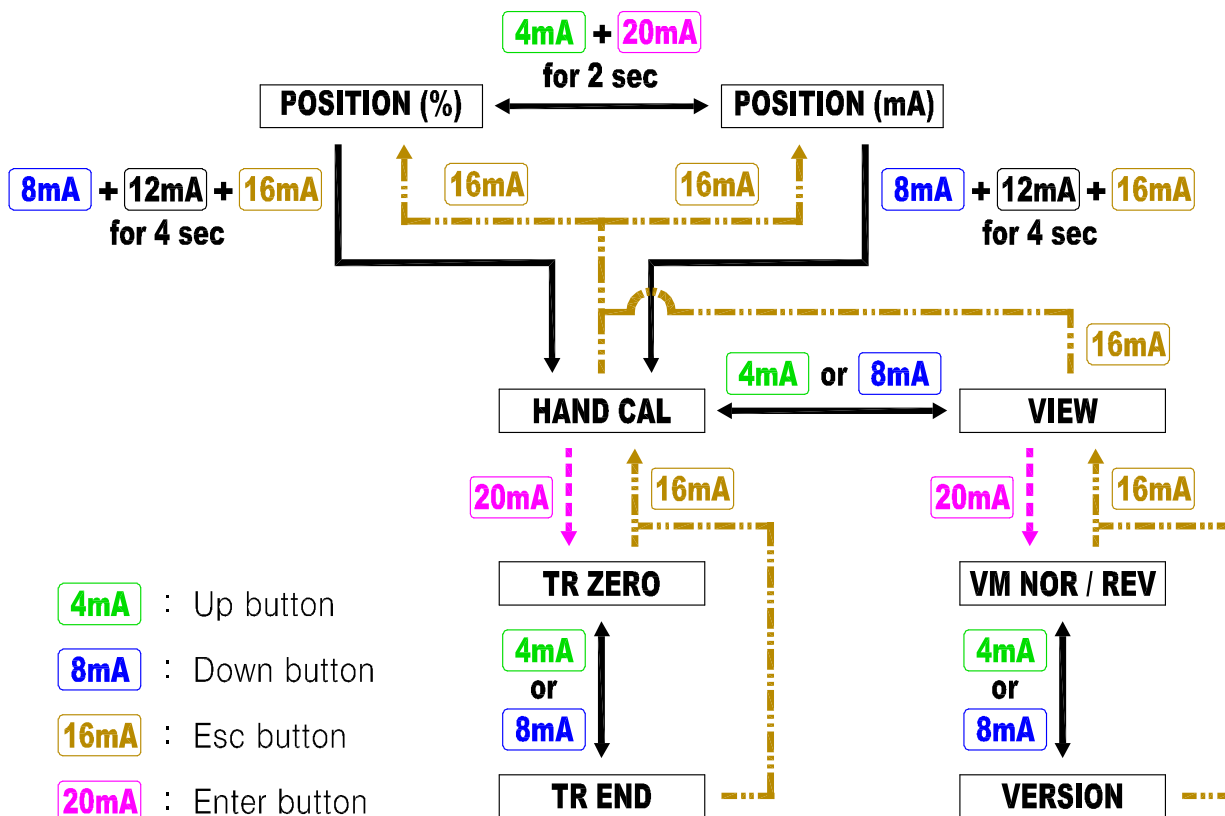

2022-03-03

Fig. 6-1: Entering Hand Cal mode or View mode

7 Troubleshooting and repair

1) There is no output current from the position transmitter.

- Check supplied voltage to the position transmitter.
- Check if the power is connected properly to the position transmitter. Also check terminal connections and polarity if they are setup properly.

2) There is much difference between the input value to the positioner and output value from the position transmitter.

- Check the voltage and input current to the positioner.
- Low voltage may lead to low input current value.
- Check the supplied voltage to the position transmitter if it is sufficient.
- Check the condition of positioner installation. If it is not installed properly, refer to the installation manual and re-install.
- Re-adjust positioner's zero and span. If the positioner's zero and span are inaccurately set, error value will be high and it will affect the linearity.
- Check the condition of position transmitter installation. If it is not installed properly, refer to the installation manual and re-install.
- Re-adjust position transmitter's zero and span. If the position transmitter's zero and span are inaccurately set, error value will be high and it will affect the linearity.

3) The output current of the positioner transmitter is disturbed.

- The position transmitter's circuit board and enclosure are grounded together as factory default setting to discharge any noise coming in through the power line. However, the noise could still enter the unit through the enclosure and may cause disturbance to the output current. To prevent such disturbance, disconnect the grounded circuit board from the enclosure by removing the Jumper on the circuit board which can be seen after removing the COVER PCB.

4) The output current value of the position transmitter has sudden dramatic changes.

- Check if the position transmitter's lever is horizontally at 50 % position or is at the middle point of the total travel range. If not, position transmitter should be re-installed or re-adjusted so the lever will be positioned in the middle.
- Re-position the potentiometer gear inside the position transmitter. Potentiometer is placed underneath the circuit board of the position transmitter. Potentiometer's resistance range is 0 ~ 10 K Ω and from 50 % travel of the position transmitter, approximately 5 k Ω resistance value can be read.

※ Refer to below instructions for detailed position adjustment of the potentiometer gear.

5) Position adjustment of the potentiometer gear.

Factory default setting is set to have 12 mA output signal when the feedback lever is at 50 % position. If however, factory default setting has been changed due to transport, installation, vibration or any other factors, please refer to below instructions for re-adjustment procedure.

Warning



- Power must be disconnected before adjusting the position of the potentiometer gear.
 - Pay close attention when adjusting the potentiometer gear. Adjust ONLY when it is necessary.
 - Be careful not to damage any main elements and circuits of the PCB board during removing and assembling the PCB board.
 - Be careful not to apply too much force to the wires when disconnecting the potentiometer and PCB board.
-
- a) Disassemble upper PCB of the position transmitter. When disassembling, connectors to the potentiometer and PCB board should also be disconnected and be careful not to apply too much force.
 - b) Remove the Stopper Bolt that fixes the potentiometer gear in place and remove the potentiometer gear from the main shaft gear by pulling it by hand.
 - c) Fix the feedback lever to 50 % position.
 - d) Use ohmmeter to measure resistance value by inserting 0.2 pie metal pins into two of the connector holes (out of 3 holes) including the middle hole and make contact using the probe.
 - e) Turn the potentiometer gear so the resistance value will become nearly 5 kΩ.
 - f) When adjustment of resistance value is done, assemble the potentiometer gear to the main shaft gear. Put the Stopper Bolt in its place. While tightening the Stopper Bolt, make sure the gears do not deviate and stop tightening when there is small gap between the Stopper Bolt and PTM Bracket. This is to avoid too much force between the gears so they would be engaged with the force coming from the PTM Spring which would prevent the gears from wearing out.
 - g) Connect the potentiometer to the PCB board connector.
 - h) Reassemble the PCB board to the position transmitter unit. Be careful not to damage or press down the wires during reassembling.

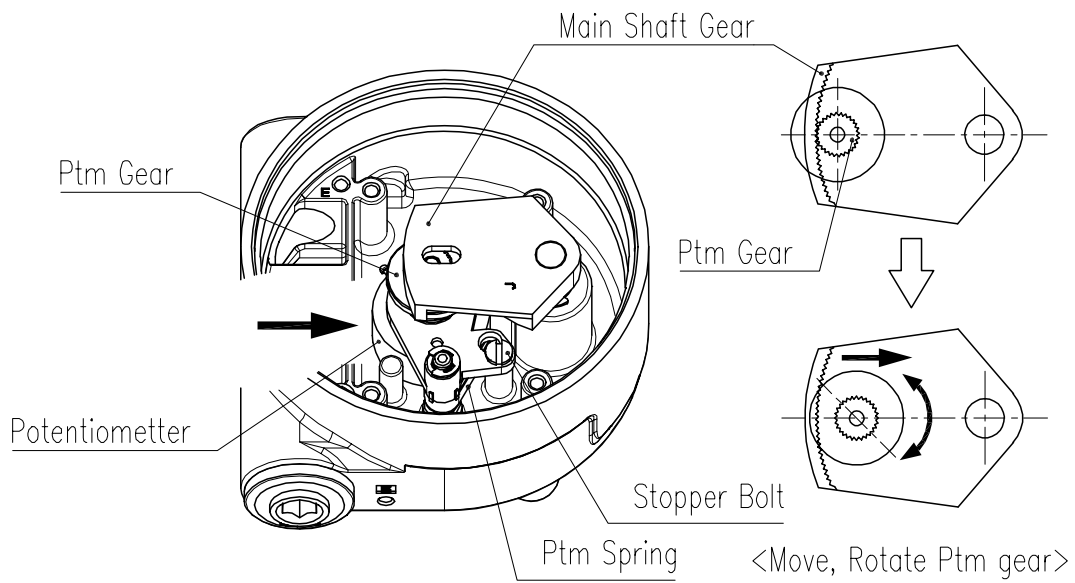

Fig. 7-1: Position adjustment of linear potentiometer gear

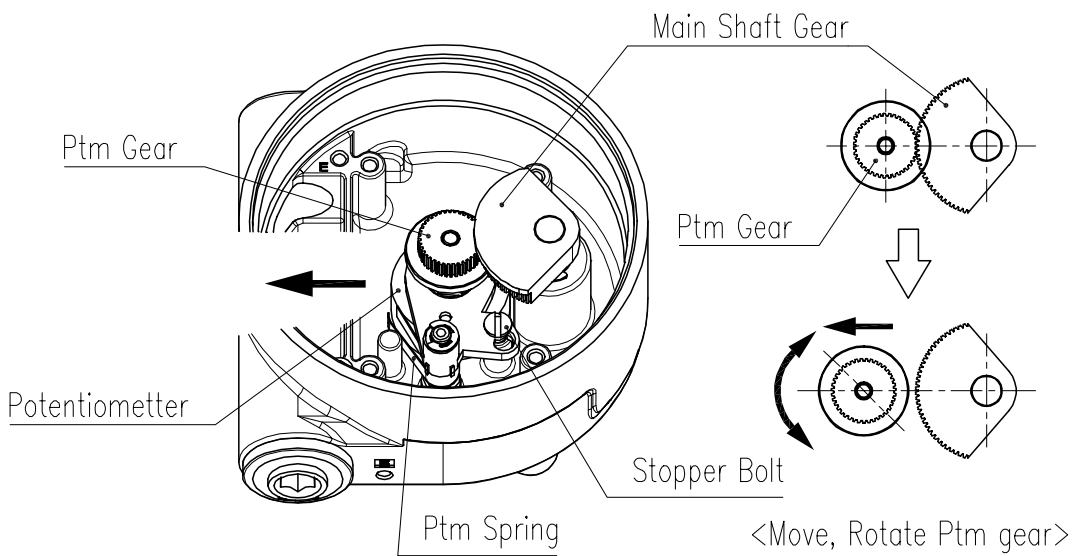

Fig. 7-2: Position adjustment of Rotary potentiometer gear

Manufacturer: Rotork YTC Limited

Address: 81, Hwanggeum-ro, 89 Beon-gil, Yangchon-eup, Gimpo-si, Gyeonggi-do, South Korea

Postal code: 10048

Tel: +82-31-986-8545

Fax: +82-70-4170-4927

Email: ytic.sales@rotork.com

Homepage : <http://www.ytc.co.kr>

Issued : 2023-07-11

Copyright © Rotork YTC Limited. All Rights Reserved.