

ITD32, IBP21, IBP21S, IBP30, ISM21 and IFT14

Steam Traps with Integral Spiratec Sensors

Installation and Maintenance Instructions

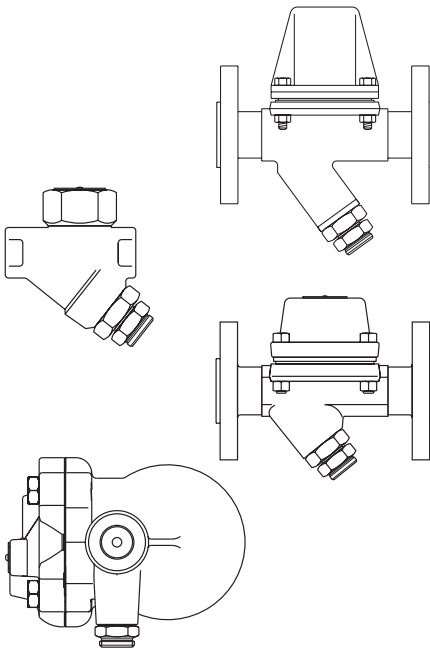

1. Safety information
2. General product information
3. Installation
4. Maintenance
5. Spare parts

1. Safety information

Safe operation of these products can only be guaranteed if they are properly installed, commissioned, used and maintained by qualified personnel (see Section 11 on this document) in compliance with the operating instructions. General installation and safety instructions for pipeline and plant construction, as well as the proper use of tools and safety equipment must also be complied with.

1.1 Intended use

Referring to the Installation and Maintenance Instructions, name-plate and Technical Information Sheet, check that the product is suitable for the intended use/application.

The products listed below comply with the requirements of the European Pressure Equipment Directive 97/23/EC and carry the  mark when so required.

The products fall within the following Pressure Equipment Directive categories:

Product		Group 2 Gases	Group 2 Liquids
FT14, FT14HC, FTS14 and IFT14	DN15 - DN40 (FT14HC DN25 only)	SEP	SEP
	DN50	1	SEP
FTGS14, IFTGS14		SEP	SEP
IBP21S,IBP30	DN15 - DN25	SEP	SEP
ITD32	DN15 - DN20	SEP	SEP
IBP21, ISM21	DN15 - DN20	SEP	SEP

- i) The products have been specifically designed for use on steam, air or water/condensate which are in Group 2 of the above mentioned Pressure Equipment Directive. The products' use on other fluids may be possible but, if this is contemplated, Spirax Sarco should be contacted to confirm the suitability of the product for the application being considered.
- ii) Check material suitability, pressure and temperature and their maximum and minimum values. If the maximum operating limits of the product are lower than those of the system in which it is being fitted, or if malfunction of the product could result in a dangerous overpressure or overtemperature occurrence, ensure a safety device is included in the system to prevent such over-limit situations.
- iii) Determine the correct installation situation and direction of fluid flow.
- iv) Spirax Sarco products are not intended to withstand external stresses that may be induced by any system to which they are fitted. It is the responsibility of the installer to consider these stresses and take adequate precautions to minimise them.
- v) Remove protection covers from all connections before installation.

1.2 Access

Ensure safe access and if necessary a safe working platform (suitably guarded) before attempting to work on the product. Arrange suitable lifting gear if required.

1.3 Lighting

Ensure adequate lighting, particularly where detailed or intricate work is required.

1.4 Hazardous liquids or gases in the pipeline

Consider what is in the pipeline or what may have been in the pipeline at some previous time. Consider: flammable materials, substances hazardous to health, extremes of temperature.

1.5 Hazardous environment around the product

Consider: explosion risk areas, lack of oxygen (e.g. tanks, pits), dangerous gases, extremes of temperature, hot surfaces, fire hazard (e.g. during welding), excessive noise, moving machinery.

1.6 The system

Consider the effect on the complete system of the work proposed. Will any proposed action (e.g. closing isolation valves, electrical isolation) put any other part of the system or any personnel at risk?

Dangers might include isolation of vents or protective devices or the rendering ineffective of controls or alarms. Ensure isolation valves are turned on and off in a gradual way to avoid system shocks.

1.7 Pressure systems

Ensure that any pressure is isolated and safely vented to atmospheric pressure. Consider double isolation (double block and bleed) and the locking or labelling of closed valves. Do not assume that the system has depressurised even when the pressure gauge indicates zero.

1.8 Temperature

Allow time for temperature to normalise after isolation to avoid danger of burns and consider whether protective clothing (including safety glasses) is required. The FTS14 is fitted with a viton seal and must not be subjected to temperatures above 315 °C (599 °F). Above this temperature toxic fumes may be given off. Avoid inhalation of fumes or skin contact.

1.9 Tools and consumables

Before starting work ensure that you have suitable tools and/or consumables available. Use only genuine Spirax Sarco replacement parts.

1.10 Protective clothing

Consider whether you and/or others in the vicinity require any protective clothing to protect against the hazards of, for example, chemicals, high/low temperature, radiation, noise, falling objects, and dangers to eyes and face.

1.11 Permits to work

All work must be carried out or be supervised by a suitably competent person. Installation and operating personnel should be trained in the correct use of the product according to the Installation and Maintenance Instructions.

Where a formal 'permit to work' system is in force it must be complied with. Where there is no such system, it is recommended that a responsible person should know what work is going on and, where necessary, arrange to have an assistant whose primary responsibility is safety.

Post 'warning notices' if necessary.

1.12 Handling

Manual handling of large and/or heavy products may present a risk of injury. Lifting, pushing, pulling, carrying or supporting a load by bodily force can cause injury particularly to the back. You are advised to assess the risks taking into account the task, the individual, the load and the working environment and use the appropriate handling method depending on the circumstances of the work being done.

1.13 Residual hazards

In normal use the external surface of the product may be very hot. If used at the maximum permitted operating conditions the surface temperature of some products may reach temperatures in excess of 250 °C (482 °F).

Many products are not self-draining. Take due care when dismantling or removing the product from an installation (refer to 'Maintenance instructions').

1.14 Freezing

Provision must be made to protect products which are not self-draining against frost damage in environments where they may be exposed to temperatures below freezing point.

1.15 Safety information

See the relevant Sections of the attached Installation and Maintenance Instructions for specific details relating to these products.

1.16 Disposal

Unless otherwise stated in the Installation and Maintenance Instructions, this product is recyclable and no ecological hazard is anticipated with its disposal providing due care is taken.

The FTS14 is fitted with a viton seal. Special care must be taken to avoid potential health hazards associated with decomposition/burning of the seal.

1.17 Returning products

Customers and stockists are reminded that under EC Health, Safety and Environment Law, when returning products to Spirax Sarco they must provide information on any hazards and the precautions to be taken due to contamination residues or mechanical damage which may present a health, safety or environmental risk. This information must be provided in writing including Health and Safety data sheets relating to any substances identified as hazardous or potentially hazardous.

2. Product information

Warning

The cover gasket on the IBP21, IBP21S, IBP30, ISM21 and IFT14 contains a thin stainless steel support ring, which may cause physical injury if it is not handled and disposed of carefully.

The Spirax Sarco range of steam traps with integral sensors has been designed for installation into the steam line without the need for an extra sensor chamber.

The following options are available:-

ITD32	Stainless steel thermodynamic type trap	ITD32L	with integral sensor, low capacity
		ITD32H	with integral sensor, high capacity
		ITD32LA	with integral sensor, low capacity and anti-air-binding disc
		ITD32HA	with integral sensor, high capacity and anti-air-binding disc
IBP21	Steel balanced pressure type trap		
IBP21S	Stainless steel balanced pressure type trap		
IBP30	Steel balanced pressure type trap		
ISM21	Steel bimetallic type trap		
IFT14	SG iron Ball float type trap		

They can be supplied with an integral sensor to detect waterlogging and steam leakage (WLS1) or for steam leakage only (SS1). All trap types can be simply integrated into all existing Spiratec monitoring systems.

Please refer to the relevant Installation and Maintenance Instructions when connecting to R1C (IM-P087-33) or R16C (IM-P087-21 and IM-P087-22) automatic monitors.

IBP21 and IBP21S

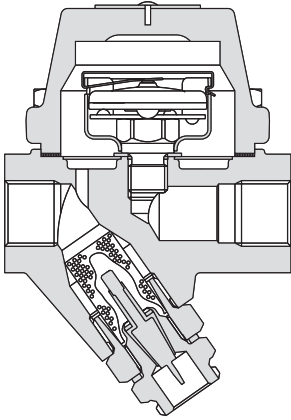

IBP30

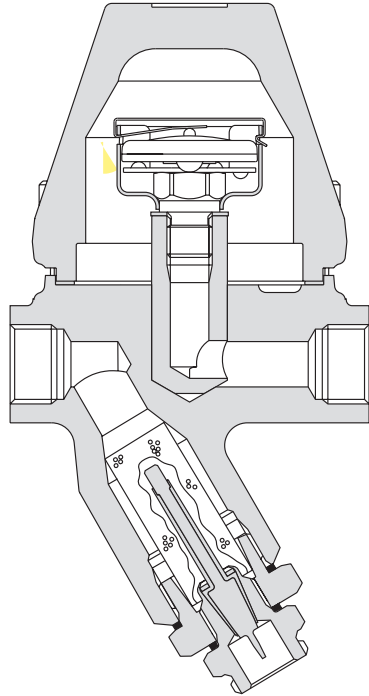

ITD32

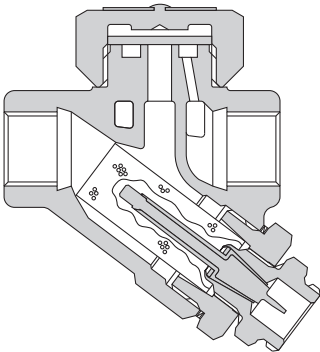

ISM21

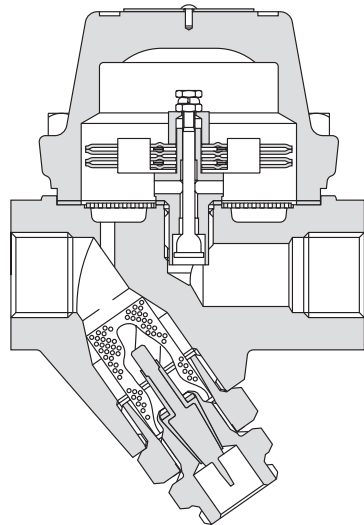

IFT14

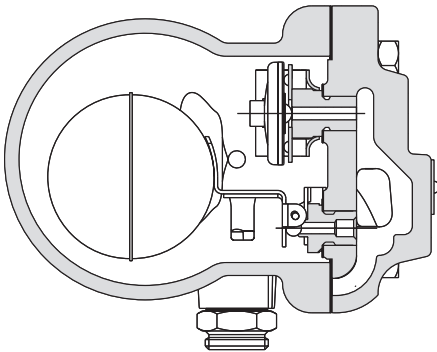

Limiting conditions (ISO 6552)

IBP21 and IBP21S IBP30 ITD32

Steam trap	ITD32		IBP21		IBP21S		IBP30	
	(psi g) °C	bar g (°F)	(psi g) °C	bar g (°F)	(psi g) °C	bar g (°F)	(psi g) °C	bar g (°F)
Maximum body design conditions	PN63		PN25		PN25		PN40	
PMA - Maximum allowable pressure	63	(913)	25	(362)	25	(362)	40	(580)
TMA - Maximum allowable temperature	400	(752)	400	(752)	400	(752)	400	(752)
PMO - Maximum operating pressure	32	(464)	21	(304)	21	(304)	30	(435)
TMO - Maximum operating temperature	240	(464)	240	(464)	240	(464)	240	(464)
Designed for a maximum cold hydraulic test pressure of:	95	(1377)	38	(551)	38	(551)	60	(870)
For further details see:	TI-P614-01		TI-P617-01		TI-P617-02		TI-P617-03	

IFT14 ISM21

Steam trap	ISM21		IFT14	
	bar g °C	(psi g) (°F)	bar g °C	(psi g) (°F)
Max. body design conditions	PN25		PN16	
PMA - Maximum allowable pressure	25	(362)	16	(232)
TMA - Maximum allowable temperature	400	(752)	250	(482)
PMO - Maximum operating pressure	21	(304)	14	(203)
TMO - Maximum operating temperature	240	(464)	240	(464)
Designed for a maximum cold hydraulic test pressure of:	38	(551)	24	(348)
For further details see:	TI-P618-01		TI-P615-01	

3. Installation

Note: Before actioning any installation observe the 'Safety information' in Section 1.

All traps must be installed in horizontal pipework, preferably preceded by a small dropleg. Suitable isolation valves must be installed to allow for safe maintenance or trap replacement. Where the trap discharges into a closed return system a non-return valve should be fitted downstream to prevent return flow, (on the ITD32 the non-return valve should be positioned 1 metre downstream of the trap outlet). Remove all packaging and protective covers and ensure all connection ports are clear from obstruction. Always open isolation valves slowly until normal operating conditions are achieved - this will avoid system shocks. Check for leaks and correct operation. Always ensure the correct tools, safety procedures and protective equipment are used at all times. When welding IBP21, IBP21S, IBP30 and ISM21 traps into the pipeline, there is no need to remove the element/capsule providing the welding is done by the electric arc method.

Note: The trap is supplied with a plug in the sensor adapter. It is recommended that the trap be operated under normal conditions for 24 hours before the plug is removed. This will allow any pipeline debris to be removed from the strainer prior to the sensor being installed. Failure to complete this commissioning process may affect the operation of the sensor. Before fitting the sensor, the trap must be isolated from both supply line and return line, and any pressure allowed to safely normalise to atmosphere. The trap should then be allowed to cool. Remove the plug from the adapter ensuring the trap is securely held and replace with the sensor. Screw into the adapter ensuring the gasket is centralised. Tighten to the recommended tightening torque. If a waterlogging sensor is to be fitted it will be necessary to carry out the installation procedure in IM-P087-34 which accompanies the sensor.

4. Maintenance

Note: Before actioning any maintenance program observe the 'Safety information' in Section 1.

4.1 General information

Maintenance can be completed with the trap in the pipeline. It is recommended that new gaskets and spares (see Section 5) are used whenever maintenance is undertaken. Ensure that the correct tools and necessary protective equipment are used at all times. When maintenance is complete open isolation valves slowly and check for leaks.

Note: The sensor should be removed periodically to inspect and clean the insulation as a build-up of pipeline residue may affect the function of the sensor. Frequency of inspection will be dictated by condensate quality. If pitting of the insulation occurs, a new sensor should be fitted.

More precise service information is given in the following Sections:

IBP21, IBP21S, IBP30, and ISM21	See Section 4.2
ITD32	See Section 4.3
IFT14	See Section 4.4

4.2 IBP21, IBP21S, IBP30 and ISM21 service information

How to fit flat screen, capsule and seat assembly (IBP21, IBP21S and ISM21)

Remove cover nuts and bolts. On the IBP21 and IBP21S undo the clip holding the capsule on to the mounting frame, remove capsule and spacer plate and unscrew valve seat from the body. Replace new gasket, mounting frame and valve seat using a suitable thread sealant such as STAG, ensuring the flat strainer screen is centralised during tightening to the recommended torque (see Table 2). On the ISM21 the element assembly can be removed by undoing the seat. Refit new capsule and spacer plate and then replace clip or complete new element. Ensure that the flat screen is located centrally. Fit new cover gasket and retighten cover nuts evenly to the recommended tightening torque.

How to fit Y-type strainer screen

If a waterlogging sensor is fitted, it will be necessary to disconnect the wiring at the terminal block. Undo and remove the sensor adapter (the sensor does not have to be removed from the adapter). Clean or replace the screen as required. Replace the screen and sensor assembly, ensuring that the screen is located centrally, and a new gasket is fitted (IBP21S and IBP30 only), but ensure that the joint faces are clean. A fine smear of Molybdenum Disulphide grease should be applied to the first few threads. Tighten to the recommended tightening torque (see Table 1). Reconnect the waterlogging sensor as described in IM-P087-34.

How to replace or clean the sensor

If a waterlogging sensor is fitted, it will be necessary to disconnect the wiring at the terminal block. Remove the sensor from the adapter. This can be done in line so long as the adapter is securely held in place. Clean the sensor insulation. If pitting of the insulation occurs, a new sensor should be fitted. Replace new sensor and screw into the adapter, ensuring the gasket is centralised. Tighten to the recommended tightening torque. Reconnect the waterlogging sensor as described in IM-P087-34.

Ensure that any sensor fitted to the IBP30 has a letter 'L' stamped on the hexagonal face. Sensors with the letter 'L' on the hexagonal face must not be fitted to IBP21, IBP21S or ISM21 traps.

IBP30

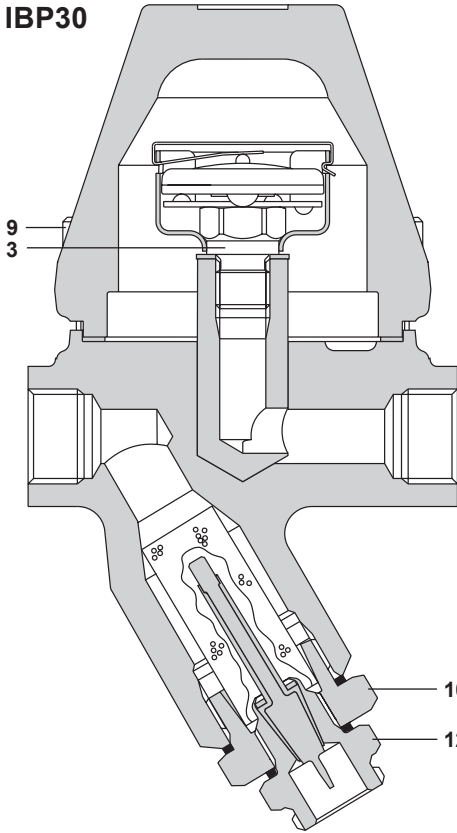

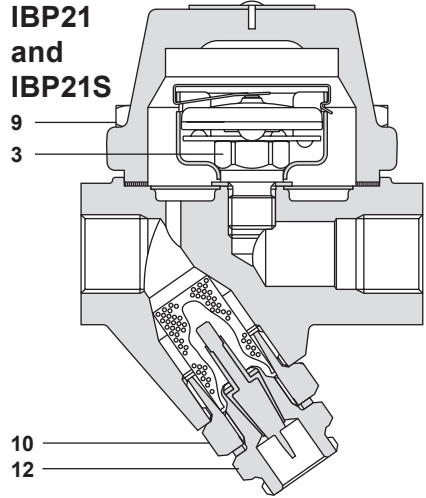

IBP21 and IBP21S

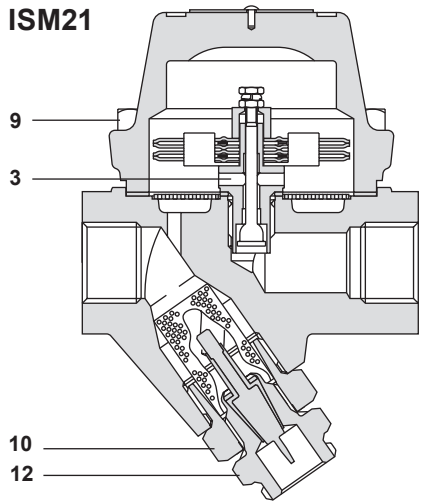

ISM21



**Table 1
Recommended
tightening torques**

Item	Part		or mm		N m	(lbf ft)
3		17			50 - 55	(37 - 40)
9	IBP21, ISM21	13	M8 x 35		18 - 22	(13 - 16)
	IBP21S		M10 x 30		18 - 22	(13 - 16)
10	IBP30		M10 x 42		20 - 27	(15 - 20)
	IBP21, IBP21S ISM21	27	M24		120 - 135	(88 - 99)
12	IBP30	32			170 - 190	(125 - 140)
12		24			50 - 55	(37 - 40)

4.3 ITD32 service information

Repair of disc/seat

Remove the insulating cover if fitted and unscrew the cap using a suitable socket or spanner. Do not use Stillsons or a wrench of a similar type which may cause distortion of the cap.

If the disc and body seating faces are only slightly worn, they can be refaced by lapping individually on a flat surface such as a surface plate. A figure-of-eight motion and a little lapping compound give the best results.

If the wear is too great to be rectified by simple lapping, the seating faces on the body must be ground flat and then lapped. The disc should be renewed. The total amount of metal removed in this way should not exceed 0.25 mm (0.010").

When reassembling, the disc is normally placed with the grooved side in contact with the seating faces. The screw-on cap does not require a gasket, but a suitable high temperature anti-seize grease should be applied to the threads. Tighten to the recommended torque (see Table 2).

How to fit the strainer screen

If a waterlogging sensor is fitted, it will be necessary to disconnect the wiring at the terminal block.

Undo and remove the sensor adapter (the sensor does not have to be removed from the adapter). Clean or replace the screen as required. Replace the screen and sensor assembly, ensuring that the screen is located centrally. Fit new gasket and ensure that the joint faces are clean. A fine smear of Molybdenum Disulphide grease should be applied to the first few threads. Tighten to the recommended tightening torque. Reconnect the waterlogging sensor as described in IM-P087-34. The ITD32L and ITD32H are fitted with a 0.8 mm perforated screen. The ITD32LA and ITD32HA are fitted with a 100 mesh screen.

How to replace or clean the sensor

If a waterlogging sensor is fitted, it will be necessary to disconnect the wiring at the terminal block.

Remove the sensor from the adapter. This can be done in line so long as the adapter is securely held in place. Clean the sensor insulation. If pitting of the insulation occurs, a new sensor should be fitted. Replace new sensor and screw into the adapter ensuring the gasket is centralised. Tighten to the recommended tightening torque (see Table 2). Reconnect the waterlogging sensor as described in IM-P087-34.

Ensure that any sensor fitted to the ITD32 has a letter 'L' stamped on the hexagonal face.

ITD32

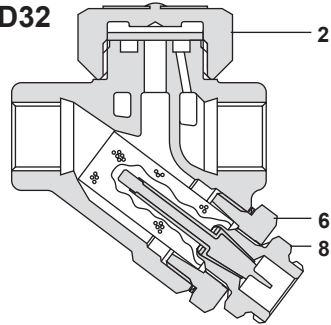

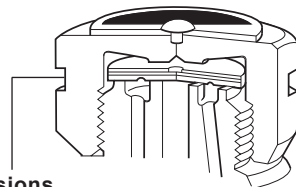
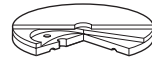

Table 2 Recommended tightening torques

Item	Part	or		N m	(lbf ft)
					
2	ITD32L and LA	36		135 - 150	(99 - 110)
	ITD32H and HA	41		135 - 150	(99 - 110)
6	IBP21S	32	M28	170 - 190	(125 - 140)
8	IBP30	24		50 - 55	(37 - 40)

ITD32LA and ITD32HA
Anti-air-binding disc



Groove identifies LA and HA versions

4.4 IFT14 service information

How to fit the main valve assembly

Undo the cover bolts and lift off the cover. Remove the complete float assembly by undoing the two screws. Remove the main valve seat. Ensure seat/gasket faces are clean and dry. Fit new seat and gasket, tighten to the recommended tightening torque (see Table 3). Fit complete new float assembly by tightening the assembly set screws to the recommended tightening torque. Refit cover using new gasket and retighten cover bolts evenly to the recommended tightening torque.

How to fit the air vent assembly

Remove the spring clip, capsule, spacer plate and unscrew the seat. Fit new seat, gasket and frame and tighten to the recommended tightening torque. Assemble spacer plate, fit new capsule and clip. Align complete air vent horizontally so that the frame clears the cover. Refit cover using new gasket and retighten cover bolts evenly to the recommended tightening torque.

How to replace or clean the sensor

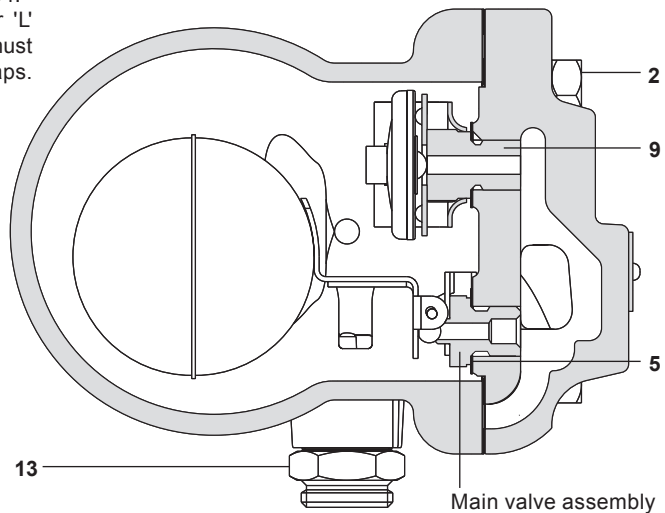

If a waterlogging sensor is fitted, it will be necessary to disconnect the wiring at the terminal block. Remove the sensor from the trap. Clean the sensor insulation. If pitting of the insulation occurs, a new sensor should be fitted. Replace new sensor, ensuring the gasket is centralised. Tighten to the recommended tightening torque. Reconnect the waterlogging sensor as described in IM-P087-34.

Sensors with the letter 'L' on the hexagonal face must not be fitted to IFT14 traps.



*Item 7 (main valve assembly screws) not shown

Table 3 Recommended tightening torques

Item	 or mm		N m	(lbf ft)
2	17	M10 x 30	45 - 55	(33 - 40)
5	17		50 - 55	(37 - 40)
*7	Pozidrive	M4 x 6	2.5 - 3.0	(1.8 - 2.2)
9	17		2.5 - 3.0	(37 - 40)
13	24		50 - 55	(37 - 40)

5. Spare parts

5.1 How to order spares

Always order spare parts by using the description given in the column headed 'Available spares' and state the size, model number and pressure rating of the trap.

Example 1: Strainer screen and gasket for Spirax Sarco ½" ITD32 steam trap with integral sensor.

Example 2: Capsule and seat assembly set, having 'E' fill, for Spirax Sarco ½" IBP21 steam trap with integral sensor.

5.2 Available spares for the ITD32 range

The following options are available:-

ITD32L with integral sensor, low capacity

ITD32H with integral sensor, high capacity

ITD32A with integral sensor, low capacity and anti-air-binding disc

ITD32HA with integral sensor, high capacity and anti-air-binding disc

Spare parts are available as indicated below.

No other parts are supplied as spares.

Disc (3 off) for ITD32L or ITD32H	3
Disc and strainer screen for ITD32LA or ITD32HA	3, 4, 5
Strainer screen and gasket for ITD32L or ITD32H	4, 5
Sensor adapter gasket (3 off)	5
Sensor and sensor gasket	7, 8
Insulating cover for ITD32	(not shown)

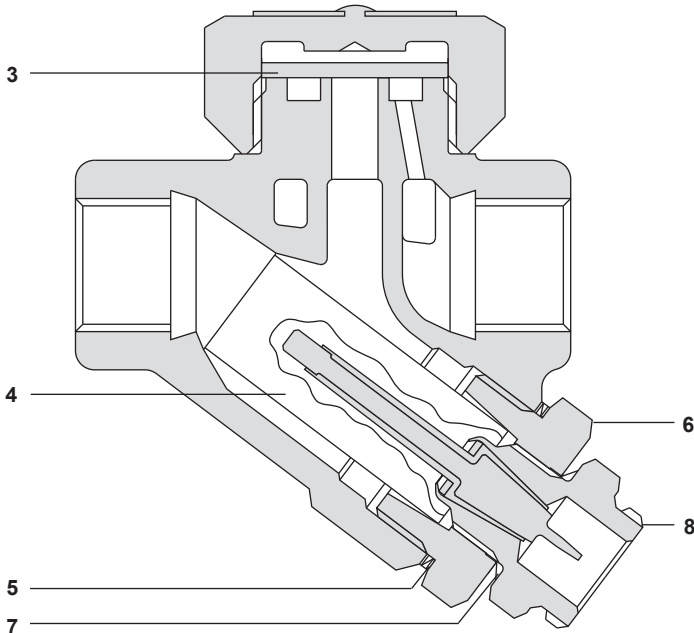

5.3 Available spares for IBP21, IBP21S, IBP30 and ISM21

Spare parts are available as indicated below.

No other parts are supplied as spares.

	IBP21/21S	IBP30	ISM21
Capsule and seat assembly set (state capsule filling)	2, 3, 14	2, 3, 14	-
Element set	-	-	2, 3, 4
Strainer screen, flat (3 off)	6	-	6
Y-type strainer screen, cylindrical (1 off)	5	5	5
Set of cover gaskets (3 off)	7	7	7
Sensor and sensor gasket	11, 12	11, 12	11, 12
Sensor adaptor gasket (3 off)	-	15	-

IBP21 and IBP21S

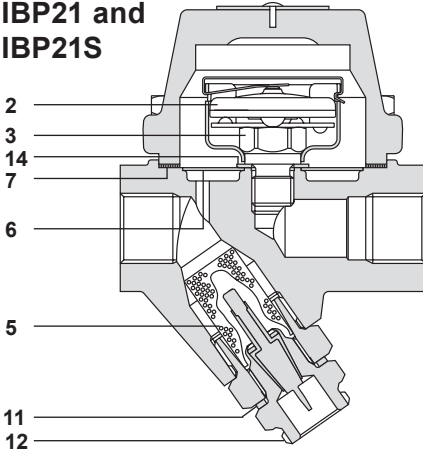

IBP30

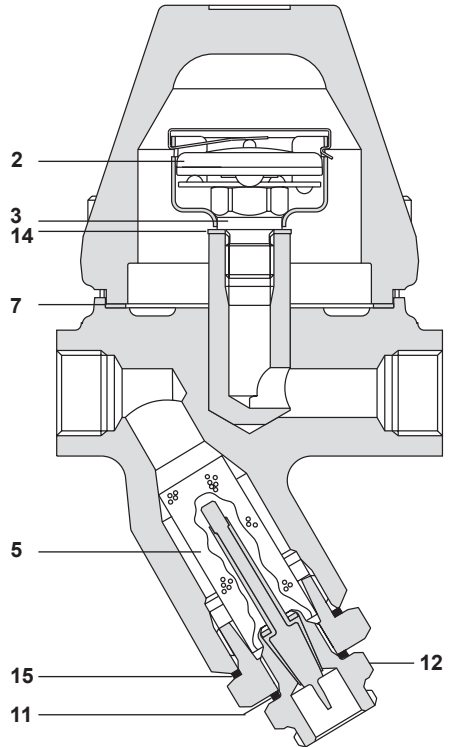

ISM21

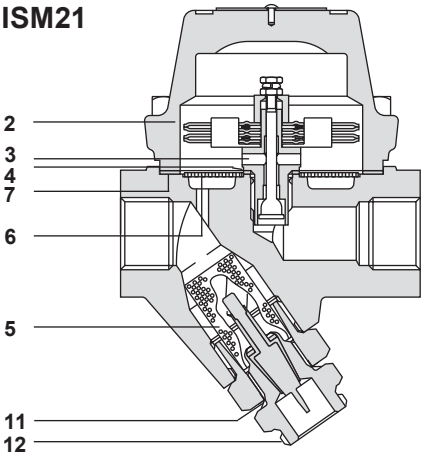

5.4 Available spares for IFT14

Spare parts are available as indicated below.
No other parts are supplied as spares.

Main valve assembly with float	3, 5, 6, 7 (2 off)*, 8, 10, 11
Air vent assembly	3, 6, 9
Cover gasket (packet of 3)	3
Sensor and sensor gasket	12, 13

* Item 7 (Main valve assembly screws) are not shown.

IFT14

