

Technical Datasheet



GR Series - Flameproof Pressure Switch

Models: GR2 & GR4

Key Features

- Compact and rugged design.
- Weatherproof IP66/NEMA 4.
- ATEX Flameproof CENELEC EEx d IIC option.
ATEX Intrinsically Safe ATEX Ex ia IIC option.
- Stainless steel body option NEMA 4X rating.
- Optional weatherproof, ATEX EEx e, ATEX Ex ia or ATEX.
- Flameproof EEx d IIC terminal enclosures.
- Variety of wetted parts including NACE MR-01-75 compatibility option.
- High over-range models up to 1000 bar (15,000 psi).
Ranges available between 0.25-700 bar (4-10,000 psi).
Static pressure up to 1000 bar (15,000 psi).
- Field adjustable.
- Hermetically sealed snap switch CSA listed.

Series Overview

- Launched in the mid-1990s, the Compact Series pressure switches provide users with a compact, robust and hermetically sealed switch for use in Safe and Hazardous Areas.
- The GR Series switches are all housed in a compact and rugged enclosure making them particularly suitable for panel mounting in harsh environments
- All models in the Compact Series come with hermetically sealed switch contacts and flying leads as standard.

Other products in the series include:

- Differential Pressure Switches: Model GR3/6
- Temperature Switches: Model GR7



Product applications

The GR Series is suitable for a wide range of applications in:

- Wellhead Control
- Hydraulic Power Units
- Chemical Injection Skids
- All panel applications where compact hazloc switches are needed

The choice of models available ensures that the GR Series is suitable for use in:

- Corrosive atmospheres
- Resistant to chemical attack

How can we help you?

Delta Mobrey offers fast, efficient and knowledgeable support when and where you need it. Please visit our website at www.delta-mobrey.com to find your local support centre or call us on:

+44 (0) 1252 729140

GR Series
Models: GR2 & GR4

How to order

Switches can be configured by selecting codes representing the desired features from the tables that follow. The chart below, describes how the model code is built up. For assistance in configuring a switch that best suits your needs, please contact your local sales office.

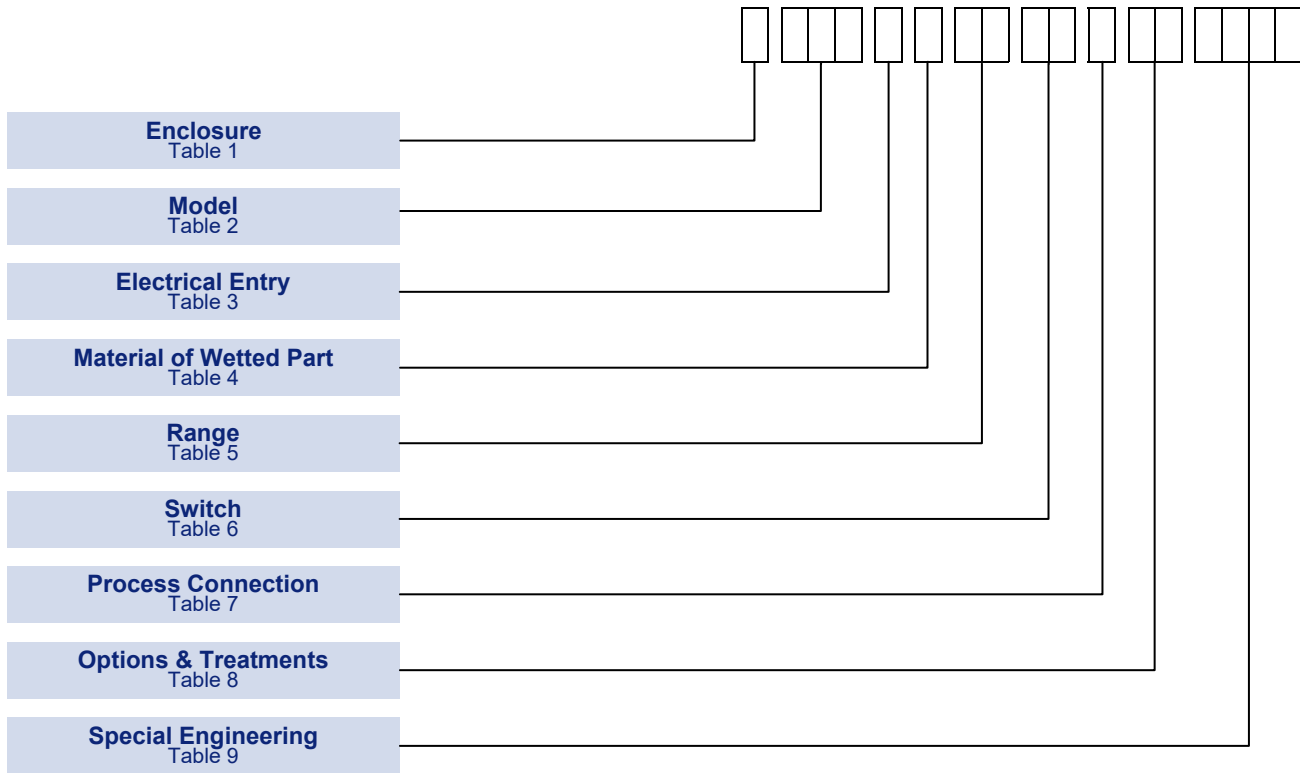

NOTE: Options shaded in the following tables are the most common options and are available on the quickest lead-times and at the lowest cost.

NOTE: Only the most common options are shown in this data sheet. Should you require a feature that is not shown, please contact your local sales office for further details.

Technical Specification

GR Series Models: GR2 & GR4	Accuracy:	Set point repeatability ± 1% of span at 20°C / 68°F ambient
	Storage Temperature:	-40 to +60°C / -13 to +140°F
	Ambient Temperature:	Certified Enclosures. Refer to Approvals and Tables 1 & 3 for limitations of ambient use
	Maximum Process Temperature:	Subject to appropriate installation practice, the component parts withstand up to +60°C (+140°F)
	Enclosure classification:	IP66 / NEMA 4X / Flameproof Ex d
	Switch output:	SPDT or DPDT snap action hermetically sealed microswitch
	Electrical rating:	See Table 6
	Process Connection:	Rc ¼ (BSP), ¼ NPT Internal, 1/2 NPT Internal, 1/2 NPT External
	Approximate Weight:	Enclosure Code "H", "W" & "5" 0.6kg / 1.32lb, "R" & "A" and "4" 0.9kg/1.98lb Terminal Enclosure Code "C", "D", "V" & "W" add 0.3kg/0.66lb, "J" add 1.1kg/2.42lb, "K" add 0.5kg/1.1lb

Electrical Entry

See **TECHNICAL DATA** and **DIMENSIONS** fig 1 to 4.

NOTE 1:

Other lengths available - please contact sales for engineering codes



NOTE 2:

Weatherproof terminal enclosure Code C can only be combined with Table 1 Enclosure Codes W and A

NOTE 3:

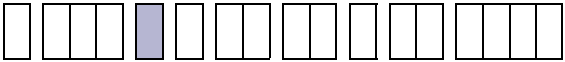
Intrinsically Safe terminal enclosure Code V and W can only be combined with Table 1 Enclosure Codes 4 and 5

TABLE 3 

	Code
Factory Sealed Flying Lead. See fig 1. Class 1, Groups A, B, C, D; Class II Groups E, F, G. 0.45m/18in. Long flying lead (Note 1). With 1/2-14 NPT external conduit thread. <div style="float: right; text-align: center;">  </div>	A
Integral Weatherproof Terminal Enclosure. See fig 2. Glass filled polyester with weather protection to IP66/NEMA 4. Conduit entry tapped M20 x 1.5 (Note 2) Ambient temperature -20°C to 86°C.	C
Integral 'Increased Safety' Terminal Enclosure. See fig 2. Ex e IIC T6 (-20 to +40°C) Glass filled polyester With weather protection not less than IP66/NEMA 4. <div style="float: right; text-align: center;">  II 2G </div>	D
Integral 'Increased Safety' Terminal Enclosure. See fig 3. EEx e IIC T6 (-20 to +40°C) Hawke Type PL612. Glass filled polyester , with weather protection not less than IP66/NEMA 4.	J
Explosionproof Terminal Enclosure. See fig 4. CENELEC Exd IIC T6 (-20 to +40°C) Diecast aluminium alloy. Weather protection not less than IP66/NEMA 4. Conduit entry tapped 1/2-14 NPT. <div style="float: right; text-align: center;">  II 2G </div>	K
Intrinsically Safe Terminal Enclosure-With Screw Terminals. See fig 2. Ex ia IIC T6 (-20 to +40°C) Glass filled polyester with weather protection not less than IP66/NEMA 4. <div style="float: right; text-align: center;">  II 2G </div>	V
Intrinsically Safe Terminal Enclosure-With DIN Rail Mounted Terminals. See fig 2. Ex ia IIC T6 (-20 to +40°C) Glass filled polyester with weather protection not less than IP66/NEMA 4. <div style="float: right; text-align: center;">  II 2G </div>	W

Material of Wetted Parts

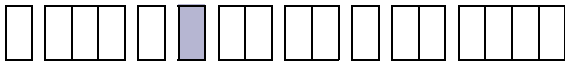
TABLE 4 

WELDED CONSTRUCTION

Codes S and T

For reduced risk against leakage under extreme or unusual conditions, the diaphragm may be welded directly to the process connection, eliminating the O-ring.

Maximum process temperature

For Code G&P: 60°C
 For Code A, K, S & T: 120°C

	Code
316 stainless steel diaphragm, process connection and Viton O-ring seal.	A
316 stainless steel diaphragm, process connection and Nitrile (Buna-N) O-ring seal.	G
Nickel alloy (Monel) diaphragm, 316 stainless steel process connection and Viton O-ring seal for applications as laid down in NACE MR 01-75.	K
Nickel alloy (Monel) diaphragm, 316 stainless steel process connection and Nitrile (Buna-N) O-ring seal.	P
316 stainless steel diaphragm and process connection. All welded construction.	S
Nickel alloy (Monel) diaphragm and process connection. All welded construction (suitable for NACE MR 01-75).	T

Setting Ranges

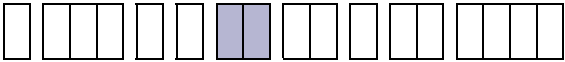
TABLE 5 

P_{max} = maximum working pressure

When ordering, please state units required. Range and set point will be in units preference.

 Applies to all ranges

Model	P_{max}		Range			
	bar	psi	Bar	Code	psi	Code
GR2	27	400	0.25 to 1.6	DB	4 to 25	DK
			0.4 to 2.5	DC	6 to 40	DP
			1.0 to 6	DE	16 to 100	DZ
GR2	70	1000	1.6 to 10	EA	25 to 160	EH
			2.5 to 16	EB	40 to 250	EM
GR2	112	1600	4.0 to 25	EC	60 to 400	ER
			10 to 40	ED	160 to 600	EW
			16 to 75	EF	250 to 1000	EE
GR2	115	2250	10 to 100	FA	160 to 1500	F6
GR4	600	8700	0.25 to 1.6	DB	4 to 25	DK
			0.4 to 2.5	DC	6 to 40	DP
			1.0 to 6	DE	16 to 100	DZ
			1.6 to 10	EA	25 to 160	EH
			2.5 to 16	EB	40 to 250	EM
			4.0 to 25	EC	60 to 400	ER
			10 to 40	ED	160 to 600	EW
			16 to 75	EF	250 to 1000	EE
			10 to 100	FA	160 to 1500	F6
			GR4	1000	15000	7 to 160
25 to 250	V7	350 to 3500				VC
50 to 400	W7	800 to 6000				W9
100 to 700	Y4	1600 to 10000				YF

Switch Options

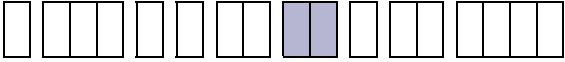
TABLE 6 

Model GR2/4								
CSA RATING	IEC947-5-1 / EN 60947-5-1 RATING						Contact	Code
	Designation & Utilization Category	Rated operational current I_e (A) At rated operational voltage U_e	U_i	U_{imp}	VA Rating			
					Make	Break		
11 Amps @ 110/250V AC and 5/0.5 Amps @ 30/125V DC Silver contacts	AC14 D300	0.6/0.3A @ 120/240 V AC	250V	800V	432	28	SPDT DPDT DPDT	HS
	DC13 R300	0.22/0.1A @ 125/250V DC						HD † HR ‡
5 Amps @ 250V AC and 2 Amps @ 30V DC Silver contacts with gold flash	AC14 D300	0.6/0.3A @ 120/240 V AC	250V	500V	432	28	SPDT DPDT DPDT	HP
	DC13 R300	0.22/0.1A @ 125/250V DC						HQ † HT ‡
1 Amp @ 125V AC and 1 Amp @ 30V DC Gold Alloy contacts—see note	AC14 E150	0.3A @ 120VAC	125V	500V	216	36	SPDT DPDT DPDT	HV HW † HY ‡

† 2 Single pole, double throw, simultaneous falling under pressure
‡ 2 Single pole, double throw, simultaneous rising under pressure

The switch contacts are hermetically sealed inside a stainless steel enclosure for protection against aggressive and corrosive atmospheres.

 CSA listing applies to the explosionproof hermetically sealed switch which is suitable for use in hazardous areas as defined by NEC Article 500, Class I Groups A, B, C, D Class II Groups E, F, G Division 1 and 2

NOTE: For low energy circuits e.g. 30V and up to 100mA, we recommend using gold alloy contact switches.
NOTE: For Enclosure codes 4 and 5, HS, HD and HR switching codes are unsuitable. Use gold contact switches.
 U_i = rated insulation voltage U_{imp} = rated impulse to withstand voltage across contacts.

GR Series
Models: GR2 & GR4

Process Connection

Other thread specifications and sizes are available without using adaptors.

Adaptors are available for applications where their use is permitted. Apply for details.

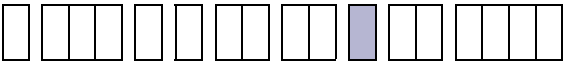
TABLE 7 

	Code
Rc 1/4 (1/4 BSP tr INT) to (ISO 7/1)	A
1/4—18 NPT INTERNAL	F
1/2—14 NPT INTERNAL	H
1/2—14 NPT EXTERNAL	J

**Not recommended for use over 600 bar/8700 psi. Refer to Table 5.*

Options & Treatments

Combinations available, apply for details.

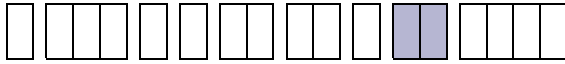
TABLE 8 

	Code
Tropicalisation High humidity atmospheres	01
Marine and Offshore Saline atmosphere or salt spray	02
Ammonia Process (wetted) parts and construction suitable for atmospheric ammonia	03
Oxygen Service Process (wetted) parts are cleaned for oxygen and are oil free	04
Pipe mounting Bracket Permits local 2" pipework to be utilized for mounting the instrument. Details on application.	10
Tag Stainless steel fixed to enclosure. Tag Stainless steel tied to enclosure.	20 30
No options or Treatments Use this code when Special Engineering is required without options and treatments	00
Epoxy Paint for aluminium enclosures W, H in Table 1	50

Special Engineering

Last 4 digits of model code only used when special engineering is required.



Refer to engineering

TABLE 9 

	Code
Please consult Delta sales engineering for special requirements	TBA

Performance Data

TABLE 10

Bar Units

Due to manufacturing tolerances the figures quoted in these tables are for guidance only.

MODEL GR2

TABLE 10A

Range		P _{max} bar	SWITCHING OPTIONS					
Code	bar		SWITCHING DIFFERENTIAL IN bar					
			HS	HD/HR	HP	HQ/HT	HV	HW/HY
DB	0.25 to 1.6	27	200	260	80	104	200	260
DC	0.4 to 2.5	27	320	416	128	166	320	416
DE	1 to 6	27	280	364	206	268	280	364
EA	1.6 to 10	70	430	450	300	390	430	450
EB	2.5 to 16	70	570	741	228	297	570	741
EC	4 to 25	112	1200	1560	480	624	1200	1560
ED	10 to 40	112	2700	3500	1200	1560	2700	3500
EF	16 to 75	112	3200	4160	1280	1664	3200	4160
FA	10 to 100	115	4300	5600	1720	2236	4300	5600

MODEL GR4

TABLE 10B

Range		P _{max} bar	SWITCHING OPTIONS					
Code	bar		SWITCHING DIFFERENTIAL IN bar					
			HS	HD/HR	HP	HQ/HT	HV	HW/HY
DB	0.25 to 1.6	600	260	340	200	260	260	340
DC	0.4 to 2.5	600	330	429	250	325	330	429
DE	1 to 6	600	880	1144	680	885	880	1144
EA	1.6 to 10	600	600	780	463	603	600	1144
EB	2.5 to 16	600	1300	1690	1000	1300	1300	1690
EC	4 to 25	600	1900	2470	1500	1950	1900	2470
ED	10 to 40	600	4200	5460	2200	2860	4200	5460
EF	16 to 75	600	4300	5590	3300	4300	4300	5590
FA	10 to 100	600	6500	8485	5000	6500	6500	8450
U7	7 to 160	1000	9400	12220	7300	9500	9400	12220
V7	25 to 250	1000	16000	20800	9000	11700	16000	20800
W7	50 to 400	1000	22000	28600	17000	22100	22000	28600
Y4	100 to 700	1000	37400	48620	30000	39000	37400	48620

MODEL GR2

TABLE 10C

PSI Units

Range		P _{max} psi	SWITCHING OPTIONS					
Code	psi		HS	HD/HR	HP	HQ/HT	HV	HW/HY
DK	4 to 25	400	2.9	3.8	1.2	1.5	2.9	3.8
DP	6 to 40	400	4.6	6	1.9	2.4	4.6	6
DZ	16 to 100	400	4.1	5.3	3	3.9	4.1	5.3
EH	25 to 160	1000	6.2	6.5	4.4	5.7	6.2	6.5
EM	40 to 250	1000	8.3	10.8	3.3	4.3	8.3	10.8
ER	60 to 400	1600	17	23	7	9	17	23
EW	160 to 600	1600	39	51	17	23	39	51
EE	250 to 1000	1600	46	60	19	24	46	60
F6	160 to 1500	2250	62	81	25	32	62	81

Performance Data

TABLE 10

PSI Units

Due to manufacturing tolerances the figures quoted in these tables are for guidance only.

MODEL GR4

TABLE 10D

Range		P _{max} psi	SWITCHING OPTIONS SWITCHING DIFFERENTIAL IN psi					
Code	psi		HS	HD/HR	HP	HQ/HT	HV	HW/HY
DK	4 to 25	8700	3.8	4.9	2.9	3.8	3.8	4.9
DP	6 to 40	8700	4.8	6.2	3.6	4.7	4.8	6.2
DZ	16 to 100	8700	13	17	10	13	13	17
EH	25 to 160	8700	9.0	11	7	9	9.0	11
EM	40 to 250	8700	19	25	15	19	19	25
ER	60 to 400	8700	28	36	22	28	28	36
EW	160 to 600	8700	61	79	32	41	61	79
EE	250 to 1000	8700	62	81	48	62	62	81
F6	160 to 1500	8700	94	123	73	94	94	123
UK	100 to 2300	15000	136	177	106	138	136	177
VC	350 to 3500	15000	232	302	131	170	232	302
W9	800 to 6000	15000	319	415	247	321	319	415
YF	1600 to 10000	15000	543	705	435	566	543	705

Electrical Connections

<p>Flying Lead High Duty PVC insulated 1.19mm²/18 AWG factory sealed flying leads. Rated insulation voltage UL/CSA 600 V.</p>
<p>Terminal Enclosures Suitable for conductor sizes up to 2.5mm²/14AWG non-pinching, clamped.</p>
<p>Earthing/Grounding An earthing facility is provided. Flying lead versions have separate earth/ground conductor. Terminal enclosures have additional internal earthing/grounding facility.</p>
<p>Dielectric Strength The electrical assembly is capable of withstanding *1.5kV between live parts and earth/ground and 500V between open contacts.</p>

Optional Extras

<p>Chemical Seals Chemical seals of our own or proprietary manufacture can be fitted when required.</p>
<p>Mounting Position/Location/Installation Vertical as shown, IN DIMENSIONS, taking care to avoid siting in locations that transmit excessive shock or vibration. For further advice contact our engineers.</p>
<p>Electrical Isolation These products are not suitable for electrical isolation. Always isolate circuit separately to carry out any electrical work.</p>
<p>Pollution degree (EN60947-5-1) All products rated IP66 are suitable for use in pollution degree 3. Ref. IEC 947-5-1.</p>

GR Series
Models: GR2 & GR4

Approvals

EUROPEAN DIRECTIVES



Low Voltage Directive (LVD) 2014/35/EU
Compliant to LVD

Pressure Equipment Directive (PED) 97/23/EC:

This product has a process connection size ≤ DN25 and is therefore categorised as Sound Engineering Practice (SEP) under Cat 3.3

ATEX Directive 2014/34/EU



FLAMEPROOF
Certificate No. BASEEFA02ATEX0214X
EN 60079-0:2012 + A11:2013*, EN 60079-1:2007*

For Zone 1 models (**Enclosure code H/R, see Table 1**)

II 2G Ex d IIC T6 (Tamb - 40°C Gb to + 65°C)
Ex d IIC T4 (Tamb - 40°C Gb to + 85°C)

INTRINSICALLY SAFE

Certificate No. BASEEFA06ATEX0091X
EN 60079-0:2012 + A11:2013*, EN 60079-11:2007, EN 60079-26:2004, EN 61241-0:2006, EN 61241-11:2006

For Zone 0 models (**Enclosure code 4/5, see Table 1**)

II 1GD Ex ia IIC T6 Ga Ex ia IIIC T85°C Da IP6x (Tamb - 40°C Gb to + 60°C)
Ex ia IIC T4 Ga Ex ia IIIC T135°C Da IP6x (Tamb - 40°C Gb to + 85°C)

INTEGRAL INCREASED SAFETY TERMINAL

Certificate No. BASEEFA03ATEX0089X
EN 60079-0:2006, EN 60079-7:2006

II 2G Ex e II T6

GLOBAL CERTIFICATION



CANADIAN STANDARDS ASSOCIATION
Snap switches for use in hazardous locations
Class 1, Groups A, B, C, D Class II, Groups E, F, G Division 1 and 2
LR67110-5

Dimensions

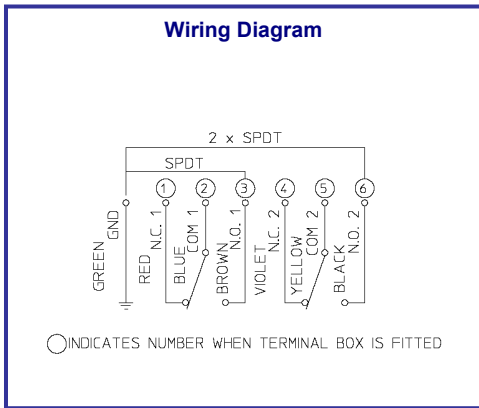

Dimensions

All dimensions in mm (Inches)

ENCLOSURES CODES W, A, H, R, 4 & 5 TABLE 1 WITH FLYING LEAD CODE A

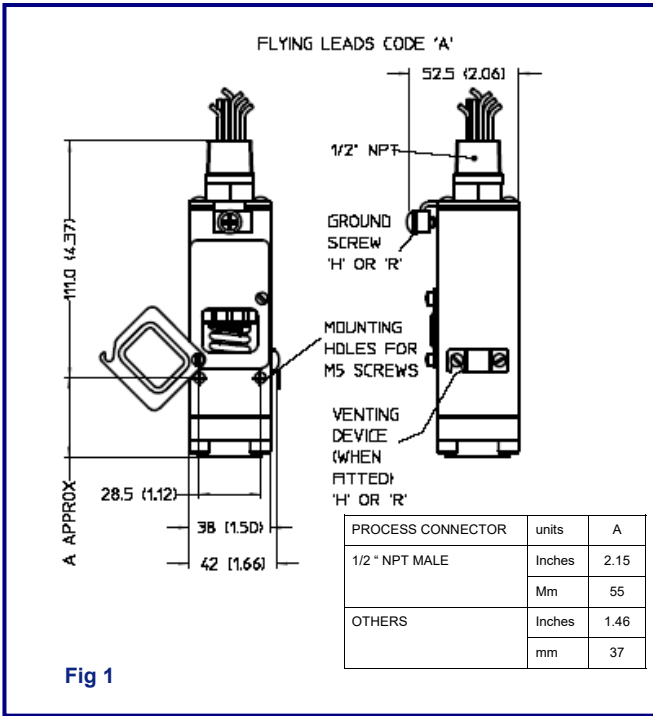

ENCLOSURES CODES W, A, H, R, 4 & 5 TABLE 1 WITH TERMINAL CODE C, D, V, W TABLE 3

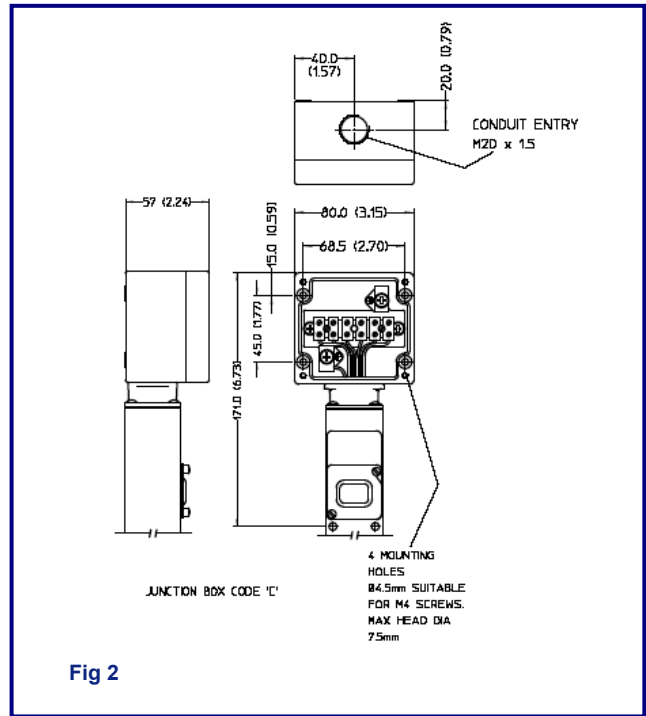

ENCLOSURES CODES H, R TABLE 1 WITH TERMINAL ENCLOSURE CODE J TABLE 3

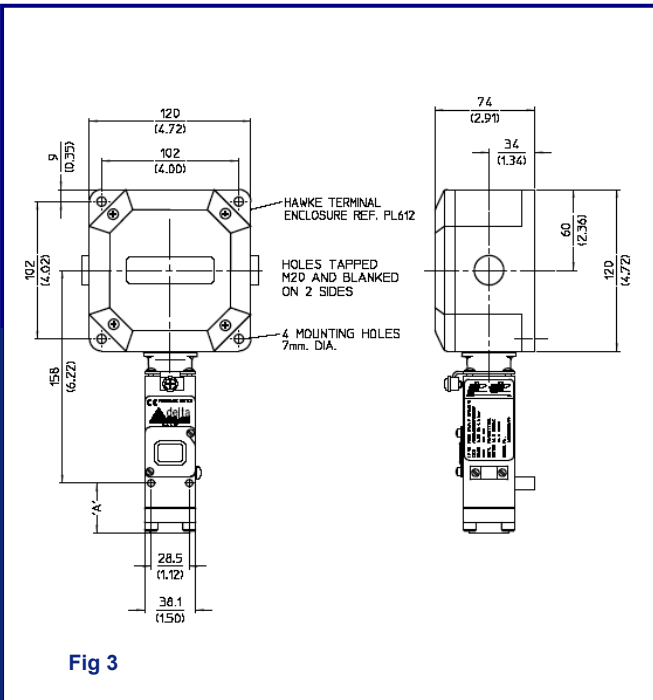

ENCLOSURES CODES H, R TABLE 1 WITH TERMINAL ENCLOSURE CODE K TABLE 3

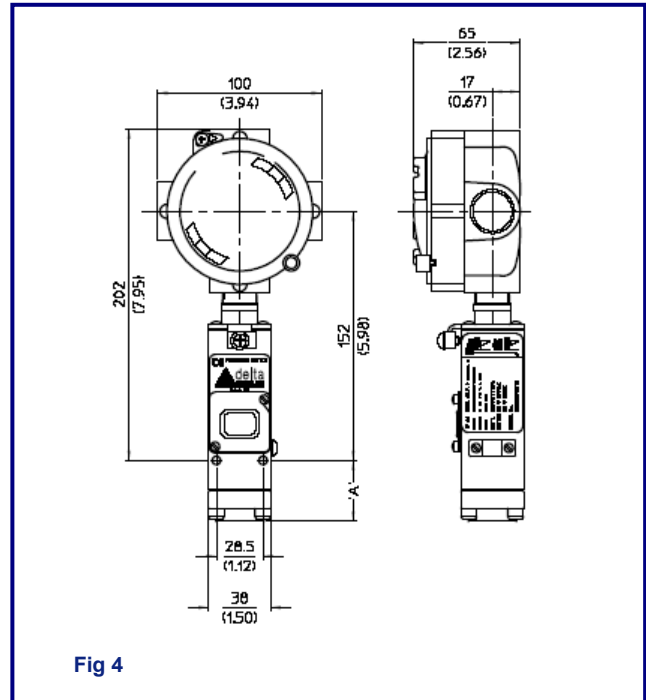

GR Series
Models: GR2 & GR4

In the interest of development and improvement Delta Mobrey Ltd, reserves the right to amend, without notice, details contained in this publication. No legal liability will be accepted by Delta Mobrey Ltd for any errors, omissions or amendments.

Delta Mobrey Limited
Hudson House, Albany Park Camberley Surrey, GU16 7PL, UK.
T+44 (0)1252 729140 F+44 (0)1252 729168 E sales@delta-mobrey.com W www.delta-mobrey.com



ISO9001

FM00720