

GENERAL CHARACTERISTICS

Mechanical Flow Indicator for liquids for quantitative flow indication. The rotor, which is arranged in a dome for good visibility, provides a directly flow- proportional indication of the actual flow rate. Rugged design in bronze/brass

- * good rotor sight
- * dome-shaped

Female thread G1/4 to G1 bronze



RL-010GR

TECHNICAL DATA

	G	Type	PN bar	Qmax. recom. l/min H ₂ O	start of rotor l/min H ₂ O	L mm	B mm	X mm	weight kg
bronze	G 1/4	RL-008GR	6	3.3	0.5	76	52	12	0.55
	G 3/8	RL-010GR	6	7.5	0.8	76	52	12	0.50
	G 1/2	RL-015GR	6	10.0	1.0	76	55	12	0.55
	G 3/4	RL-020GR	6	26.5	2.0	83	57	14	0.65
	G 1	RL-025GR	6	26.5	5.0	89	67	18	1.10

media temperature max. 100°C
average pressure loss 0.05 bar at Qmax.

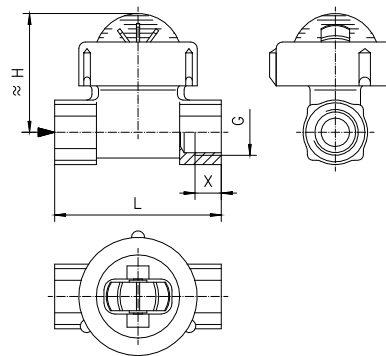

MATERIALS

body	bronze
ring	brass
dome	soda-lime glass
shaft	stainless steel
rotor	nylon
seal	NBR

MOUNTING POSITION

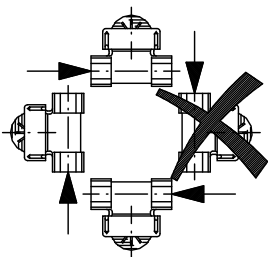

NOMENCLATURE

RL-	008	G	R	basic type specification	
	008		●	nominal diameter	DN 8 - G1/4
	010		●		DN 10 - G3/8
	015		●		DN 15 - G1/2
	020		●		DN 20 - G3/4
	025		●		DN 25 - G1
		G	●		female thread
			R	●	bronze

METERING SUBSTANCES



With higher viscosity instruments tend to higher starting values for rotor.

All technical changes reserved

IBASIC Standard ○BASIC Programme option □VARIO Special option ⊕ PLUS Accessories

X not recommendable