

Pneumatic Positioners 7400 Series

a sensitive, stable force balance system
for standard or non-standard valves

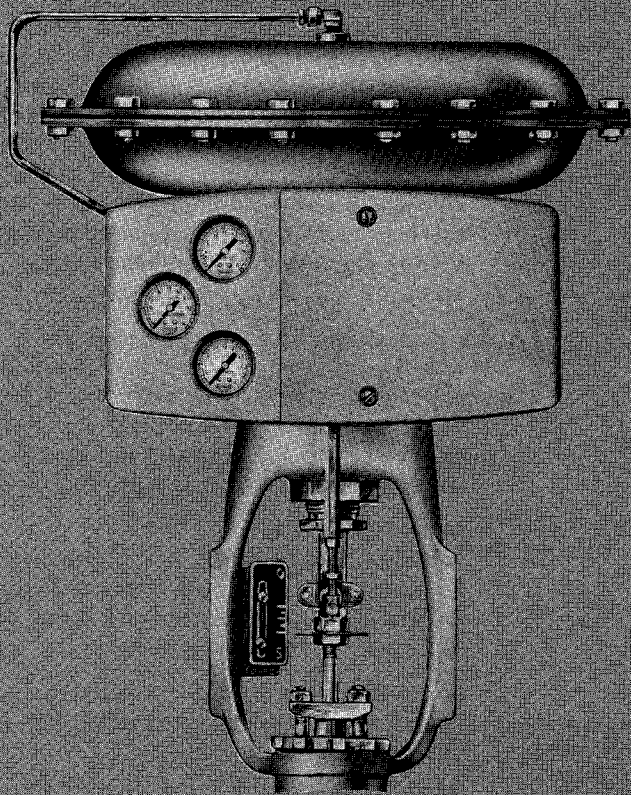

Masoneilan

DRESSER

Table of Contents

Numbering System	3
General Data	3
Operation	4
Motion Transmitter	5
Materials	5, 6
Dimensions	7
Mounting Orientation	8

Foreword

The primary function of the Masoneilan 7400 Series valve positioners is to insure that the control valve plug position is always directly proportional to the value of the controller output pressure, regardless of packing box friction, diaphragm actuator hysteresis or off-balance forces on the valve plug. These positioners also provide a convenient and accurate means of changing the effective output signal range of a controller and/or changing the valve action. With modifications, a 7400 Series positioner may be converted into a pneumatic transmitter of valve stem travel or other motion (Model 1400).

- **responsive to small pressure changes**
When complicated process lags necessitate the use of wide controller proportional band, the positioner provides an exact means of making the control valve responsive to very small changes in controller output pressure.
- **remote valve location**
When air-operated control valves are located far from the control instrument, positioners will reduce lag, thus speeding up valve operation response.
- **operates any standard or non-standard valve**
The positioner may be supplied to operate any valve, whether with standard, or non-standard springs, and for a number of signal ranges.

- **bypass valve is standard**
With the bypass set at "Positioner", the controller signal pressure is carried directly to the bellows and the supply is brought to the pilot for normal operation. When set at "Bypass" the positioner air supply is dead-ended and the controller signal pressure goes directly to the control valve. Maintenance can be performed on the positioner without disturbing the process.

- **split range**
Some processes require the sequential operation of two or three control valves by a single controller with a 3-15 psi output signal range. Where this occurs, each positioner-equipped valve is operated through its full spring range by a selected portion of the controller output signal range. The 7400 Series is very versatile and, through an adjustment, may be double or triple split.

- **standard, reduced, high capacity pilots**
The simple, sensitive pilot of the three-way valve type has sufficient capacity to operate the control valve at required speed and uses relatively little air. Pilots are available for standard, reduced or high capacity.

The following pages provide the necessary technical information required to specify the 7400 Series Positioner. For additional information, contact your local Masoneilan Representative.

Numbering System

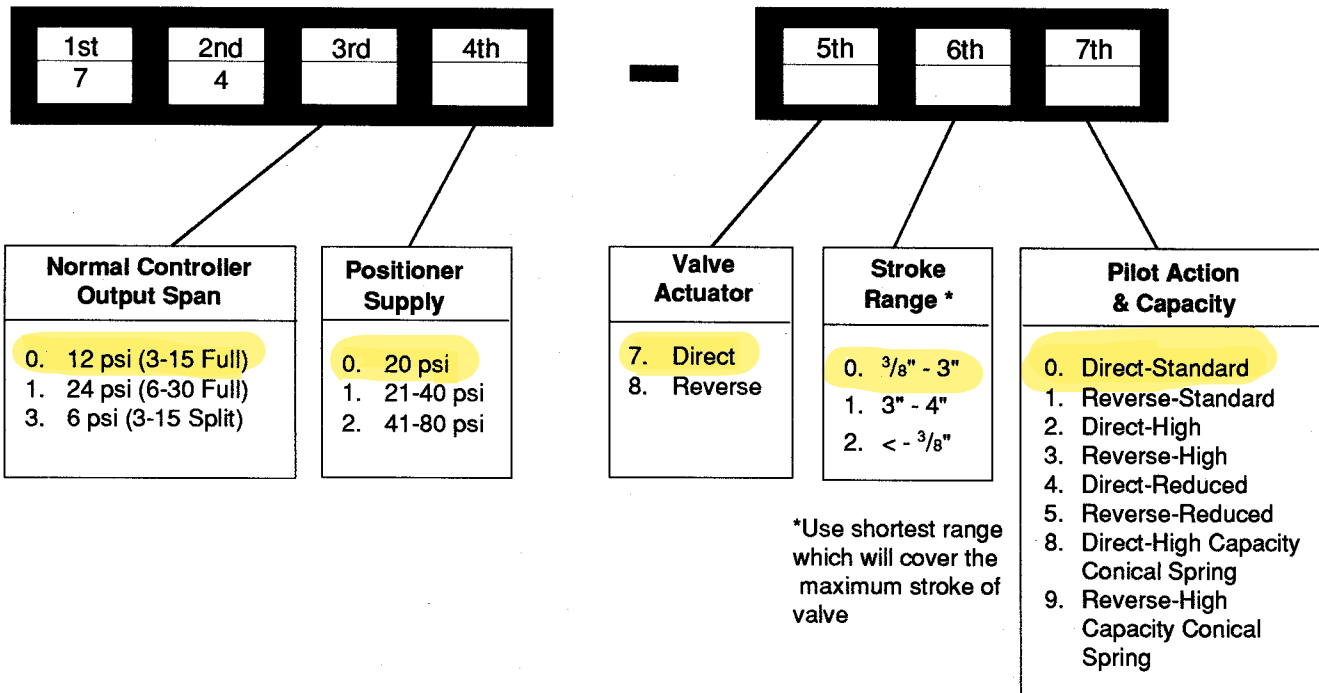

General Data

instrument signals

- standard:** 3-15 psi and 6-30 psi
- split range:** 6 psi (3-15 split)
- maximum positioner output:** 20, 40 and 80 psi
- stroke ranges:** $\frac{3}{8}$ "-3" and 3"-4"

action

- direct pilot:** increasing signal increases output pressure
- reverse pilot:** increasing signal decreases output pressure
- accuracy:** 0.2% of valve stroke

air consumption (max.)

- standard pilot:** (3-15) 0.4 scfm
(6-30) 0.56 scfm
- high capacity pilot:** (3-15) 0.6 scfm
(6-30) 0.84 scfm

In determining compressor capacity double the above consumption figures to allow for line leakage and condensate blowdown.

valve stroking time*

Actuator Size	Valve Stroke (in.)	Stroking Time (seconds)
9	$\frac{1}{2}$	2.5
	$\frac{3}{4}$	4.0
11	$\frac{3}{4}$	5.5
	1	7.0
13	1	11
	$1\frac{1}{2}$	13

Actuator Size	Valve Stroke (in.)	Stroking Time (seconds)
15	$1\frac{1}{2}$	17
	2	20
18	2	30
	$2\frac{1}{2}$	34
18L	$3\frac{1}{2}$	44
	4	48
24	4	82

Note: Increase stroking time by 15% for 6-30 psi spring range.

* Figures refer to direct spring-diaphragm actuators and the time to extend shaft, based upon 3-15 psi signal, 20 psi supply and a standard pilot size. Shorter times are achieved with high capacity pilot or with boosters.

Operation

The force balance system employed provides a linear relationship between valve position and controller output signal by converting stroke (a length) and force (pressure on a given area) to a common proportionality. The linear relationship is obtained by the comparison of the force derived from the controller output signal operating on the bellows and that derived from the effect of the valve stem movement on the force balance spring. The resultant movement on the force balance spring. The resultant of these two forces, as interpreted by a "beam balance" lever, throttles the pilot to maintain the proportionality.

With the bypass set for "Positioner," the controller output pressure is applied to the bellows. When this pressure is increased, the bellows rotates the bellcrank lever on a frictionless flexure bearing, causing the pilot to increase the positioner output pressure (direct action pilot) or to decrease output pressure (reverse action pilot). The resultant valve stem motion is transmitted through the takeoff linkage and positioner levers to the force balance spring, loading or unloading it until the spring tension on the bellcrank lever balances the opposing force of the bellows. When these two forces are in balance, the system is in equilibrium, with the pilot throttling the output pressure to maintain equilibrium as the controller signal changes.

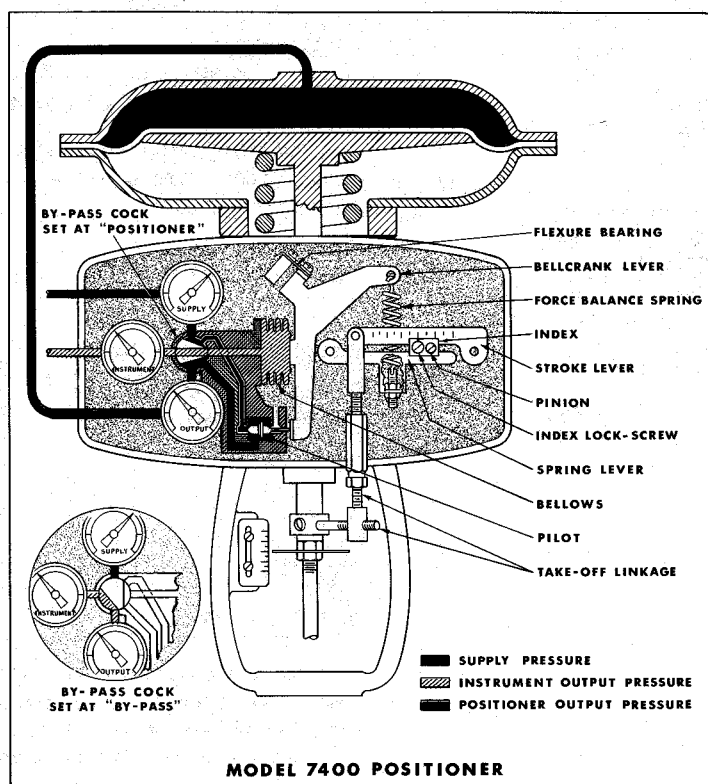

Motion Transmitter

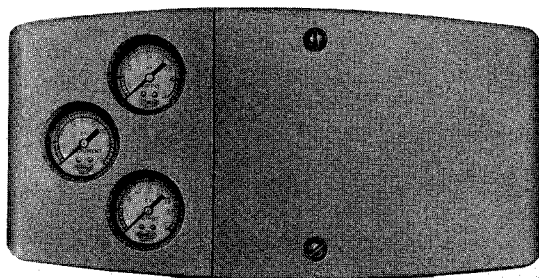

Model 7400
with gauges and bypass valve
mounted within positioner case.

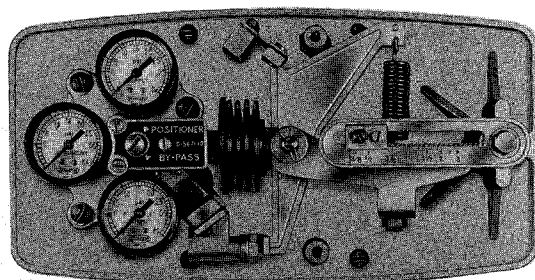

Positioner with case cover removed

Series 1400 Motion Transmitter

By modifying the porting of the air manifold and using a reverse action pilot, it is possible to convert a 7400 Series positioner to a pneumatic motion transmitter. The output pressure from the transmitter then becomes directly proportional to valve stem position. The motion transmitter is illustrated below. A reduced capacity reverse action pilot is used and a restriction is placed in the bellows inlet to obtain stability in the feedback action.

With different back lever lengths, it is possible to transmit motions from $\frac{3}{8}$ " to 4" and to convert them to a proportional 3-15 psi output pressure. The motion transmitter can be used on any application where there is sufficient positioning force available to overcome the force developed by the force balance spring. A graph of the maximum force to actuate the transmitter for the various strokes is below. (This force is the same as required to actuate the Series 7400 positioner with standard force balance spring.)

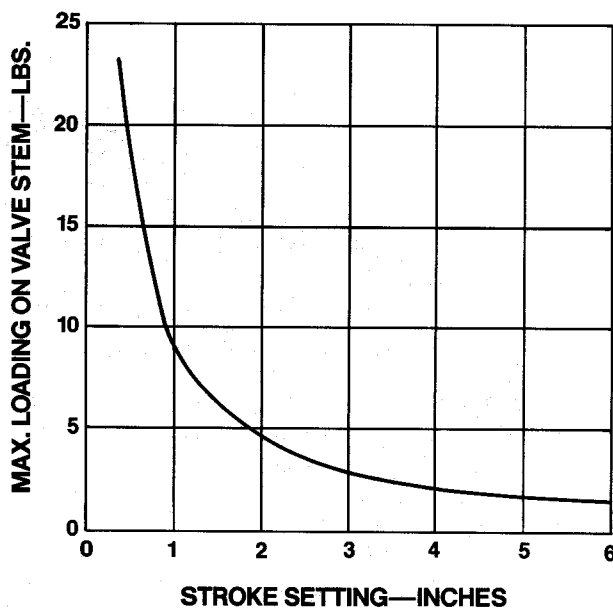
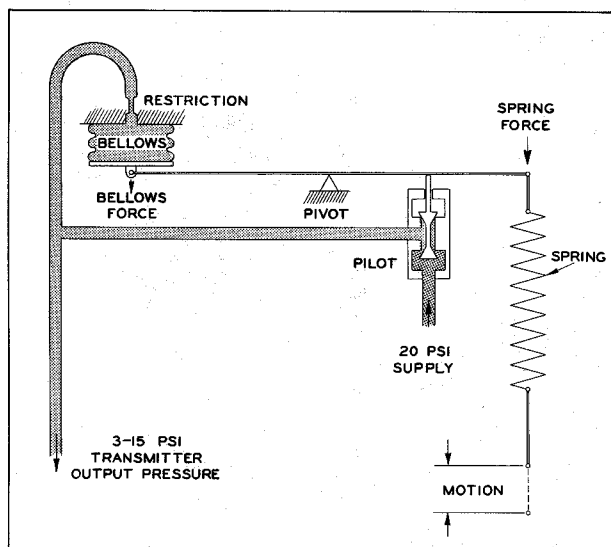

Materials

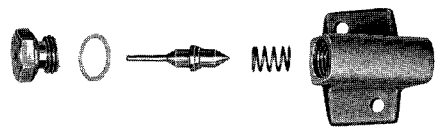
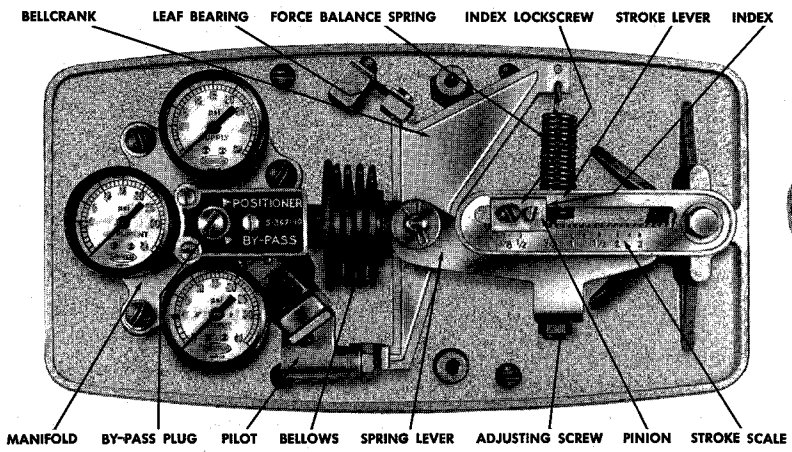

Exploded view of pilot
(Note minimum of parts)

Model 7400 Positioner with Case Cover Removed

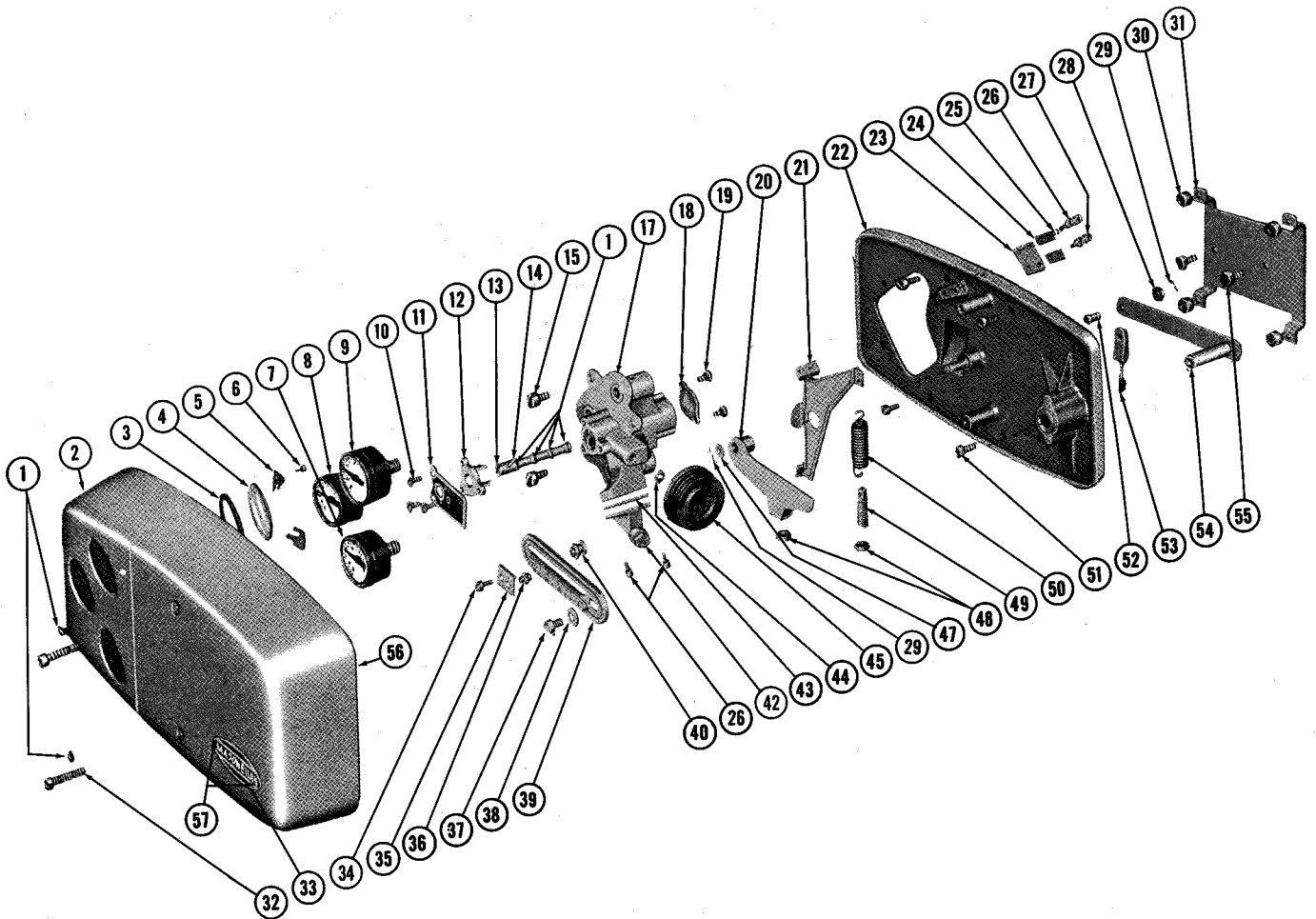

Materials

Ref. No.	Description
1	O Ring(s)
2	Cover
3	Gasket (Gauge Glass)
4	Gauge Glass
5	Clip (2 per Gauge Glass)
6	Machine Screw (1 for each clip)
7	Output Gauge
8	Instrument Gauge
9	Supply Gauge
10	Machine Screw
11	By-pass Plate
12	Cam
13	By-pass Plug
14	Groove Pin
15	Machine Screw (Mfd. to Back Plate Mtg.)
17	Manifold Assembly (includes 4 of Ref. 1 & Refs. 10, 11, 12, 13, 14, 18 & 19)
18	Cover Plate
19	Machine Screw (Cover Plate)
20	Spring Lever
21	Bell Crank
22	Back Plate
23	Leaf Bearing
24	Bearing Plate (Leaf)
26	Machine Screw (LEF BFG & PILOT Mtg.)
27	Machine Screw (LEF BRG & PILOT to Bell Crank Mtg.)

Ref. No.	Description
28	Washer (Clevis Pin)
29	Retainer Clip (1 each holds Refs. 28 & 52)
30	Spacer
31	Mounting Bracket
32	Cover Screw
33	Emblem
34	Machine Screw (Index Lock Screw)
35	Index
36	Pinion
37	Cap Screw (Stroke Lever to Back Lever)
38	Washer
39	Stroke Lever
40	Spool (Stroke Adjuster)
42	Pilot S/A
43	Pilot Gasket
44	Gasket (Bellows)
45	Bellows
47	Washer (Spring Lever)
48	Locknut (Adjusting Screw)
49	Adjusting Screw
50	Force Balance Spring
51	Machine Screw (BPL to MTG BKT)
52	Clevis Pin
53	Clevis
54	Back Lever
55	Cap Screw (Yoke Mounting)
56	Serial Plate (See Inside Cover)
57	Drive Screw (For Emblem & Serial Plates)

Dimensions

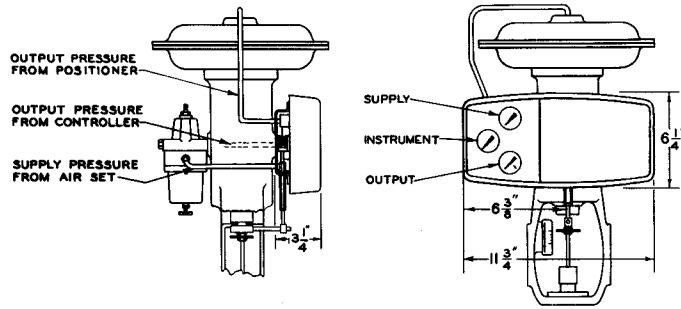

Mounting Orientations

Direct Pilot Positioner Mounting

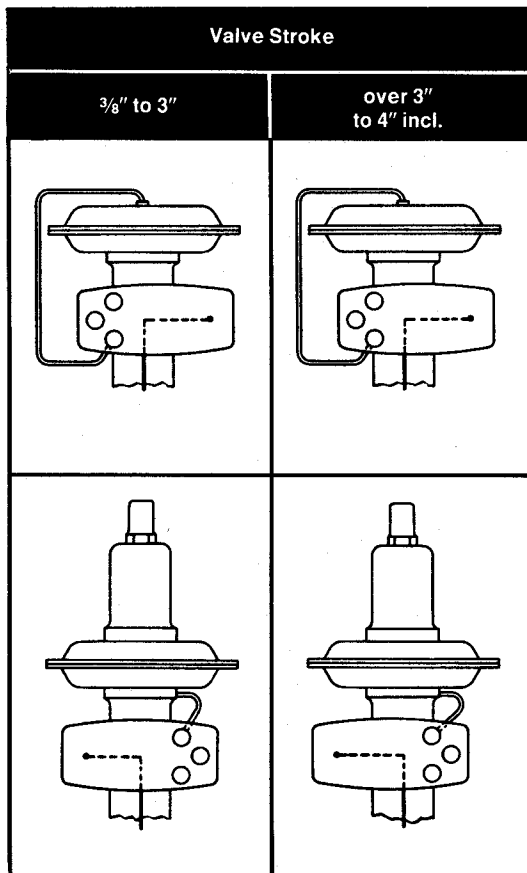

Reverse Pilot Positioner Mounting

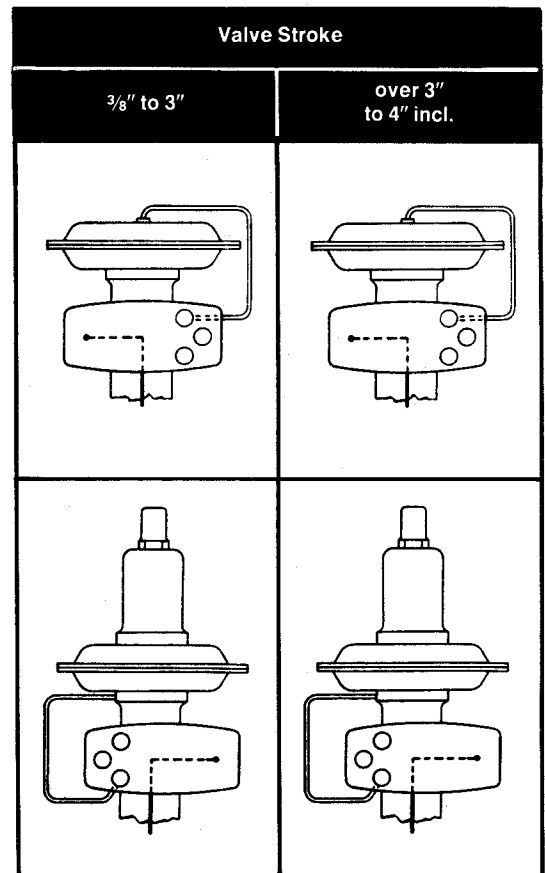

Facilities: Brazil, Canada, France, Germany, Italy, Japan, Mexico, Netherlands, Singapore, Spain, United Kingdom, United States



Masoneilan North American Operations
Dresser Valve and Controls Division
Dresser Industries, Inc.
Marketing Services
15112 Morales Road
P.O. Box 60078 (77205-0078)
Houston, Texas 77032
Tel: (713) 986-6500 Fax: (713) 986-6569