

# Series 5.02

## Technical Data Sheet

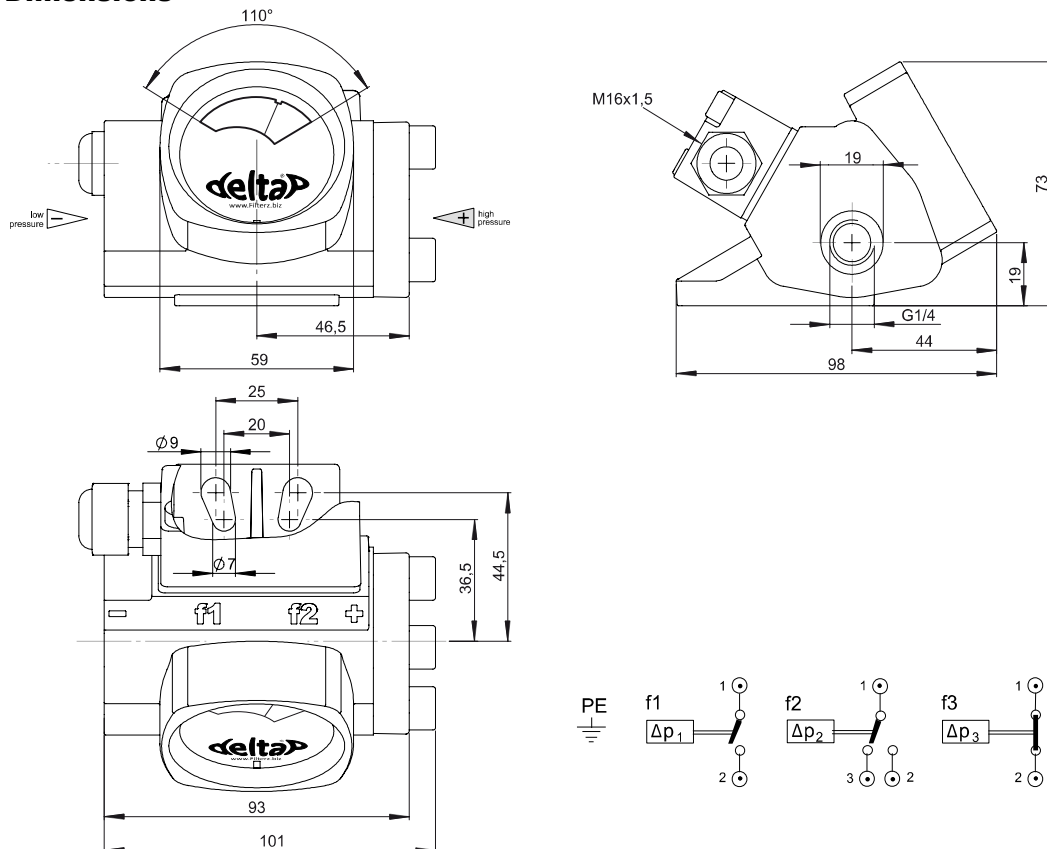

### Dimensions



### Use

Differential pressure indicators serve to monitor a variable pressure difference. They can be used with fuels, lubricating oils, hydraulic oils, emulsions and water, for example.

### Method of operation

A hermetically sealed piston moves with increasing pressure difference against the effect of a calibrated measuring element.

The piston position corresponding with the respective differential pressure is permanently magnetically transferred to the indicator disk at a rotation angle analogue to the differential pressure. This analogically indicates the increasing differential pressure from blue=Differential pressure 0 bar to red=Differential pressure maximum.

In addition, electrical signals can be generated at up to two switching points within the indication range. NO contacts, NC contacts and changeover contacts are available for this purpose.

### Technical data

perm. operating overpressure	100 bar
perm. operating temperature	Medium: max. 120°C
Environmental / housing temperature:	max. 120°C (dep. on attachment parts)
Cable gland:	max. 100°C
Basic measuring range Standard:	beginning at 0 to $\Delta p_{max}$ = 0.3 – 0.5 – 0.6 – 0.7 – 0.8 – 1.0 1.2 – 1.3 – 1.5 – 1.6 – 2.0 – 2.5 – 3.0 – 3.5 – 4.2 bar
Measuring range extension (high pressure attachment):	Pressure transmission of the entire measuring range; possible factors: x 2.0 / x 3.0 / x 4.0

deltaP® Differential Pressure Indicator

This data sheet must not be used for competition purposes or out of self-interest or made accessible to third parties (Act Against Unfair Practices UWG § 5, 17-21). All rights for granting of patent or registration of a utility model reserved (6-12 Patent Act PatG). We reserve the right to change this description without notice. Subject to technical modifications. All copyrights belong to FRIEDRICH'S FILTERS/STEME GMBH Lothforster Benden 2, 41849 Wassenberg



# Series 5.02

## Technical Data Sheet



### Technical data (continuation)

Optical signalling:	V-shaped 110° (0.1...1.0 x $\Delta p_{max}$ ) via rotating indicator disk blue (clean) / red (contaminated)
Installation position:	any
Electrical signalling:	Can be equipped with 0 / 1 / 2 contacts Type f1: NO contact (standard switchpoint at 0.75x $\Delta p$ ) Type f2: Changeover contact (standard switchpoint at 1.0x $\Delta p$ ) Type f3: NC contact (standard switchpoint at 1.0x $\Delta p$ ) Other switchpoints on request
Switching accuracy:	$\pm 0.05$ bar ( $\Delta p_{max} \leq 2.0$ bar); $\pm 0.08$ bar ( $\Delta p_{max} > 2.0$ bar)
Switching capacity:	Contact type f1: 120W / 250 V / 3.0 A / 120 VA Contact type f2: 30W / 250 V / 1.0 A / 60 VA Contact type f3: 30W / 250 V / 1.0 A / 60 VA

### Materials (standard design)

Housing:	GK-AlSi 10 (Mg) hart-coated
Pistons:	Ms 58 (exposed to medium)
Measuring element:	1.4310 (CrNi Steel) (exposed to medium)
Screws:	Stainless steel (VA)
Seal (roll membrane):	NBR
Cable gland:	PA (polyamide); seal: CR (chloroprene rubber)

### Connections

Fixture:	2x universal slot, spacing 20mm / 25mm to fit M6 / M8 hexagon socket screws
Fluid connections:	internal thread both sides G1/4 , suitable screw joints DIN 2353
Switch contacts (standard):	Terminal strip with cover cap and cable gland (Clamping range 4.5...10mm) Suitable for connection cables max. 1.5mm <sup>2</sup> , stripping length $\leq 8$ mm Optionally: div. plug connectors, see type code

### Viewing glass alignment

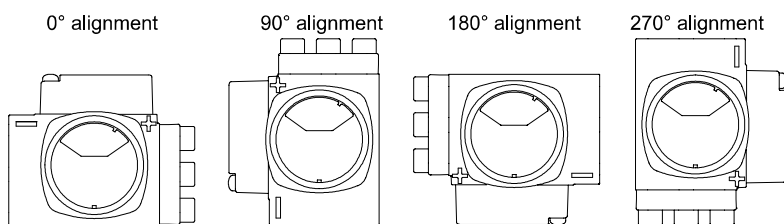

### Schematic diagram

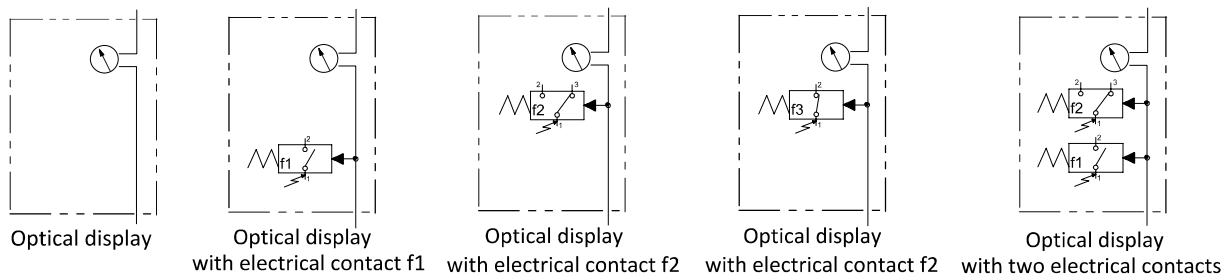

deltaP® Differential Pressure Indicator

This data sheet must not be used for competition purposes or out of self-interest or made accessible to third parties (Act Against Unfair Practices UWG § 5, 17-21). All rights for granting of patent or registration of a utility model reserved (6-12 Patent Act PatG). We reserve the right to change this description without notice. Subject to technical modifications. All copyrights belong to FRIEDRICHS FILTERSYSTEME GMBH Lothforster Benden 2, 41849 Wassenberg



# Series 5.02

## Technical Data Sheet



### Type code

<b>DP 5.02-2.0 (2.0=Δp measuring range)</b>	Basic device without electrical contacts
includes:	Spring made of 1.4310
	Piston made of Ms 58
	Roll membrane NBR
	Viewing glass with lettering "deltaP®"

<b>DP 5.02</b>	<b>-</b>	<b>2.0</b>	<b>-</b>	<b>.T</b>	<b>-</b>	<b>f1.1.4</b>	<b>-</b>	<b>f2.2.0</b>	<b>-</b>	<b>V</b>	<b>-</b>	<b>VA</b>	<b>-</b>	<b>O</b>	<b>-</b>	<b>1</b>	<b>-</b>	<b>X</b>	<b>-</b>	<b>N</b>
Viewing glass lettering (Standard deltaP®)																				
N Neutral																				
S Special design acc. to customer specification																				
Viewing glass alignment (Standard 0° see Page 2)																				
X 90°																				
Y 180°																				
Z 270°																				
Electr. connection/connector (if with contact(s) standard terminal strip)																				
1 1x DIN 43650connector																				
2 2x DIN 43650connector																				
3 1x circular connector M12 4-																				
4 2x circular connector M12 4-																				
5 1x Han-7D connector																				
Piston design (standard roll membrane)																				
O for O-ring																				
HD for high-pressure attachment																				
P with Kotef seal (PTFE ring)																				
Piston material (standard Ms 58)																				
VA 1.4435 (CrNi-Steel)																				
Seal material (standard NBR)																				
V FPM (fluorine-polymer rubber)																				
E EPDM (ethylene-propylene rubber)																				
Changeover contact f2/NC contact f3																				
f2.X.X Switchpoint in bar (standard: 100% Δp max.)																				
f3.X.X Switchpoint in bar (standard: 100% Δp max.)																				
other switchpoints on request																				
NO contact f1																				
f1.X.X Switchpoint in bar /standard 75% Δp max.)																				
other switchpoints on request																				
Measuring element																				
X.X.T Add. T for PTFE coated																				
Measuring range																				
X.X Δp max. see page 1																				
Series																				
DP 5.02 deltaP® differential pressure indicator type 5.02																				

deltaP® Differential Pressure Indicator

This data sheet must not be used for competition purposes or out of self-interest or made accessible to third parties (Act Against Unfair Practices UWG § 5, 17-21), All rights for granting of patent or registration of a utility model reserved (6 - 12 Patent Act PatG). We reserve the right to change this description without notice. Subject to technical modifications. All copyrights belong to FRIEDRICHS FILTERSYSTEME GMBH Lothforster Benden 2, 41849 Wassenberg

