

Emerson™ Wireless 775THUM™ Adapter



WirelessHART IEC CE

Safety information

NOTICE

Read this manual before working with the product. For personal and system safety, and for optimum product performance, make sure to thoroughly understand the contents before installing, using, or maintaining this product. The United States has two toll-free assistance numbers and one international number.

Customer Central

800 999 9307 (7:00 a.m. to 7:00 p.m. CST)

North American Response Center

1-800-654-7768 (24 hours a day)

Equipment service needs.

International 1 952 906 8888

⚠ CAUTION

The products described in this document are NOT designed for nuclear-qualified applications.

Using non-nuclear qualified products in applications that require nuclear-qualified hardware or products may cause inaccurate readings.

For information on Rosemount nuclear-qualified products, contact an Emerson Sales Representative.

⚠ WARNING

Explosions could result in death or serious injury.

Installation of this transmitter in an explosive environment must be in accordance with the appropriate local, national, and international standards, codes, and practices. Review the Product Certifications section for any restrictions associated with a safe installation.

Before connecting a Field Communicator in an explosive atmosphere, ensure the instruments are installed in accordance with intrinsically safe or non-incendive field wiring practices.

Electrical shock can result in death or serious injury.

Avoid contact with the leads and terminals. High voltage that may be present on leads can cause electrical shock.

This device complies with Part 15 of the FCC Rules. Operation is subject to the following conditions. This device may not cause harmful interference. This device must accept any interference received, including interference that may cause undesired operation. This device must be installed to ensure a minimum antenna separation distance of 20 cm from all persons.

NOTICE

The THUM Adapter and all other wireless devices should be installed only after the Emerson Wireless Gateway has been installed and is functioning properly. Wireless devices should also be powered up in order of proximity from the Gateway, beginning with the closest. This will result in a simpler and faster network installation.

During normal operation, or in fault condition, the THUM Adapter will cause a 2.5 V drop in the connected loop. It is important to ensure that the power supply can provide at least 2.5 V more than the lift off voltage of the wired device to make sure it works properly with the THUM Adapter installed. To determine the lift off voltage for the wired device, review the wired device operation and installation manual.

Contents

Chapter 1	Introduction.....	5
	1.1 Using the Manual.....	5
	1.2 Features.....	5
	1.3 Considerations.....	6
Chapter 2	Configuration.....	9
	2.1 Safety messages.....	9
	2.2 Connections.....	9
	2.3 Configure device sensor.....	9
	2.4 Connection diagrams.....	10
	2.5 Device network configuration.....	11
	2.6 HART® menu tree.....	13
Chapter 3	Mounting.....	15
	3.1 Safety messages.....	15
	3.2 Direct mount.....	15
	3.3 Remote mount.....	16
	3.4 Power supply.....	17
	3.5 Load resistor.....	18
	3.6 Wiring diagrams.....	18
	3.7 Loop current test.....	33
Chapter 4	Commissioning.....	37
	4.1 Safety messages.....	37
	4.2 Device network configuration.....	37
	4.3 Network status.....	38
	4.4 Verify operation.....	39
Chapter 5	Operation and maintenance.....	41
	5.1 Safety messages.....	41
	5.2 Startup sequence.....	41
	5.3 Advanced setup.....	42
Chapter 6	Troubleshooting.....	45
	6.1 Overview.....	45
	6.2 Service support.....	47
Appendix A	Specifications and reference data.....	49
	A.1 Functional specifications.....	49
	A.2 Physical specifications.....	49
	A.3 Performance specifications.....	51
Appendix B	Dimensional Drawings.....	53
Appendix C	Product Certifications.....	55
	C.1 European Directive Information.....	55
	C.2 Ordinary location certification from FM Approvals.....	55

	C.3 Telecommunication compliance (for wireless products only).....	55
	C.4 FCC and IC (for wireless products only).....	55
	C.5 Installing equipment in North America.....	55
	C.6 USA.....	56
	C.7 Canada.....	56
	C.8 Europe.....	56
	C.9 International.....	57
	C.10 Brazil.....	57
	C.11 China.....	58
	C.12 Japan.....	58
	C.13 EAC - Belarus, Kazakhstan, Russia.....	58
	C.14 Republic of Korea.....	59
	C.15 India.....	59
	C.16 Combinations.....	59
Appendix D	Ordering Information.....	61
	D.1 Online product configurator.....	61
	D.2 Specifications and options.....	61
	D.3 Model codes.....	61
	D.4 Optimizing lead time.....	61
	D.5 Required model components.....	61
	D.6 Model.....	61
	D.7 Output.....	62
	D.8 Housing.....	62
	D.9 Mounting connection.....	62
	D.10 PlantWeb functionality.....	62
	D.11 Certification.....	63
	D.12 Wireless update rate, operating frequency, and protocol.....	63
	D.13 Omni-directional antenna and SmartPower™ solutions.....	63
	D.14 Accessories.....	63
Appendix E	Dimensional drawings.....	65

1 Introduction

1.1 Using the Manual

This manual is designed to assist in the installation, operation, and maintenance of the Emerson™ *Wireless 775 THUM™* Adapter.

Introduction

- Manual and transmitter overview
- Considerations

Configuration

- Device Sensor Configuration
- Device Network Configuration

Mounting

- Mount the Sensor
- Sensor Assembly/Leads
- Grounding

Commissioning

- Network Status
- Verify Operation

Operation and maintenance

- Startup Sequence
- Advanced Setup

Troubleshooting

- Troubleshooting recommended actions
- Service support

Specifications and reference data

- Specifications
- Dimensional Drawings
- Ordering Information

Product Certifications

- Product Certifications
- Installation Drawings

1.2 Features

- An installation-ready solution that provides rich wireless HART® data
- Works with any 2- or 4-wire HART devices
- Flexibility to meet your most demanding applications

- Wireless output with > 99 % data reliability delivers rich HART data, protected by industry leading security
- Gain access to additional HART information, such as diagnostics or multi-variable data
- Add wireless to almost any measurement point without affecting the approval of the sub-device
- IEC 62591 (WirelessHART®) capabilities extend the full benefits of Plantweb™ to previously inaccessible locations

1.3 Considerations

1.3.1 General consideration

The THUM™ Adapter is connected to a HART® sub-device. With simple HART configuration, the THUM transmits the HART information from the sub-device into the Wireless network.

1.3.2 Commissioning consideration

The THUM™ Adapter can be commissioned before or after installation. It may be useful to bench commission the THUM Adapter before installation to ensure proper operation and to become familiar with the functionality. The instruments should be installed in accordance with intrinsically safe or non-incendive field wiring practices, when required. The THUM Adapter is powered when connected to a powered loop.

1.3.3 Mechanical consideration

When choosing an installation location and position for the transmitter, take into account access to the device.

For best performance, the antenna should be vertical and have some space between objects in a parallel metal plane such as a pipe or metal framework, as the pipes or framework may adversely affect the performance of the antenna.

1.3.4 Electrical consideration

The THUM™ Adapter is connected into a powered 4–20 mA loop, powering itself by scavenging power.

The THUM Adapter causes a voltage drop across the loop. The drop is linear from 2.25 volts at 3.5 mA to 1.2 volts at 25 mA, but does not effect the 4–20 mA signal on the loop. Under fault conditions, the maximum voltage drop is 2.5 volts.

1.3.5 Environmental consideration

Verify that the operating environment of the transmitter is consistent with the appropriate hazardous locations certifications.

Table 1-1: Temperature Limits

Operating limit	Storage limit
-40 to 185 °F	-40 to 185 °F
-40 to 85 °C	-40 to 85 °C

1.3.6 Wireless considerations

Power up sequence

Power should not be applied to any wireless device until the Gateway is installed and functioning properly. Wireless devices should also be powered up in order of proximity from the Gateway, beginning with the closest. This will result in a simpler and faster network installation. Enable active advertising on the Gateway to ensure that new devices join the network faster. For more information see the [Emerson Wireless 1420 Gateway Reference Manual](#).

THUM™ Adapter position

If possible, the THUM Adapter should be positioned vertically, either straight up or straight down, and it should be approximately 3 ft. (1 m) from any large structure, building, or conductive surface to allow for clear communication to other devices. If the THUM Adapter is mounted horizontally, wireless communication range may be decreased.

Figure 1-1: THUM Adapter Position

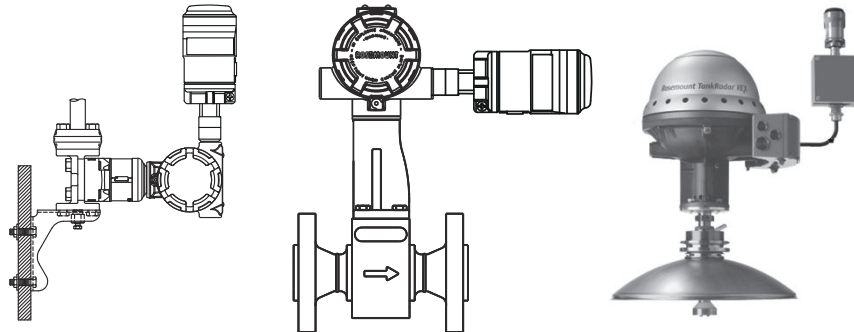

Conduit entry

When installing the THUM Adapter into the conduit entry of a wired device, use an approved thread sealant. Thread sealant provides a water tight seal and lubrication to ensure easy removal of the THUM Adapter.

M20 conduit adapter

When using the M20 Conduit Adapter on the THUM Adapter, use an approved thread sealant and tighten wrench tight to the THUM Adapter. When installing the M20 conduit adapter into a conduit, tighten to 32.5 Nm/25 ft-lb. to ensure water tight seal.

Field Communicator connections

In order for the Field Communicator to interface with the THUM Adapter, the wired device must be powered. The Field Communicator must be put into poll mode and should use the THUM Adapter address of 63.

Power supply

Minimum loop load of 250 Ohms.

The THUM Adapter communicates and derives power from a standard 4-20 mA/HART loop. The THUM Adapter causes a small voltage drop on the loop which is linear from 2.25 V at 3.5 mA to 1.2 V at 25 mA. Under fault conditions, the maximum voltage drop is 2.5 V. The THUM Adapter will not affect the 4–20 mA signal under normal or fault conditions as long as the loop has at least a 2.5 V margin at the maximum loop current (25 mA for a typical 4-20 mA/HART device).

Limit the power supply to 0.5 Amps maximum, and voltage to 30 Vdc.

Loop current	THUM Adapter voltage drop
3.5 mA	2.25 V
25 mA	1.2 V

Load resistor

If required, add a load resistor as shown in [Figure 3-6](#), [Figure 3-9](#), or [Figure 3-10](#). The resistor should be adequately rated for the application (1W minimum) and be compatible with the supplied splice connector which accepts wire sizes from 14 to 22 AWG.

When adding a load resistor, ensure that uninsulated conductors do not contact the enclosure and/or other exposed metal parts.

1.3.7 Product recycling/disposal

Recycling of equipment and packaging should be taken into consideration. The product and packaging should be disposed of in accordance with local and national legislation.

2 Configuration

2.1 Safety messages

Instructions and procedures in this section may require special precautions to ensure the safety of the personnel performing the operations. Information that potentially raises safety issues is indicated by a warning symbol () . Please refer to the following safety messages before performing an operation preceded by this symbol.

⚠ WARNING

Failure to follow these installation guidelines could result in death or serious injury.

Only qualified personnel should perform the installation

Explosions could result in death or serious injury.

Before connecting a field communicator in an explosive atmosphere, make sure that the instruments are installed in accordance with intrinsically safe or non-incendive field wiring practices.

Verify that the operating atmosphere of the transmitter is consistent with the appropriate hazardous locations certifications.

Electrical shock could cause death or serious injury.

Use extreme caution when making contact with the leads and terminals

This device complies with Part 15 of the FCC Rules. Operation is subject to the following conditions: This device may not cause harmful interference. This device must accept any interference received, including interference that may cause undesired operation. This device must be installed to ensure a minimum antenna separation distance of 20 cm from all persons.

2.2 Connections

Section 2 details wiring the Emerson Wireless THUM Adapter to the different types of compatible sub-devices.

2.3 Configure device sensor

The THUM™ Adapter, attached to a powered sub-device, receives HART® Communication from a Field Communicator or AMS Device Manager.

Configure device sensor using Field Communicator

In order to communicate with the THUM Adapter, polling must be activated on the Field Communicator. The default address for the THUM Adapter is 63. Also, note that any configuration changes must be sent to the transmitter using the Send key (F2).

Configure device sensor using AMS Wireless Configurator

AMS Wireless Configurator is capable of connecting devices directly using a HART modem or the Gateway. For configuring through AMS Wireless Configurator, double-click the device icon and select the **Configure/Setup** tab. AMS Configuration changes are implemented when the **Apply** button is selected.

2.4 Connection diagrams

Bench hook-up

Connect the bench equipment as shown in either [Figure 2-1](#) and [Figure 2-2](#), and turn on the field communicator by pressing the ON/OFF key or log into AMS Device Manager. The Field Communicator or AMS Device Manager will search for a HART-compatible device and indicate when the connection is made. If the Field Communicator or AMS Device Manager fail to connect, it indicates that no device was found. If this occurs, refer to [Commissioning](#).

Field hook-up

Field hook-up requirements are detailed in [Figure 2-1](#) and [Figure 2-2](#).

Figure 2-1: THUM Adapter Only, Powered by a Current Source

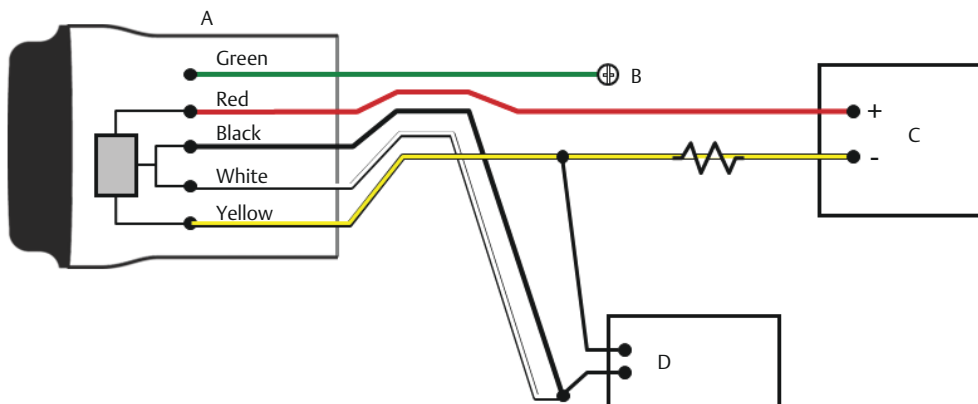

- A. THUM Adapter
- B. Ground
- C. 20 mA current source
- D. HART modem

Figure 2-2: THUM Adapter Only, Powered by a 24 V Power Supply with 1200 Ohm Resistor to Limit Current to 20 mA

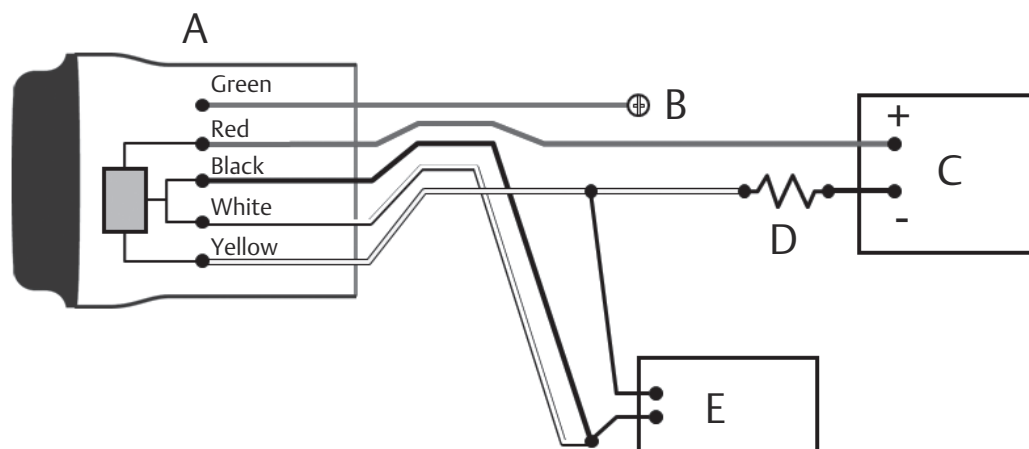

- A. THUM Adapter
- B. Ground
- C. 24 V power supply
- D. 1200 ohm resistor
- E. HART modem

The 1200 Ohm resistor should be adequately rated for the application (3 W minimum).

2.5 Device network configuration

2.5.1 Join device to network

In order to communicate with the Emerson Wireless Gateway, and ultimately the Host System, the Emerson THUM™ Adapter must be configured to communicate over the wireless network. This step is the wireless equivalent of connecting wires from a transmitter to the host system.

Fast Keys	2, 1,1
------------------	--------

Procedure

1. From the Home screen, select **2: Configure**.
2. Select **1: Guided Setup**.
3. Select **1: Join Device to Network**.

2.5.2 Configure update rate

The Update Rate is the frequency at which a new measurement is taken and transmitted over the wireless network. This by default is one minute. This may be changed at commissioning, or at any time via AMS Wireless Configurator. The Update Rate is user selectable from eight seconds to 60 minutes.

Fast Keys	2, 1, 2
------------------	---------

Procedure

1. From the Home screen, select **2: Configure**.
2. Select **1: Guided Setup**.
3. Select **2: Configure Update Rate**.

2.5.3 Configure THUM™ Adapter long tag

The Long Tag is how the THUM Adapter will show up in the Gateway web interface. By setting this parameter to a unique value, it will be easier to determine with which THUM Adapter you are communicating. To do this, use the tag number of the wired device that the THUM adapter is connected to followed by THUM (HARTTAG-THUM).

Fast Keys	2, 2, 4, 2
------------------	------------

Procedure

1. From the *Home* screen, select **2: Configure**.
2. Select **1: Manual Setup**.
3. Select **2: Device Information tab**.
4. Enter the Long Tag.

2.5.4 Wired device tag

For HART® 5 devices, the THUM™ Adapter uses the message field when reporting the HART tag to the Gateway. To ensure that you can identify the wired device in the Gateway make sure to write the tag information into the message field for all HART 5 devices. For HART 6 or newer devices the THUM Adapter reports the long tag as the HART tag to the Gateway.

2.6 HART® menu tree

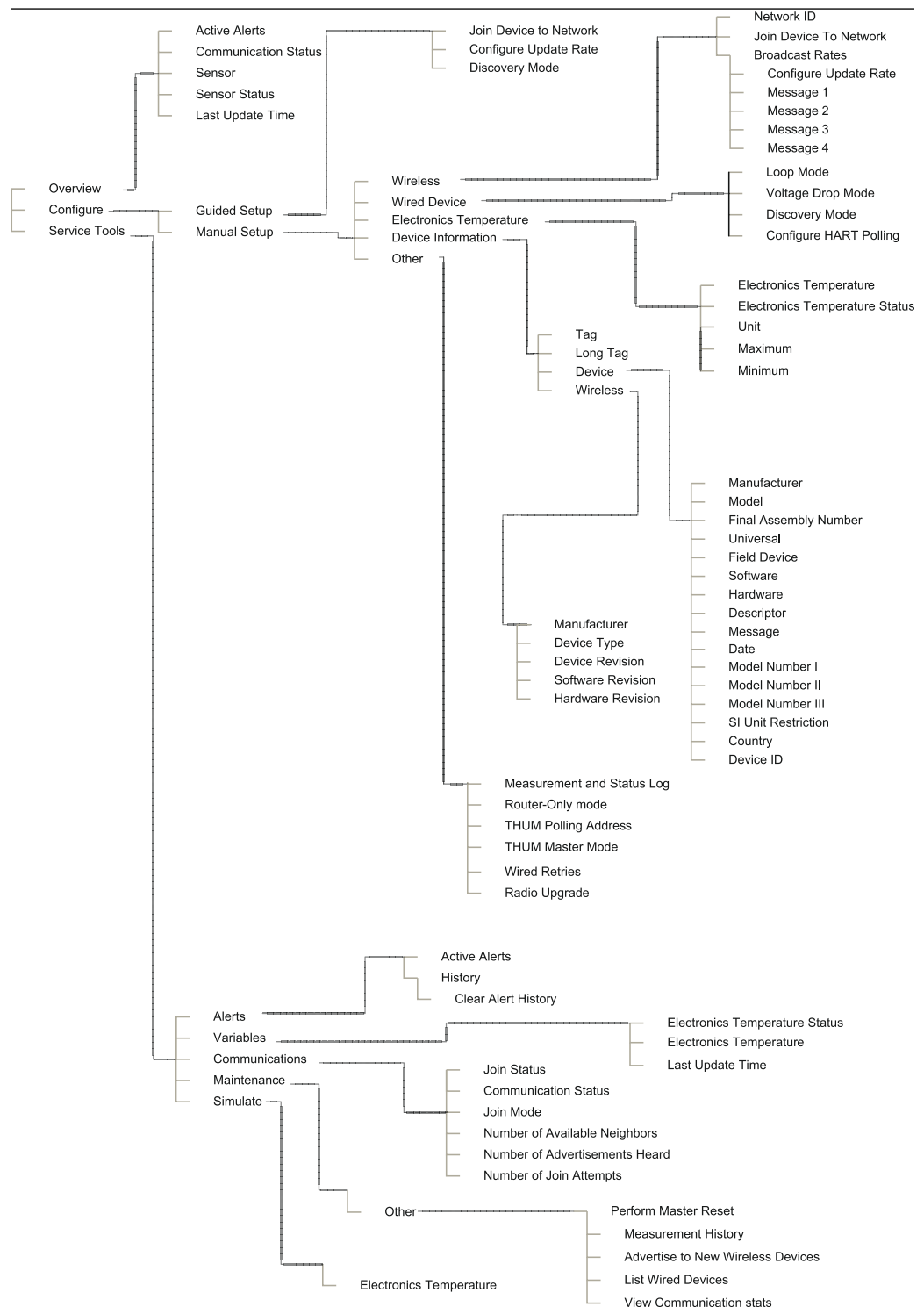

3 Mounting

3.1 Safety messages

Instructions and procedures in this section may require special precautions to ensure the safety of the personnel performing the operations. Information that potentially raises safety issues is indicated by a warning symbol () . Please refer to the following safety messages before performing an operation preceded by this symbol.

⚠ WARNING

Failure to follow these installation guidelines could result in death or serious injury.

Only qualified personnel should perform the installation

Explosions could result in death or serious injury.

Before connecting a field communicator in an explosive atmosphere, make sure that the instruments are installed in accordance with intrinsically safe or non-incendive field wiring practices

Verify that the operating atmosphere of the transmitter is consistent with the appropriate hazardous locations certifications

Electrical shock could cause death or serious injury.

Use extreme caution when making contact with the leads and terminals

This device complies with Part 15 of the FCC Rules. Operation is subject to the following conditions: This device may not cause harmful interference. This device must accept any interference received, including interference that may cause undesired operation.

This device must be installed to ensure a minimum antenna separation distance of 20 cm from all persons.

3.2 Direct mount

Prerequisites

Install the HART device according to standard installation practices and the manufacturer's instructions. Use an approved thread sealant on all connections.

Procedure

1. Attach the THUM Adapter to the wired device as shown in [Figure 3-1](#).

Figure 3-1: Direct Mount

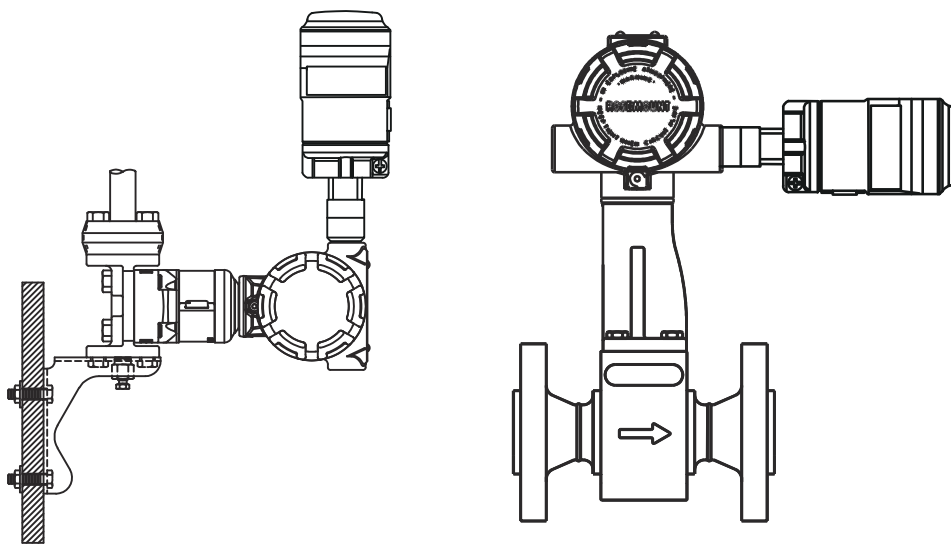

2. Connect the THUM Adapter to the HART wired device using the [Wiring diagrams](#).
3. Close the housing cover on the HART wired device, so that metal touches metal, but do not overtighten to prevent damaging the unit.

Note

Two splice connectors are included with the THUM Adapter. The first is a two connection splice. The second is a three connection splice for use with a resistor, if there is not enough resistance in the loop. Both of these splice connectors can accept 14 to 22 gauge wire. See wired device reference manual for information on the required loop resistance.

3.3 Remote mount

Prerequisites

Install the HART device according to standard installation practices and the manufacturer's instructions. Use an approved thread sealant on all connections.

Procedure

1. The THUM Adapter should be mounted as shown in [Figure 3-2](#).

Figure 3-2: Remote Mount

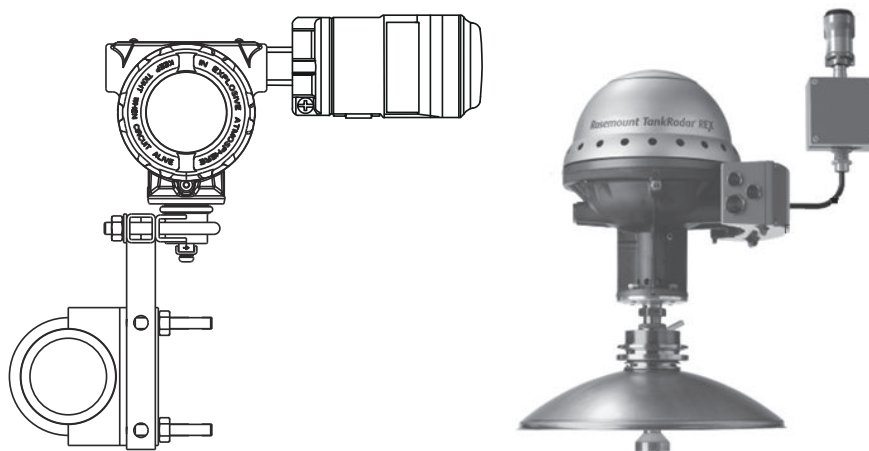

2. Ground the Remote Mount Kit per local practices.
3. Connect the THUM Adapter to the wired device using standard practices. Wire running from the THUM Adapter to the wired device should be shielded or in conduit when installed in electrically noisy environments.
4. Connect the THUM Adapter to the HART wired device using the [Wiring diagrams](#).
5. Close the housing cover on the HART wired device, so that metal touches metal, but do not overtighten to prevent damaging the unit.

Note

Two splice connectors are included with the THUM Adapter. The first is a two connection splice. The second is a three connection splice for use with a resistor, if there is not enough resistance in the loop. Both of these splice connectors can accept 14 to 22 gauge wire. See wired device reference manual for information on the required loop resistance.

3.4 Power supply

Minimum loop load of 250 Ohms.

The THUM Adapter communicates and derives power from a standard 4-20 mA/HART loop. The THUM Adapter causes a small voltage drop on the loop which is linear from 2.25 V at 3.5 mA to 1.2 V at 25 mA. Under fault conditions, the maximum voltage drop is 2.5 V. The THUM Adapter will not affect the 4-20 mA signal under normal or fault conditions as long as the loop has at least a 2.5 V margin at the maximum loop current (25 mA for a typical 4-20 mA/HART device).

Limit the power supply to 0.5 Amps maximum, and voltage to 30 Vdc.

Loop current	THUM Adapter voltage drop
3.5 mA	2.25 mA
25 mA	1.2 V

3.5 Load resistor

If required, add a load resistor as shown in [Figure 3-5](#), [Figure 3-9](#) and [Figure 3-13](#). The resistor should be adequately rated for the application (1W minimum) and be compatible with the supplied splice connector which accepts wire sizes from 14 to 22 AWG.

3.6 Wiring diagrams

Figure 3-3: Direct Mount Wiring Diagram for 2-Wire Device

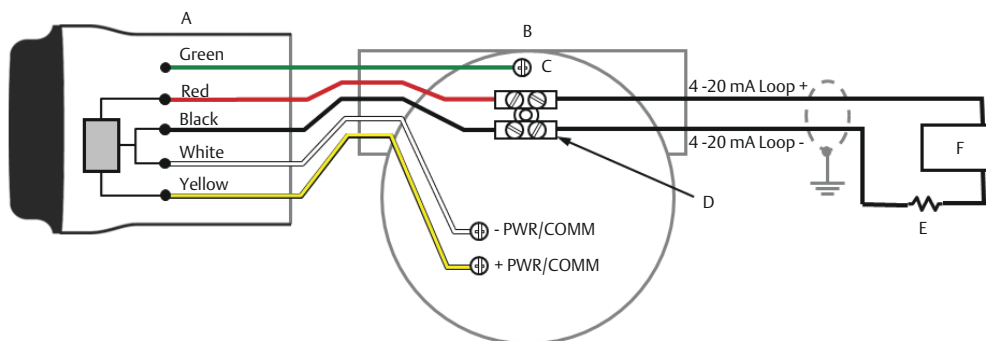

- A. THUM Adapter
- B. Wired device
- C. Ground
- D. Splice connector
- E. Load resistor $\geq 250 \text{ } \Omega$
- F. Power supply

Note

In order for the THUM Adapter to function properly there must be at least 250 Ohms resistance in the loop. If the 4-20 mA loop does not have the required resistance, wire a resistor as shown in [Figure 3-5](#), [Figure 3-9](#), or [Figure 3-13](#) as applicable.

Figure 3-4: Remote Mount Wiring Diagram for 2-Wire Device

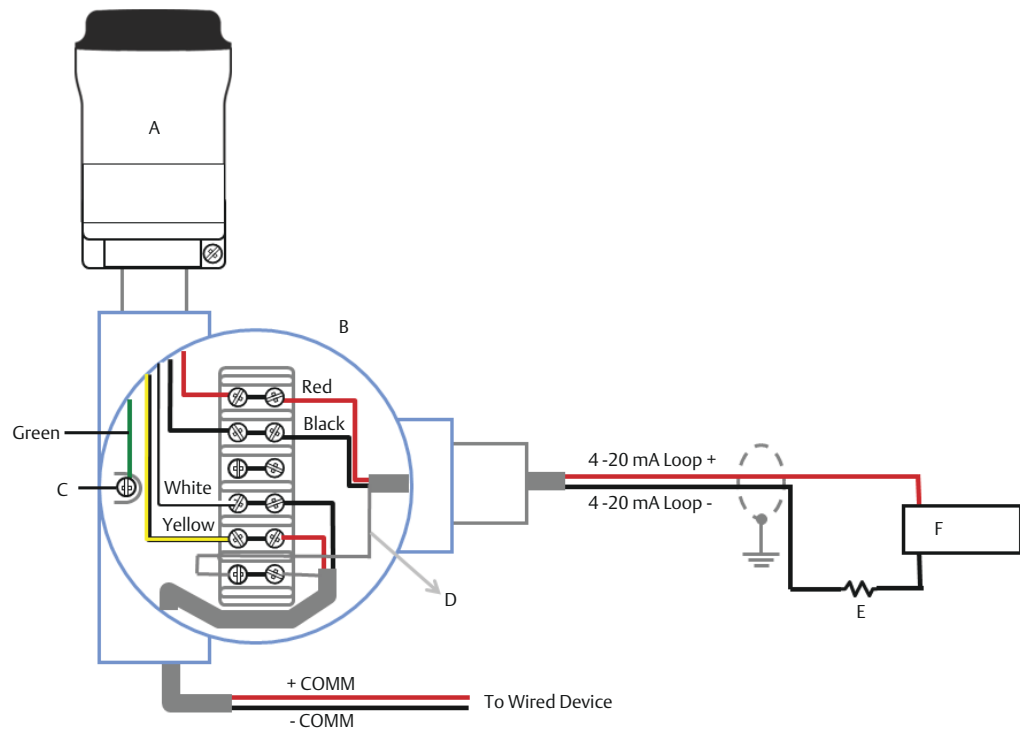

- A. THUM Adapter
- B. Remote mount housing
- C. Ground
- D. Shield wire
- E. Load resistor $\geq 250 \Omega$
- F. Power supply

Figure 3-5: Direct Mount Diagram for 2-Wire Device with Resistor

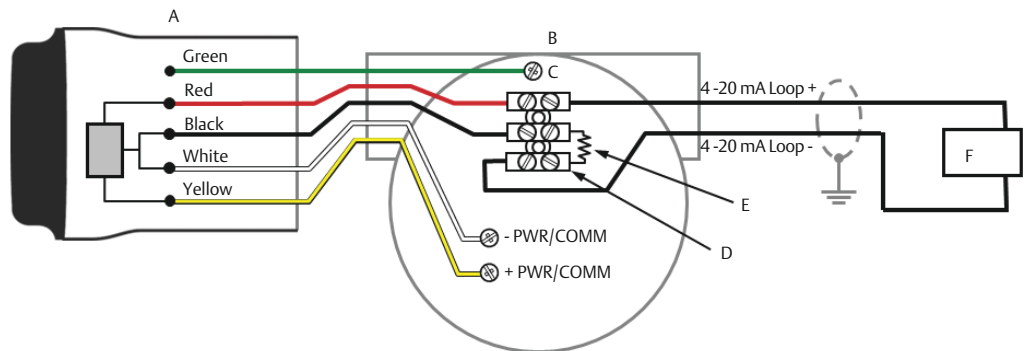

- A. THUM Adapter
- B. Wired device
- C. Ground
- D. Splice connector
- E. Load resistor $\geq 250 \Omega$
- F. Power supply

Figure 3-6: Direct Mount Wiring Diagram for 2-Wire Device with Resistor

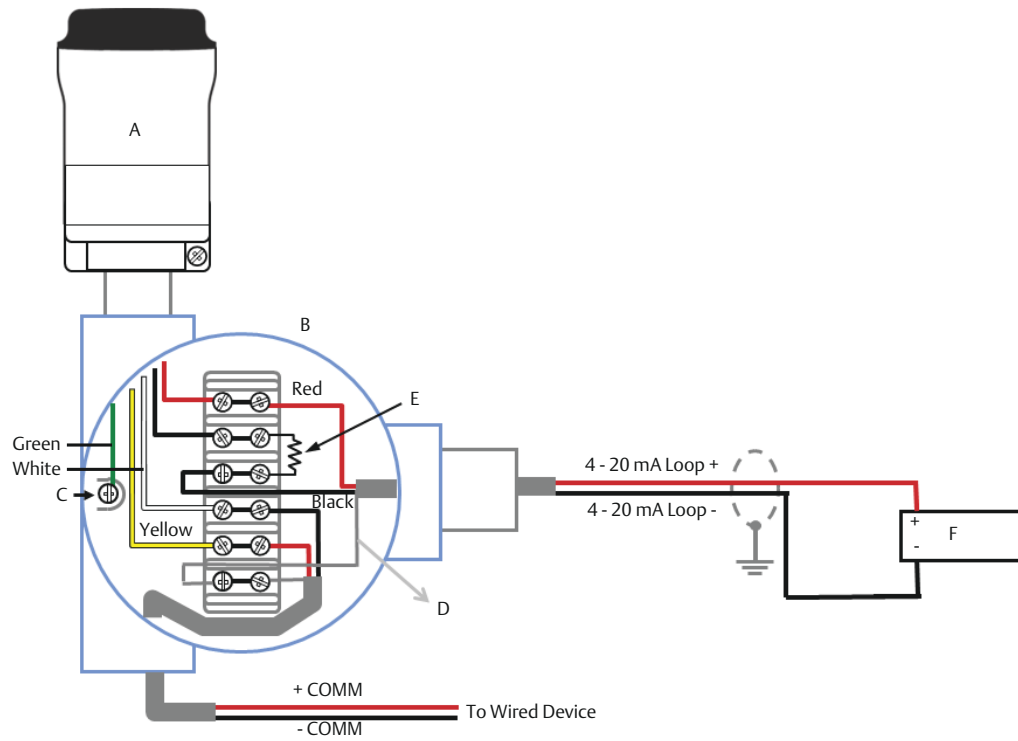

- A. THUM Adapter
- B. Remote mount housing
- C. Ground
- D. Shield wire
- E. Load resistor $\geq 250 \Omega$
- F. Power supply

Figure 3-7: Direct Mount Wiring Diagram for 4-Wire Passive Device

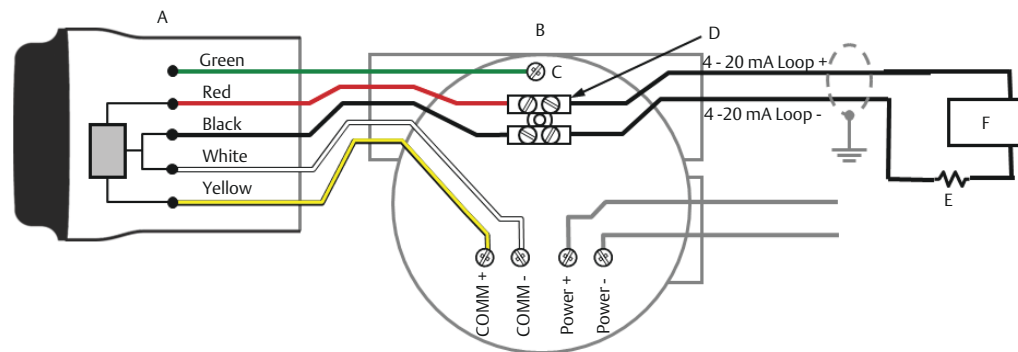

- A. THUM Adapter
- B. Wired device
- C. Ground
- D. Splice connector
- E. Load resistor $\geq 250 \Omega$
- F. Power supply

Note

A passive loop exists when the wired device is not supplying power to the 4–20 mA loop. It is important to verify if the wired device is operating in active or passive mode.

Figure 3-8: Remote Mount Wiring Diagram for 4-Wire Passive Device

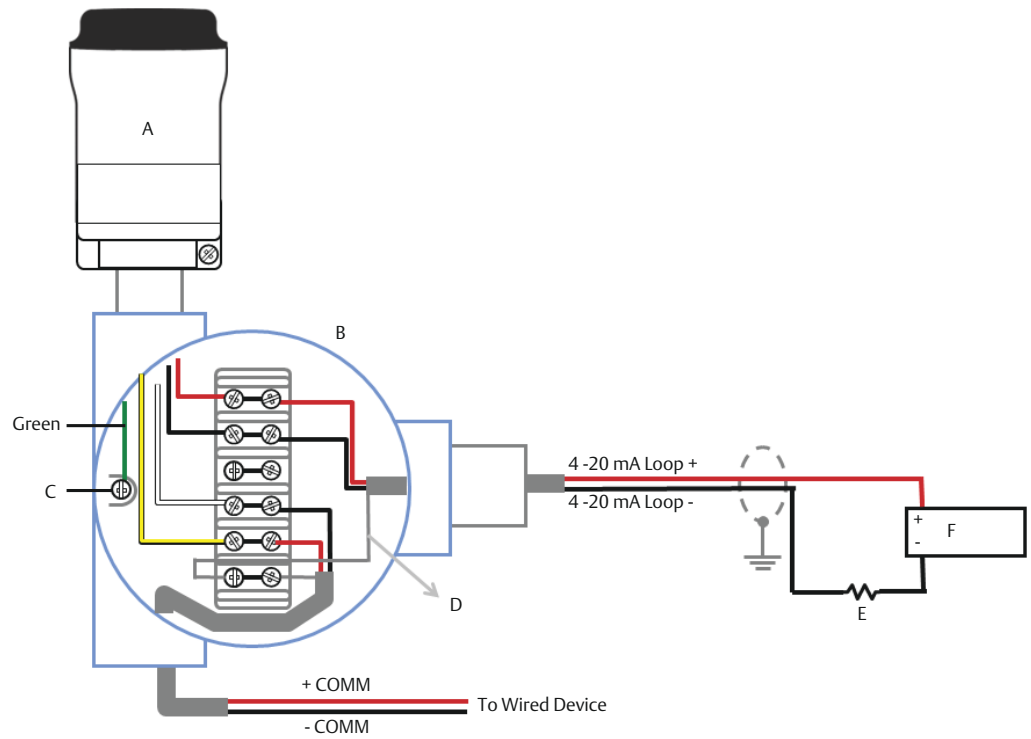

- A. THUM Adapter
- B. Remote mount housing
- C. Ground
- D. Shield wire
- E. Load resistor $\geq 250 \Omega$
- F. Power supply

Figure 3-9: Direct Mount Wiring Diagram for 4-Wire Passive Device with Resistor

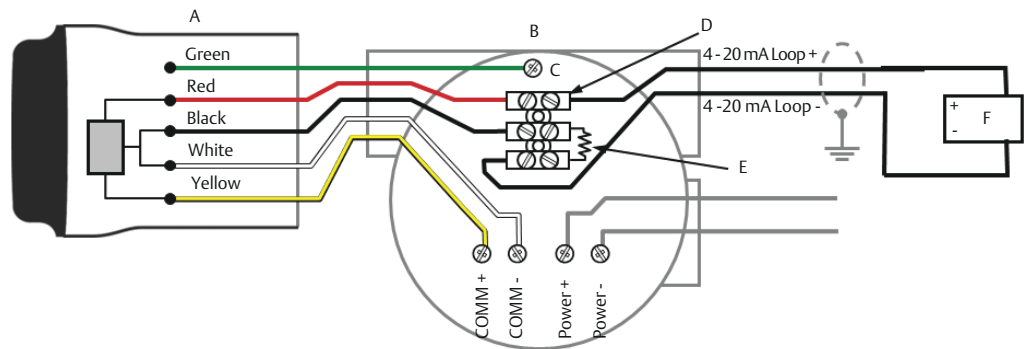

- A. THUM Adapter
- B. Wired device
- C. Ground
- D. Splice connector
- E. Load resistor $\geq 250 \Omega$
- F. Power supply

Figure 3-10: Remote Mount Wiring Diagram for 4-Wire Passive Device with Resistor

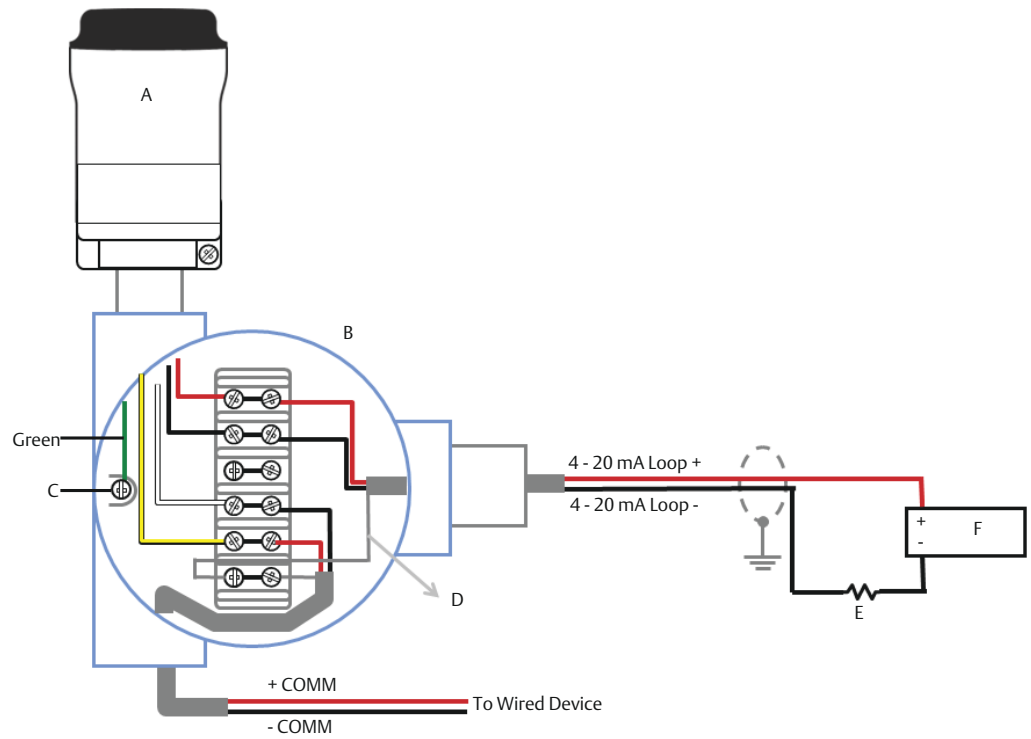

- A. THUM Adapter
- B. Remote mount housing
- C. Ground
- D. Shield wire
- E. Load resistor $\geq 250 \Omega$
- F. Power supply

Figure 3-11: Direct Mount Wiring Diagram for 4-Wire Active Device

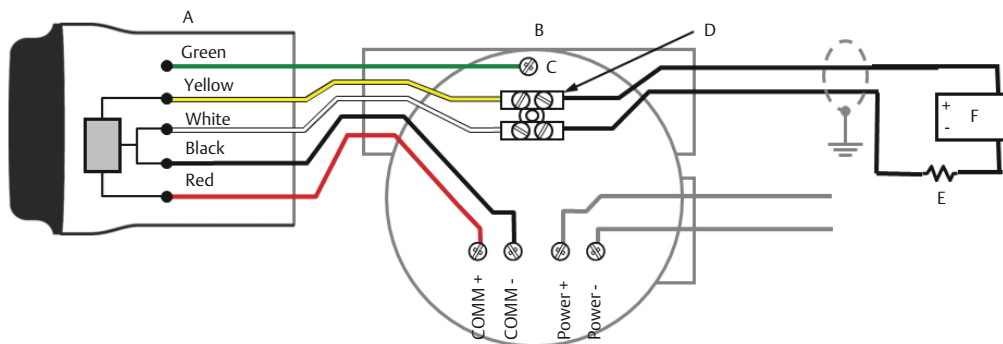

- A. THUM Adapter
- B. Wired device
- C. Ground
- D. Splice connector
- E. Load resistor $\geq 250 \Omega$
- F. Input card

Note

An active loop exists when the wired device is supplying the power to the 4–20 mA loop. It is important to verify if the wired device is operating in active or passive mode.

Figure 3-12: Remote Mount Wiring Diagram for 4-Wire Active Device

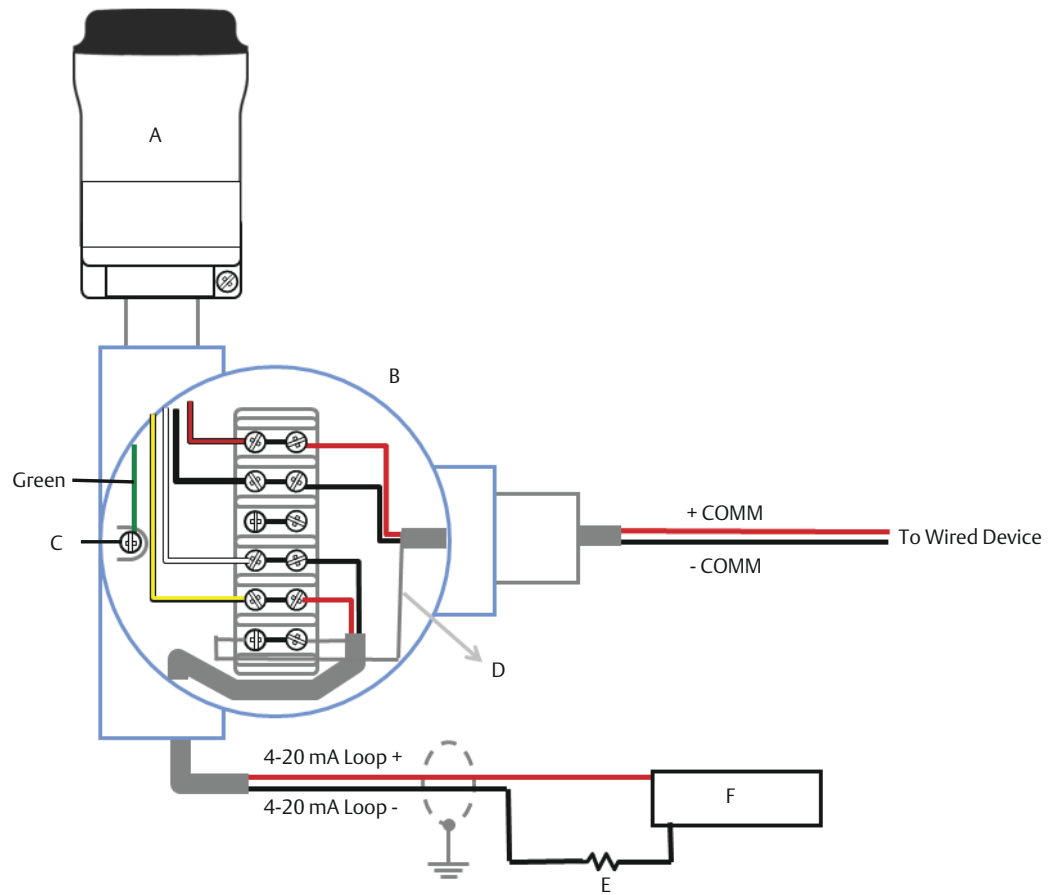

- A. THUM Adapter
- B. Remote mount housing
- C. Ground
- D. Shield wire
- E. Load resistor $\geq 250 \Omega$
- F. Input card

Figure 3-13: Direct Mount Wiring Diagram for 4-Wire Active Device with Resistor

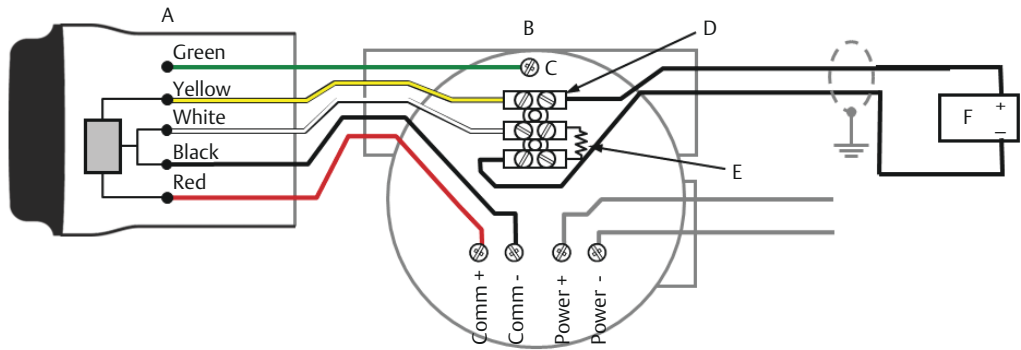

- A. THUM Adapter
- B. Wired device
- C. Ground
- D. Splice connector
- E. Load resistor $\geq 250 \Omega$
- F. Input card

Figure 3-14: Remote Mount Wiring Diagram for 4-Wire Active Device with Resistor

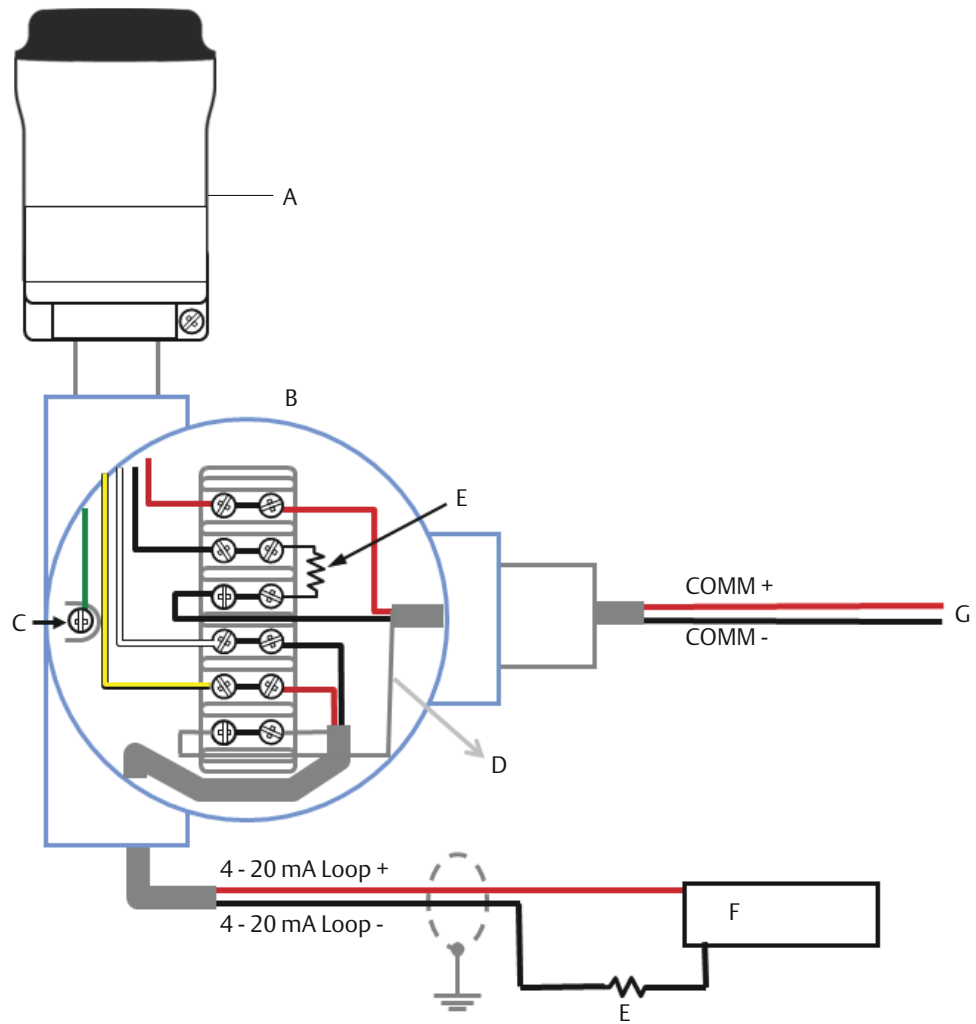

- A. THUM Adapter
- B. Remote mount housing
- C. Ground
- D. Shield wire
- E. Load resistor $\geq 250 \Omega$
- F. Input card
- G. To wired device

Figure 3-15: Direct Mount Wiring Diagram for 4-Wire Active Device with No 4-20 mA Loop

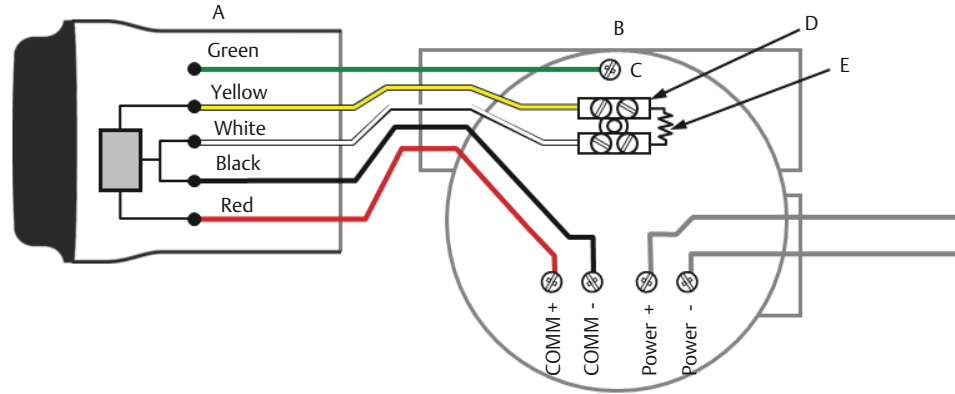

- A. THUM Adapter
- B. Wired device
- C. Ground
- D. Splice connector
- E. Load resistor $\geq 250 \Omega$

Figure 3-16: Remote Mount Wiring Diagram for 4-Wire Active Device with No 4-20 mA Loop

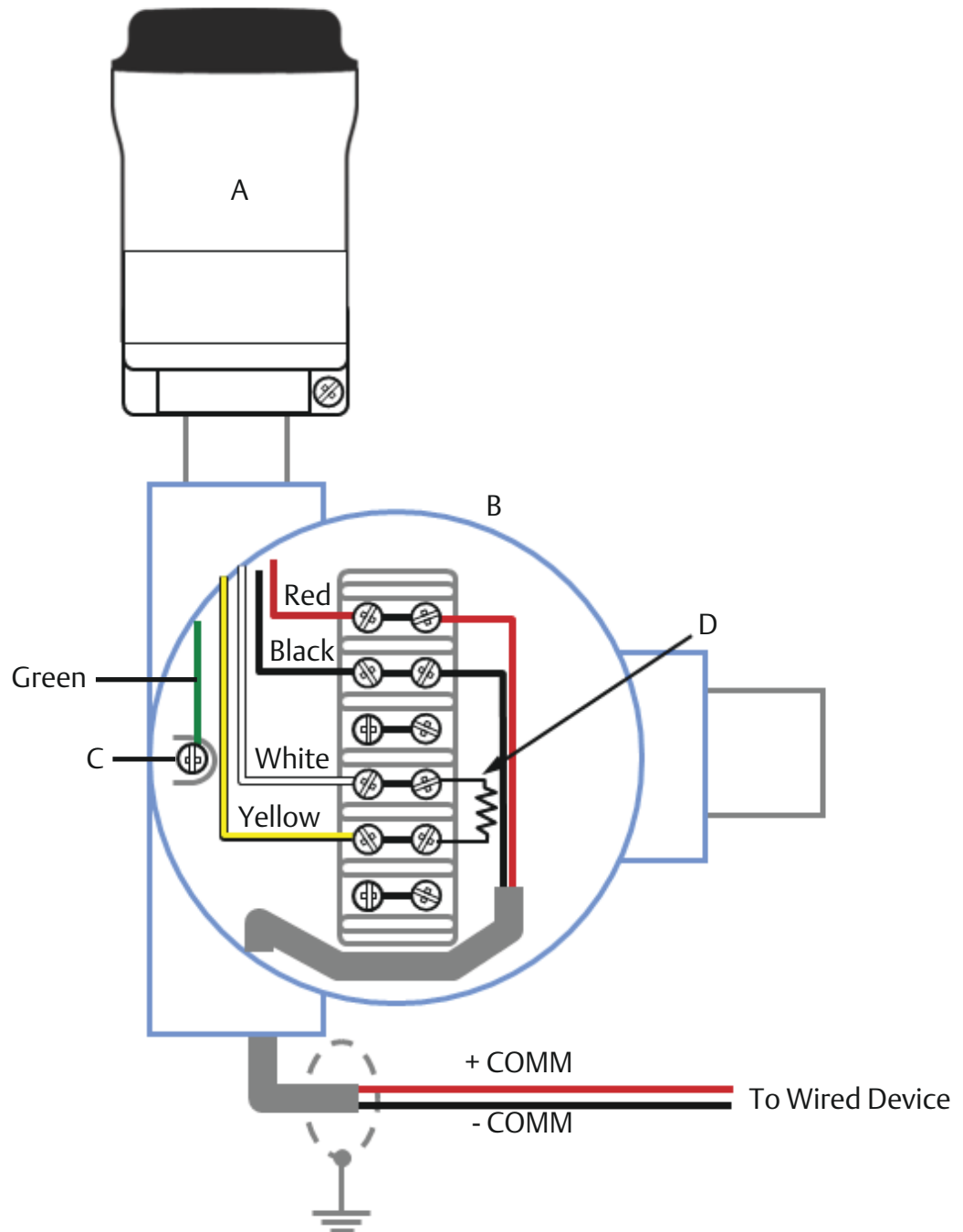

- A. THUM Adapter
- B. Remote mount housing
- C. Ground
- D. Load resistor $\geq 250 \Omega$

Figure 3-17: THUM Adapter only, Powered by a 24 V Power Supply with 1200 Ohm resistor to limit current to 20 mA

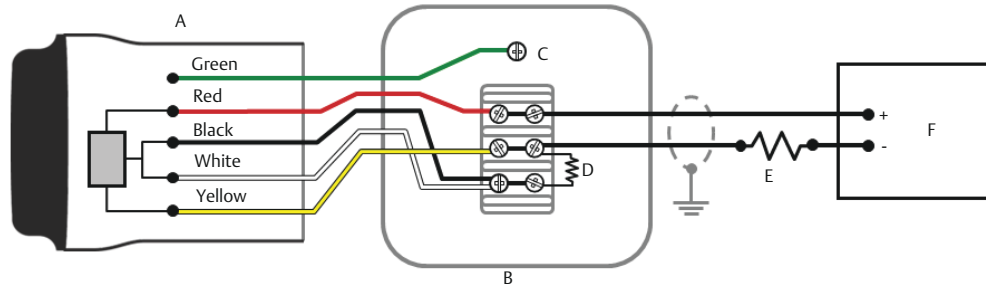

- A. THUM Adapter
- B. Junction box
- C. Ground
- D. 250 Ω resistor
- E. 1200 Ohm resistor required
- F. 24 V power supply

Figure 3-18: THUM Adapter only, Powered by a 24 V Power Supply with 1200 Ohm Resistor to Limit Current to 20 mA

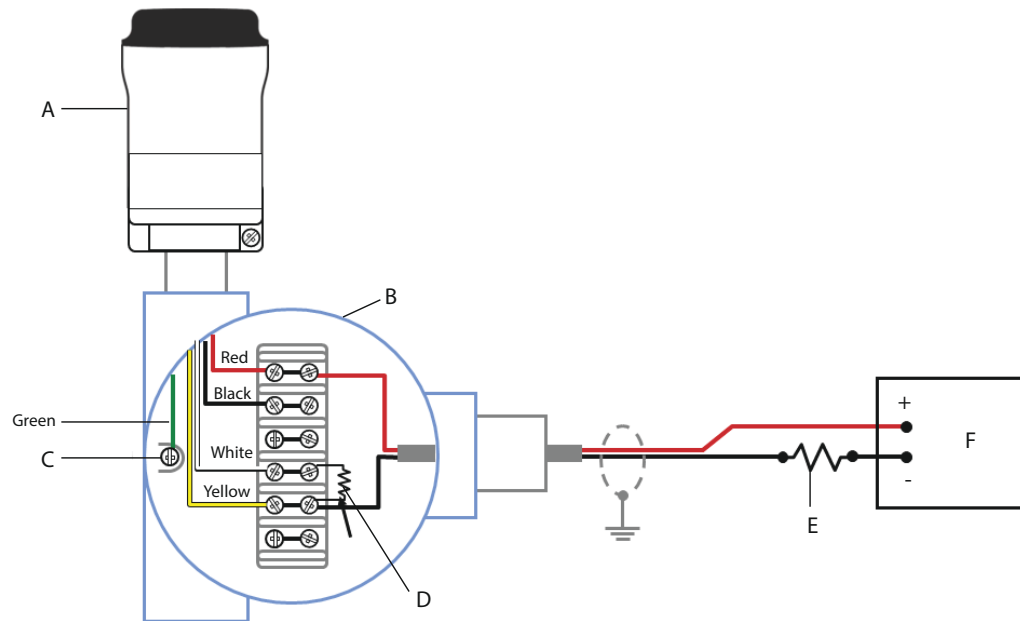

- A. THUM Adapter
- B. Remote mount housing
- C. Ground
- D. 250 Ω resistor
- E. 1200 ohm resistor required
- F. 24 V power supply

3.7 Loop current test

To verify that the THUM Adapter will work under all conditions, a loop current test should be performed. This test will exercise the loop under the highest possible voltage drop conditions.

Procedure

1. Place loop in manual control.
2. Drive loop to high alarm level. For details, see wired device instruction manual.
 - When the THUM Adapter is connected to a valve, this will need to be done at the current source and not from the valve.
 - When the THUM Adapter is connected to a transmitter, this will need to be performed at the transmitter.
3. Place the THUM Adapter into fixed voltage drop mode.

3.7.1 Perform loop current test using AMS Device Manager (Fixed Voltage Drop)

Figure 3-19: AMS Device Manager Configure Screen

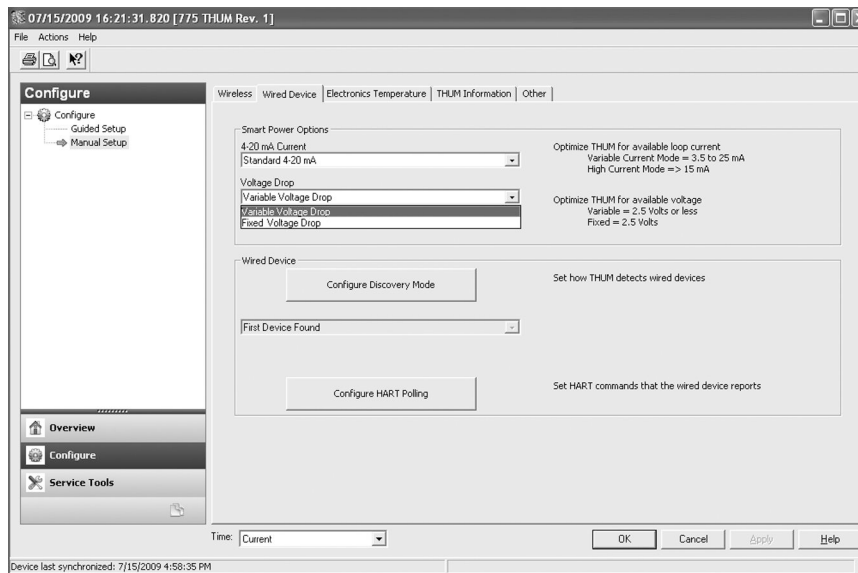

Procedure

1. Right-click on the THUM Adapter and select **Configure**.
2. When the menu opens, select **Manual Setup** from the window on the left and select the **Wired Device** tab on the top.
3. Make sure the **Time** drop down menu at the bottom of the page has **Current** selected.
4. Under the **Voltage Drop** drop down menu in the **Smart Power Options** box, select **Fixed Voltage Drop**.
5. Select **Apply** to make any changes.

3.7.2 Perform Loop Current Test Using Field Communicator (Fixed Voltage Drop)

Procedure

1. When communicating to the THUM Adapter, select **Configure** → **Manual setup** → **Wired Device** → **Voltage Drop Mode**.
2. In the method, select **Fixed Voltage Drop**.

Function	Key sequence	Menu items
Voltage Drop	2,2,2,2	Voltage Drop

3. Verify the current on the loop reaches the high alarm levels.
4. Place the THUM Adapter into variable voltage drop mode.

3.7.3 Perform loop current test using AMS Device Manager (Variable Voltage Drop)

Figure 3-20: AMS Device Manager Configure Screen

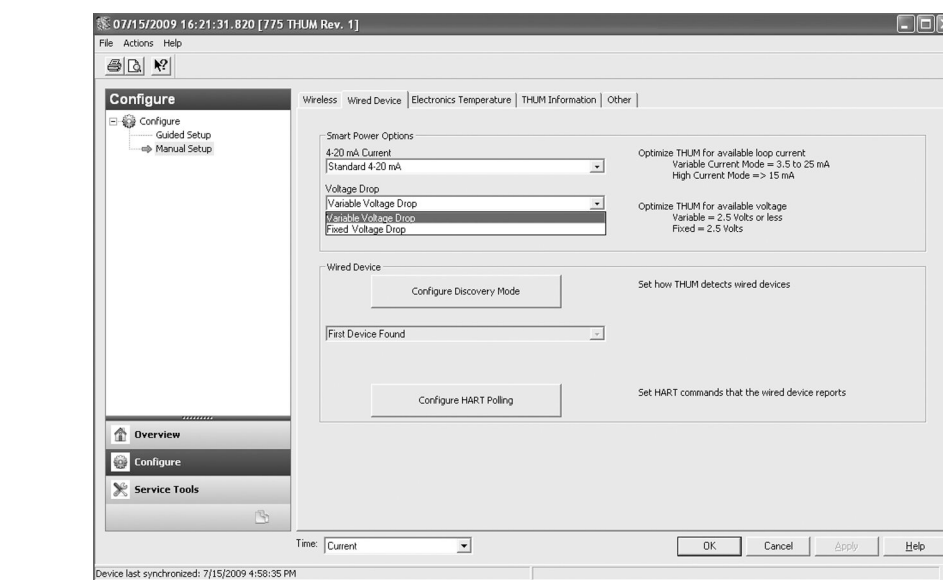

Procedure

1. Right-click on the THUM Adapter and select **Configure**.
2. When the menu opens, select **Manual Setup** from the window on the left and select the **Wired Device** tab on the top.
3. Make sure the **Time** drop down menu at the bottom of the page has **Current** selected.
4. Under the **Voltage Drop** drop down menu in the **Smart Power Options** box, select **Variable Voltage Drop**.
5. Select **Apply** to make any changes.

3.7.4 Perform loop current test using field communicator (Variable Voltage Drop)

Procedure

1. When communicating to the THUM Adapter, select **Configure** → **Manual setup** → **Wired Device** → **Voltage Drop Mode**.
2. In the method, select **Variable Voltage Drop**.

Function	Key sequence	Menu items
Voltage Drop	2,2,2,2	Voltage Drop

3. Remove the loop from high alarm value.

4 Commissioning

4.1 Safety messages

Instructions and procedures in this section may require special precautions to ensure the safety of the personnel performing the operations. Information that potentially raises safety issues is indicated by a warning symbol (⚠). Please refer to the following safety messages before performing an operation preceded by this symbol.

⚠ WARNING

Failure to follow these installation guidelines could result in death or serious injury.

Only qualified personnel should perform the installation

Explosions could result in death or serious injury.

Before connecting a field communicator in an explosive atmosphere, make sure that the instruments are installed in accordance with intrinsically safe or non-incendive field wiring practices

Verify that the operating atmosphere of the transmitter is consistent with the appropriate hazardous locations certifications

Electrical shock could cause death or serious injury.

Use extreme caution when making contact with the leads and terminals

This device complies with Part 15 of the FCC Rules. Operation is subject to the following conditions: This device may not cause harmful interference. This device must accept any interference received, including interference that may cause undesired operation.

This device must be installed to ensure a minimum antenna separation distance of 20 cm from all persons.

4.2 Device network configuration

In order to communicate with the Emerson Wireless Gateway, and ultimately the Information System, the transmitter must be configured to communicate with the wireless network. This step is the wireless equivalent of connecting wires from a transmitter to the information system.

Procedure

1. Using a Field Communicator or AMS Device Manager, enter the **Network ID** and **Join Key** so that they match the Network ID and Join Key of the Gateway and other devices in the network.
If the Network ID and Join Key are not identical, the Emerson Wireless 775 THUM™ Adapter will not communicate with the network.
2. The Network ID and Join Key may be obtained from the Gateway on the **Setup** → **Network** → **Settings** page on the web server.

Figure 4-1: Gateway Network Settings

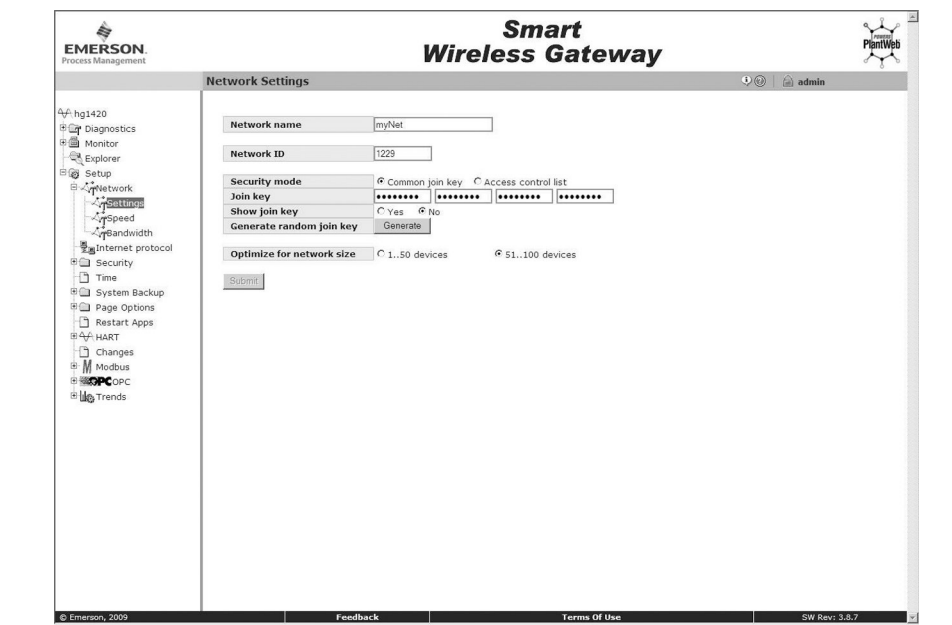

4.2.1 AMS Device Manager

Right-click on the THUM Adapter and select Configure. When the menu opens, select **Join Device to Network** and follow the method to enter the Network ID and Join Key.

4.2.2 Field Communicator

The Network ID and Join Key may be changed in the wireless device by using the following Fast Key sequence. Set both Network ID and Join Key.

Function	Fast Key seques	Menu Items
Wireless Setup	1, 4	Smart Power, Network ID, Set Join Key, Radio State

4.3 Network status

If the THUM™ Adapter was configured with the Network ID and Join Key and sufficient time for network polling has passed, the transmitter should be connected to the network. To verify connectivity, open the Gateway’s integral web interface and navigate to the *Explorer* page.

Figure 4-2: Gateway Explorer Page

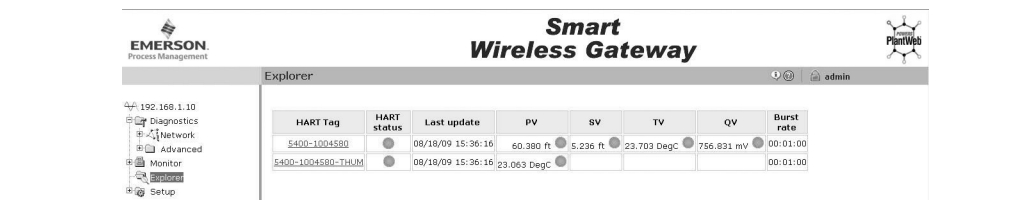

This page will display the THUM Adapter's HART tag, PV, SV, TV, QV, and Update Rate. A green status indicator means that the device is working properly. A red indicator means that there is a problem with either the device or its communication path. For more detail on a specific device, click on the tag name.

4.4 Verify operation

Operation can be verified using one of three methods: Field Communicator, the Wireless Gateway's integrated web interface, or via AMS Device Manager.

4.4.1 Verify operation using Field Communicator

For HART Wireless transmitter communication, a THUM Adapter DD is required. The Field Communicator must be put into poll mode using the THUM Adapter address of 63. Use the wired device documentation to connect the Field Communicator to the THUM Adapter.

Table 4-1: Field Communicator Connections

Function	Fast Key sequence	Menu items
Communications	3, 3	Join Status, Wireless Mode, Join Mode, Number of Available Neighbors, Number of Advertisements Heard, Number of Join Attempts

4.4.2 Verify operation using Emerson Wireless Gateway

If the THUM Adapter was configured with the Network ID and Join Key, and sufficient time has passed for network polling, the transmitter will be connected to the network. To verify device operation and connection to the network with the Gateway's integrated web server, open the Gateway's integral web interface and navigate to the *Explorer* page.

Note

It may take several minutes for the device to join the network.

4.4.3 Verify operation using AMS Device Manager

When the device has joined the network, it will appear in the AMS Device Manager as illustrated in [Figure 4-3](#).

Figure 4-3: AMS Device Manger

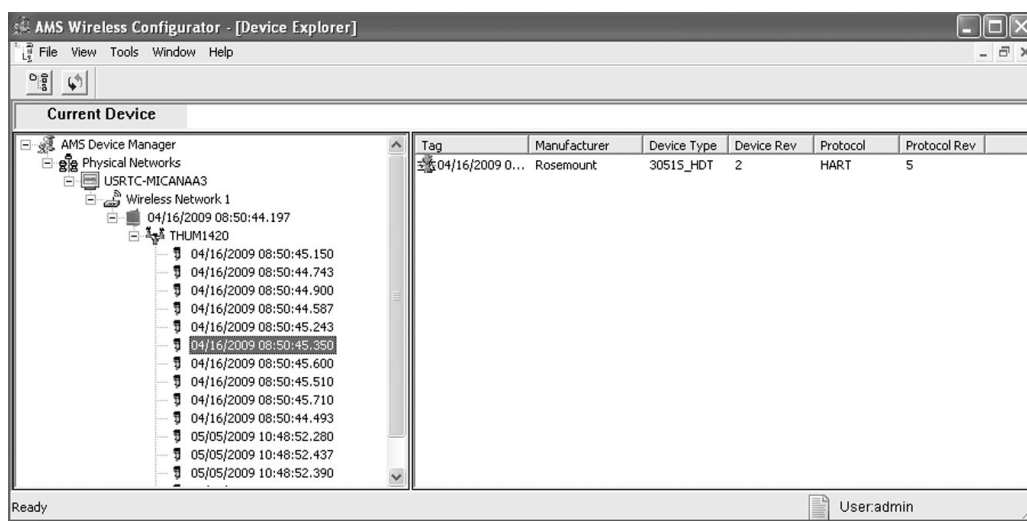

4.4.4 Troubleshooting

If the device is not operating properly, refer to the [Troubleshooting](#) of the manual. The most common cause of incorrect operation is the Network ID and Join Key. The Network ID and Join Key in the device must match that of the Gateway.

The Network ID and Join Key may be obtained from the Gateway on the **Setup** → **Network** → **Settings** page on the web server. The Network ID and Join Key may be changed in the wireless device by using the following Fast Key sequence.

Function	Fast Key sequence	Menu items
Wireless Setup	1, 4	Smart Power, Network ID, Set Join Key, Radio State

4.4.5 Reference information

Note

In order to communicate with a Field Communicator, the wired device must be powered.

Table 4-2: THUM Adapter Fast Key Sequence

Function	Fast Key sequence	Menu items
Device Info	2, 2, 4, 3	Manufacturer, Model, Final Assembly Number, Universal, Field Device, Software, Hardware, Descriptor, Message, Date, Model Number I, II, III, SI Unit Restriction, Country
Guided Setup	2, 1	Configure, Guided Setup, Join Device to Network, Configure Update Rate, Zero Trim, Configure Device Display, Configure Process Alarms
Manual Setup	2, 2	Configure, Manual Setup, Wireless, Pressure, Device Temperatures, Device Information, Display, Other
Wireless	2, 2, 1	Network ID, Join Device to Network, Configure Update Rate, Configure Broadcast Power Level, Power Mode, Power Source

5 Operation and maintenance

5.1 Safety messages

Instructions and procedures in this section may require special precautions to ensure the safety of the personnel performing the operations. Information that potentially raises safety issues is indicated by a warning symbol () . Please refer to the following safety messages before performing an operation preceded by this symbol.

⚠ WARNING

Failure to follow these installation guidelines could result in death or serious injury.

Only qualified personnel should perform the installation

Explosions could result in death or serious injury.

Before connecting a field communicator in an explosive atmosphere, make sure that the instruments are installed in accordance with intrinsically safe or non-incendive field wiring practices

Verify that the operating atmosphere of the transmitter is consistent with the appropriate hazardous locations certifications

Electrical shock could cause death or serious injury.

Use extreme caution when making contact with the leads and terminals

This device complies with Part 15 of the FCC Rules. Operation is subject to the following conditions: This device may not cause harmful interference. This device must accept any interference received, including interference that may cause undesired operation.

This device must be installed to ensure a minimum antenna separation distance of 20 cm from all persons.

5.2 Startup sequence

Because the Emerson™ Wireless 775 THUM™ Adapter is a power scavenging device, different capabilities are available at different times after startup. Configuration is available immediately after startup and includes Update Rate and Discovery method. All network settings including Network ID and Join Key can not be set until the radio is completely initialized. This may take up to three minutes after startup.

After the radio completes initialization, the THUM adapter begins to join the network. Time to join the network depends on network size and number of devices and if active advertising is turned on in the Gateway. After sufficient time to join has passed go to the Explorer page on the Emerson Wireless Gateway to see if the THUM Adapter has joined.

5.3 Advanced setup

5.3.1 Configure advanced update rate method

The Configure Update Rate method sets all three update rates based on one user input. The Configure Advanced Update Rate method allows for each update rate to be set independently of the other two. Values for all update rates are between eight seconds and 60 minutes.

Note

Only one update rate can be set to eight seconds.

Fast Keys
2,2,1,3

In AMS Device Manager, select **Manual Setup** → **Wireless**.

5.3.2 4-20 mA current

This optimizes the THUM Adapter to the available loop current. There are two options Variable Current Mode and Fixed Current Mode.

Fixed Current mode is user selectable. This mode is for when the current on the loop is fixed and will not drop below 15 mA.

Note

If the current drops below 15 mA when the THUM Adapter is in fixed current mode, there may be issues with network traffic, and the THUM Adapter may drop off of the wireless network.

The HART[®] loop will not be affected.

Fast Keys
2,2,1,3

In AMS Device Manager, select **Manual Setup** → **Wired Device**.

5.3.3 Voltage drop

Fast Keys
2,2,2,2

This optimizes the THUM Adapter to the available voltage on the loop. There are two options: Variable and Fixed.

Variable Mode Default Mode. In Variable mode the THUM drops between 2.25 V at 3.5 mA and 1.2 V at 25 mA.

Fixed Mode In Fixed mode the THUM will always drop 2.25 volts. Fixed mode is used for verifying that there is enough voltage on the loop in the loop check procedure.

In AMS Device Manager, select **Manual Setup** → **Wired Device**.

5.3.4 Discovery mode

The discovery mode is how the THUM Adapter determines which wired device it will update.

Fast Keys
2,2,2,3

Discovery Modes

- First Device Found** Default Mode. In First Device Found Mode, the THUM Adapter will update for the first wired device that it finds on the wired bus. This mode is best used when there is only one device on the wired bus. If more than one wired device is found, the THUM Adapter will go into alert.
- Fixed Polling Address** In Fixed Polling Address Mode, the THUM will only update for a wired device at specific HART polling address. Any address can be entered. If no device is found at this address, the THUM Adapter will go into an alarm state.
- Fixed Mapping** In Fixed Mapping mode, the user selects the long tag from a list of devices that are currently on the wired bus. If the selected device goes off line, the THUM will not start updating new device, and will go into an alarm state.

In AMS Device Manager, select **Manual Setup** → **Wired Device**.

5.3.5 Configure HART polling method

Fast Keys
2,2,2,4

The Configure HART Polling method allows the user to select which commands the THUM Adapter will update for the wired device. The user can select from pre-setup information or select **Custom** and enter the HART command that they would like to have the THUM Adapter update for the wired device.

In AMS Device Manager, select **Manual Setup** → **Wired Device**.

5.3.6 Configure router only mode

Fast Keys
2,2,5,2

This mode will set the THUM Adapter up as a router only device. The THUM Adapter will no longer look for wired devices or update for any wired device that is on the HART loop. The THUM Adapter will continue to send updates for itself and will also act as a wireless node in the wireless network.

In AMS Device Manager, select **Manual Setup** → **Other**.

5.3.7 HART polling address

Fast Keys
2,2,5,3

This is the HART Polling address of the THUM adapter. This can be changed from 0 to 63. This is used when using wired HART communication to talk with the THUM. The THUM Adapter default HART polling address is 63.

In AMS Device Manager, select **Manual Setup** → **Other**.

5.3.8 HART master

Fast Keys
2,2,5,4

Here is where the user can set the THUM Adapter to either a primary or secondary HART master. The THUM is set to primary as default, if another primary master is on the HART loop it may be necessary to change the THUM Adapter to a secondary master. This will not affect the functionality of the THUM Adapter. The number of retries can be set to between two and five.

In AMS Device Manager, select **Manual Setup** → **Other**.

6 Troubleshooting

6.1 Overview

Troubleshooting provides summarized maintenance and troubleshooting suggestions for the most common operating problems.

If you suspect malfunction despite the absence of any diagnostic messages on the Field Communicator display, follow the procedures described here to verify that transmitter hardware and process connections are in good working order. Always deal with the most likely checkpoints first.

⚠ WARNING

Failure to follow these installation guidelines could result in death or serious injury.

Only qualified personnel should perform the installation

Explosions could result in death or serious injury.

Before connecting a field communicator in an explosive atmosphere, make sure that the instruments are installed in accordance with intrinsically safe or non-incendive field wiring practices

Verify that the operating atmosphere of the transmitter is consistent with the appropriate hazardous locations certifications

Electrical shock could cause death or serious injury.

Use extreme caution when making contact with the leads and terminals

This device complies with Part 15 of the FCC Rules. Operation is subject to the following conditions: This device may not cause harmful interference. This device must accept any interference received, including interference that may cause undesired operation.

This device must be installed to ensure a minimum antenna separation distance of 20 cm from all persons.

6.1.1 Troubleshooting

Table 6-1: Troubleshooting Recommended Actions

Symptom	Recommended action
Wired troubleshooting	
Wired device does not turn on when THUM Adapter is added to loop	Check the wiring and connections between Emerson Wireless 775 THUM Adapter and wired device. Verify that enough voltage is being supplied to power both the THUM Adapter and wired device.
Wired Device does not function properly through loop check	<ul style="list-style-type: none"> Determine total voltage drop of system assume 2.5 volts for THUM Adapter Verify that enough voltage is on the loop

Table 6-1: Troubleshooting Recommended Actions (continued)

Symptom	Recommended action
Can not communicate with wired device or THUM Adapter	<ul style="list-style-type: none"> • Verify that wiring is correct • Verify that enough voltage is being supplied to power both THUM Adapter and wired device • Verify that between 250 and 1100 Ohms resistance is present
Can not communicate with THUM Adapter	<ul style="list-style-type: none"> • Verify that wiring is correct • Verify that enough voltage is being supplied to power both THUM Adapter and wired device • Verify that between 250 and 1100 Ohms resistance is present • Verify that Field communicator or AMS Device Manager is set to poll for THUM Adapter address Power Cycle device to try again
Configuration troubleshooting	
Can not configure THUM Adapter with Field Communicator or AMS Device Manager	Make sure that the correct DD is loaded into the Field Communicator or AMS Device Manager
THUM Adapter does not communicate with wired device	<ol style="list-style-type: none"> 1. Run the Configure Discovery Mode method to connect the THUM Adapter to wired device 2. Check the wiring and connections between THUM Adapter and wired device 3. Verify that between 250 and 1100 Ohms resistance is present for HART Communications 4. Verify that the wired device is functioning properly Power Cycle device to try again
Duplicate HART Master Detected	<ol style="list-style-type: none"> 1. Verify that two primary masters are on the loop. 2. Then set the THUM Adapter into secondary master mode. 3. Power Cycle device to try again. 4. If THUM Adapter is in secondary master mode and Field Communicator or AMS Device Manager is connected to loop this error will occur. 5. The error will disappear after the Field Communicator or AMS Device Manager is removed from the loop.
Wireless network troubleshooting	

Table 6-1: Troubleshooting Recommended Actions (continued)

Symptom	Recommended action
THUM Adapter not joining network	<ol style="list-style-type: none"> 1. Verify network ID and join key 2. Wait longer (30 minute) 3. Verify THUM Adapter is within range of at least one other device 4. Verify network is in active network advertise 5. Power Cycle device to try again 6. Verify device is configured to join. Send the "Force Join" command to the device 7. See troubleshooting section of Emerson Wireless Gateway for more information
Limited Bandwidth Error	<ol style="list-style-type: none"> 1. Reduce the Update Rate on THUM Adapter and wired device 2. Increase communication paths by adding more wireless points 3. Check that THUM Adapter has been online for at least an hour 4. Check that THUM Adapter is not routing through a limited routing node 5. Create a new network with an additional Gateway

6.2 Service support

To expedite the return process outside of North America, contact your Emerson representative.

Within the United States, call the Emerson Process Management Response Center toll-free number 1.800.654.7768. The center, which is available 24 hours a day, will assist you with any needed information or materials.

The center will ask for product model and serial numbers, and will provide a Return Material Authorization (RMA) number. The center will also ask for the process material to which the product was last exposed.

⚠ CAUTION

Individuals who handle products exposed to a hazardous substance can avoid injury if they are informed of, and understand, the hazard. If the product being returned was exposed to a hazardous substance as defined by OSHA, a copy of the required Material Safety Data Sheet (MSDS) for each hazardous substance identified must be included with the returned goods.

A Specifications and reference data

A.1 Functional specifications

A.1.1 Input

Any 2-wire, 3-wire, or 4-wire HART powered device

A.1.2 Output

IEC 62591 (*WirelessHART*[®])

A.1.3 Humidity limits

0 - 100% relative humidity

A.1.4 Update rate

User selectable, eight seconds to 60 minutes

A.2 Physical specifications

A.2.1 Material selection

Emerson provides a variety of Rosemount products with various product options and configurations, including materials of construction that can be expected to perform well in a wide range of applications. The Rosemount product information presented is intended as a guide for the purchaser to make an appropriate selection for the application. It is the purchaser's sole responsibility to make a careful analysis of all process parameters (such as all chemical components, temperature, pressure, flow rate, abrasives, contaminants, etc.), when specifying product, materials, options, and components for the particular application. Emerson is not in a position to evaluate or guarantee the compatibility of the process fluid or other process parameters with the product, options, configuration, or materials of construction selected.

A.2.2 Electrical connections

The THUM Adapter is connected into a powered 4–20 mA loop, powering itself by scavenging power. The THUM Adapter causes a voltage drop across the loop. The drop is linear from 2.25 V at 3.5 mA to 1.2 V at 25 mA, but does not effect the 4–20 mA signal on the loop. Under fault conditions, the maximum voltage drop is 2.5 V.

A.2.3 Power supply

Minimum load on loop 250 Ohms

To maintain normal operating functions of the sub-device, the power in the loop must have at least a 2.5 V margin at a 250 Ω load.

Limit the power supply to 0.5 A maximum.
Limit the power supply to 30 Vdc maximum.

A.2.4 Field Communicator connections

Utilize wired device HART connections

A.2.5 Materials of construction

Enclosure

- Housing option D: Low-copper aluminum
- Housing option E: 316 SST
- Paint: Polyurethane
- M20 conduit adapter: SST
- M20 conduit adapter O-ring: Buna-N

Antenna

Polybutadine terephthalate (PBT)/Polycarbonate (PC) integrated omni directional antenna

A.2.6 Weight

- THUM Adapter only AL: 0.65 lb (0.29 kg)
- THUM Adapter only SST: 1.1 lb (0.5 kg)
- AL THUM Adapter with AL remote kit: 3.2 lb (1.45 kg)
- SST THUM Adapter with SST remote kit: 5.8 lb (2.65 kg)
- AL THUM Adapter with M20 conduit adapter: 0.85 lb (0.038 kg)
- SST THUM Adapter with M20 conduit adapter: 1.3 lb (0.59 kg)

A.2.7 Enclosure ratings

Housing option code D and remote mount kits are enclosure Type 4X and IP66.

A.2.8 Mounting

The THUM Adapter may be attached directly to the conduit of any 2-wire or 4-wire HART device or mounted remotely by using remote mount kit.

A.3 Performance specifications

A.3.1 ElectroMagnetic Compatibility (EMC)

Meets all industrial environments of EN61326 and NAMUR NE-21 when installed with shielded wiring. The sub-device must also use shielded wiring for installation. Maximum deviation $\leq 1\%$ span during EMC disturbance⁽¹⁾.

A.3.2 Vibration effect

Output unaffected when tested per the requirements of IEC60770-1 field with general application or pipeline with low vibration level (10–60 Hz 0.15 mm displacement peak amplitude/60–500 Hz 2 g).

When the THUM Adapter is used on wired devices that are subject to vibration levels greater than 2 g, it is recommended that the THUM Adapter be remotely mounted using the remote mount kit.

A.3.3 Temperature limits

Ambient temperature

-40 to 85 °C (-40 to 185 °F)

Storage temperature

-40 to 85 °C (-40 to 185 °F)

⁽¹⁾ During the surge event, device may exceed maximum EMC deviation limit or reset; however, device will self-recover and return to normal operation within specified start-up time.

B Dimensional Drawings

Figure B-1: THUM Adapter ½ NPT

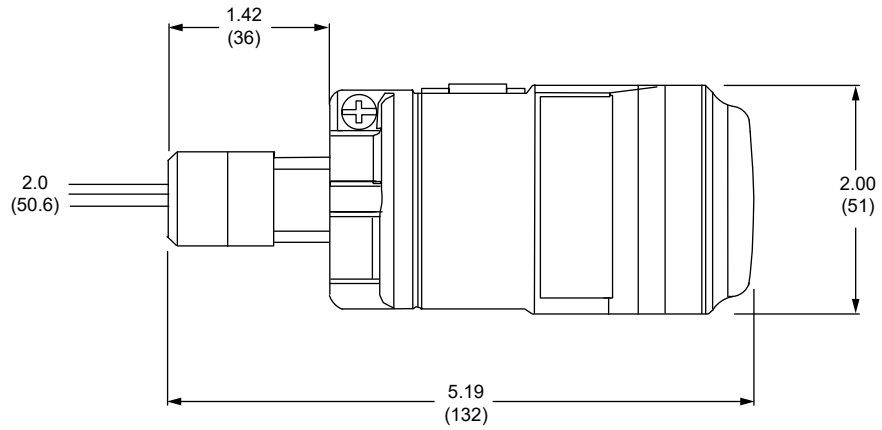

Dimensions are in inches (millimeters).

Figure B-2: THUM Adapter with M20 Conduit Adapter

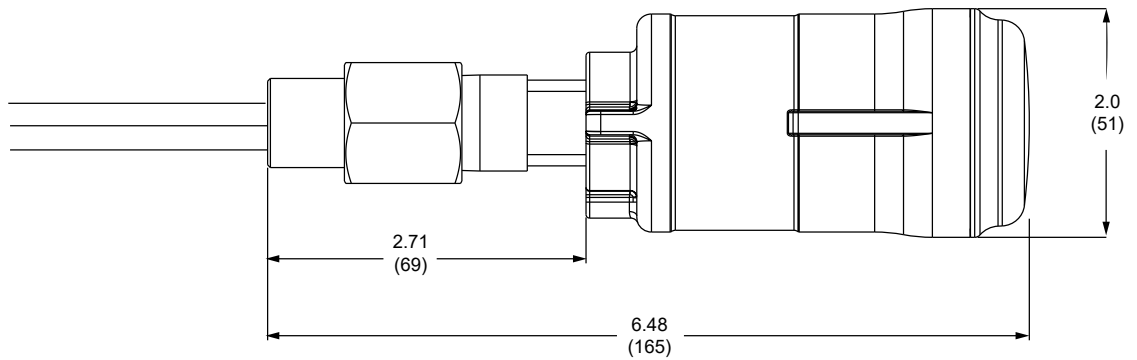

Dimensions are in inches (millimeters).

Figure B-3: THUM Adapter with Remote Mount Kit

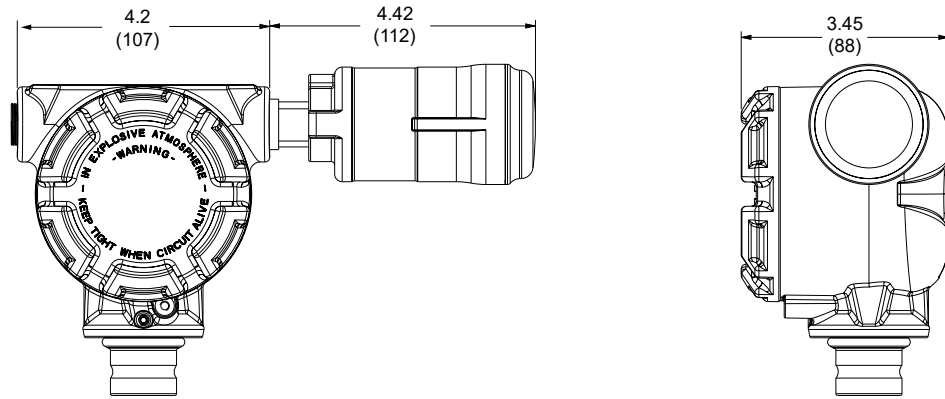

Dimensions are in inches (millimeters).

C Product Certifications

Rev 2.9

C.1 European Directive Information

A copy of the EU Declaration of Conformity can be found at the end of the Quick Start Guide. The most recent revision of the EU Declaration of Conformity can be found at [Emerson/Rosemount](#).

C.2 Ordinary location certification from FM Approvals

As standard, the transmitter has been examined and tested to determine that the design meets the basic electrical, mechanical, and fire protection requirements by FM Approvals, a nationally recognized test laboratory (NRTL) as accredited by the Federal Occupational Safety and Health Administration (OSHA).

C.3 Telecommunication compliance (for wireless products only)

All wireless devices require certification to ensure that they adhere to regulations regarding the use of the RF spectrum. Nearly every country requires this type of product certification.

Emerson is working with governmental agencies around the world to supply fully compliant products and remove the risk of violating country directives or laws governing wireless device usage.

C.4 FCC and IC (for wireless products only)

This device complies with Part 15 of the FCC Rules. Operation is subject to the following conditions: This device may not cause harmful interference. This device must accept any interference received, including interference that may cause undesired operation. This device must be installed to ensure a minimum antenna separation distance of 20 cm from all persons.

C.5 Installing equipment in North America

The US National Electrical Code® (NEC) and the Canadian Electrical Code (CEC) permit the use of Division marked equipment in Zones and Zone marked equipment in Divisions. The markings must be suitable for the area classification, gas, and temperature class. This information is clearly defined in the respective codes.

C.6 USA

C.6.1 E5 USA Explosionproof

Certificate CSA 2174201

Standards FM Class 3600 - 2011, FM Class 3615 - 2006, ANSI/UL 61010-1 3rd Edition

Markings Class I, Division 1, Groups A, B, C and D; T5, T6; Type 4X and IP66 ($-50\text{ }^{\circ}\text{C} \leq T_a \leq +70\text{ }^{\circ}\text{C}$)

C.6.2 I5 USA Intrinsically Safe (IS) and Non-incendive

Certificate 3036224

Standards FM Class 3600 - 1998, FM Class 3610 - 2007, FM Class 3611 - 2004, FM Class 3810 - 2005, NEMA 250 - 2003, IEC 60529 - 2004

Markings IS CL I, DIV 1, GP A, B, C, D; CL II, DIV 1, GP E, F, G; Class III; Class 1, Zone 0, AEx ia IIC T4; NI CL I, DIV 2, GP A, B, C, D T4; T4($-50\text{ }^{\circ}\text{C} \leq T_a \leq +70\text{ }^{\circ}\text{C}$) when connected per Rosemount drawing 00775-0010; Type 4X/IP66

C.7 Canada

C.7.1 E6 Canada Explosionproof

Certificate CSA 2174201

Standards CAN/CSA C22.2 No. 0-M91, CSA Std. C22.2 No. 30-M1986, CAN/CSA-C22.2 No. 94-M91, CAN/CSA-C22.2 No. 61010-1-12, CSA Std. C22.2 No. 60529

Markings Class I, Division 1, Groups A, B, C and D; T5, T6; Type 4X and IP66 ($-50\text{ }^{\circ}\text{C} \leq T_a \leq +70\text{ }^{\circ}\text{C}$)

C.7.2 I6 Canada Intrinsically Safe

Certificate 2174201

Standards CAN/CSA C22.2 No. 0-M91 (R2001), CAN/CSA C22.2 No. 94-M91 (R2001), CSA Std C22.2 No. 142-M1987, CAN/CSA C22.2 No.157-92, CSA Std C22.2 No. 213-M1987, C22.2 No. 60529

Markings Intrinsically Safe Class I, Division 1, Groups A, B, C, D T3C; Suitable for use in Class I, Division 2, Groups A, B, C, D T3C; T3C($-50\text{ }^{\circ}\text{C} \leq T_a \leq +70\text{ }^{\circ}\text{C}$) when installed per Rosemount drawing 00775-0012; Type 4X/IP66

C.8 Europe

C.8.1 I1 ATEX Intrinsic Safety

Certificate Baseefa09ATEX0125X

Standards	IEC 60079-0:2011; EN60079-11:2012;
Markings	Ⓜ II 1G Ex ia IIC T4 Ga, T4(-50 °C ≤ T _a ≤ +70 °C)

Special Conditions for Safe Use (X):

1. The surface resistivity of the antenna is greater than 1GΩ. To avoid electrostatic charge build-up, it must not be rubbed or cleaned with solvents or dry cloth.
2. The Rosemount 775 enclosure may be made of aluminum alloy and given a protective polyurethane paint finish; however, care should be taken to protect it from impact or abrasion if located in zone 0.

C.8.2 N1 ATEX Type n

Certificate	Baseefa09ATEX0131
Standards	IEC 60079-0:2012 + A11:2013, EN 60079-15:2010;
Markings	Ⓜ II 3G Ex nA IIC T4 Gc, T4(-50 °C ≤ T _a ≤ +70 °C) IP66

C.9 International

C.9.1 I7 IECEX Intrinsic Safety

Certificate	IECEX BAS 09.0050X
Standards	IEC 60079-0:2011, IEC 60079-11:2011
Markings	Ex ia IIC T4 Ga, T4(-50 °C ≤ T _a ≤ +70 °C) IP66

Special Conditions for Safe Use (X):

1. The surface resistivity of the antenna is greater than 1 GΩ. To avoid electrostatic charge build-up, it must not be rubbed or cleaned with solvents or dry cloth.
2. The Rosemount 775 enclosure may be made of aluminum alloy and given a protective polyurethane paint finish; however, care should be taken to protect it from impact or abrasion if located in zone 0.

C.9.2 N7 IECEX Type n

Certificate	IECEX BAS 09.0058
Standards	IEC 60079-0:2011, IEC 60079-15:2010;
Markings	Ex nA IIC T4 Gc, T4(-50 °C ≤ T _a ≤ +70 °C) IP66

C.10 Brazil

C.10.1 I2 INMETRO Intrinsic Safety

Certificate	UL-BR 15.0089X
Standards	ABNT NBR IEC 60079-0:2013, ABNT NBR IEC 60079-11:2013

Markings Ex ia IIC T4 Ga (-50 °C ≤ T_a ≤ +70 °C), IP66

Special Conditions for Safe Use (X):

1. The surface resistivity of the antenna is greater than 1 GΩ. To avoid electrostatic charge build-up, it must not be rubbed or cleaned with solvents or dry cloth.
2. The enclosure may be made of aluminum alloy and given a protective polyurethane paint finish; special care must be taken to minimize the risk of impact or friction of the housing which can cause the generation of sparks.

C.10.2 N2 INMETRO Type n

Certificate UL-BR 15.0027

Standards ABNT NBR IEC 60079-0:2008 + Errata 1:2011, IEC 60079-15:2012

Markings Ex nA IIC T4 Gc (-50 °C ≤ T_a ≤ +70 °C) IP66

C.11 China

C.11.1 I3 NEPSI Intrinsic Safety

Certificate: GYJ20.1388X

Standards: GB3836.1 – 2010, GB3836.4 – 2010, GB3836.20-2010

Markings: Ex ia IIC T4 Ga, -50 ~ +70 °C

Special Conditions for Safe Use (X):

1. See certificate for special conditions.

C.12 Japan

C.12.1 I4 CML Intrinsically Safe

Certificate CML19JPN2107X

Markings Ex ia IIC T4 Ga, -50 °C ~ +70 °C

Special Conditions for Safe Use (X):

1. See certificate for special conditions.

C.13 EAC - Belarus, Kazakhstan, Russia

C.13.1 IM Technical Regulation Customs Union (EAC) Intrinsic Safety

Certificate TC RU C-US.AA87.B.00993

Markings 0Ex ia IIC T4 Ga X; T4 (-50 °C ≤ T_a ≤ +70 °C) IP66

Special Conditions for Safe Use (X):

1. See certificate for special conditions.

C.13.2 NM Technical Regulation Customs Union (EAC) Type n

Certificate TC RU C-US.AA87.B.00993

Markings 2Ex nA IIC T4 Gc X; T4 (-50 °C ≤ T_a ≤ +70 °C) IP66

Special Conditions for Safe Use (X):

1. See certificate for special conditions.

C.14 Republic of Korea

C.14.1 IP Korea (KOSHA) Intrinsic Safety

Certificate 10-KB4BO-0010X

Markings Ex ia IIC T4

Special Conditions for Safe Use (X):

1. See certificate for special conditions.

C.15 India

C.15.1 IW India (CCOE) Intrinsic Safety

Certificates A/P/HQ/MH/104/4259(P366317)

Markings Ex ia IIC T4

C.16 Combinations

KM Combination of IM and NM

D Ordering Information



D.1 Online product configurator

Many products are configurable online using our Product Configurator. Select the **Configure** button or visit our [website](#) to start. With this tool's built-in logic and continuous validation, you can configure your products more quickly and accurately.

D.2 Specifications and options

See the Specifications and options section for more details on each configuration. Specification and selection of product materials, options, or components must be made by the purchaser of the equipment. See the Material selection section for more information.

D.3 Model codes

Model codes contain the details related to each product. Exact model codes will vary; an example of a typical model code is shown in [Figure D-1](#).

Figure D-1: Model Code Example

775XD11I5 WA3WK9
1 2

1. Required model components (choices available on most)
2. Additional options (variety of features and functions that may be added to products)

D.4 Optimizing lead time

The starred offerings (★) represent the most common options and should be selected for the fastest delivery times. The nonstarred offerings are subject to additional delivery lead time.

D.5 Required model components

D.6 Model

Requires THUM Connection Box.

Code	Description
775TG	Wireless 775 THUM Adapter Assembly Tank Gauging

D.7 Output

Code	Description	
X	Wireless	

D.8 Housing

Code	Description	
D	Aluminum	★
E	SST	

D.9 Mounting connection

Code	Description	
1	½- 14NPT	★
2	M20 conduit adapter	★

D.10 PlantWeb functionality

Code	Description	
1	HART® data	★

D.11 Certification

Code	Description	
NA	No approval	★
I1	ATEX Intrinsic Safety	★
I2	Brazil (INMETRO) Intrinsic Safety	★
I3	China (NEPSI) Intrinsic Safety	★
I4	Japan (CML) Intrinsically Safe	★
I5	USA (FM) Intrinsically Safe, Non-incendive	★
I6	Canada (CSA) Intrinsically Safe	★
I7	IECEX Intrinsically Safe	★
N1	ATEX Type n	★
N2	Brazil (INMETRO) Type n	★
N7	IECEX Type n	★
IP	Korea (KOSHA) Intrinsic Safety	★
IW	India (CCOE) Intrinsic Safety	★
IM	Technical Regulations Customs Union (EAC) Intrinsic Safety	★
NM	Technical Regulation Customs Union (EAC) Type n	
KM	Technical Regulation Customs Union (EAC) Intrinsic Safety and Type n	
E5	USA Explosion proof	
E6	Canada Explosion proof	

D.12 Wireless update rate, operating frequency, and protocol

Code	Description	
WA3	User-configurable update rate, 2.4 GHz DSSS, IEC 62591 (<i>WirelessHART</i> ®)	★

D.13 Omni-directional antenna and SmartPower™ solutions

Code	Description	
WK9	Long range, integral antenna, power scavenging	★

D.14 Accessories

Item description	Part Number
Remote mount kit - aluminum	00775-9000-0001
Remote mount kit - stainless steel	00775-9000-0011

Item description	Part Number
M20 conduit adapter	00775-9001-0001

E Dimensional drawings

Figure E-1: THUM Adapter FM I.S. & Class 1, Div. 2 Installation Drawing (1 of 2)

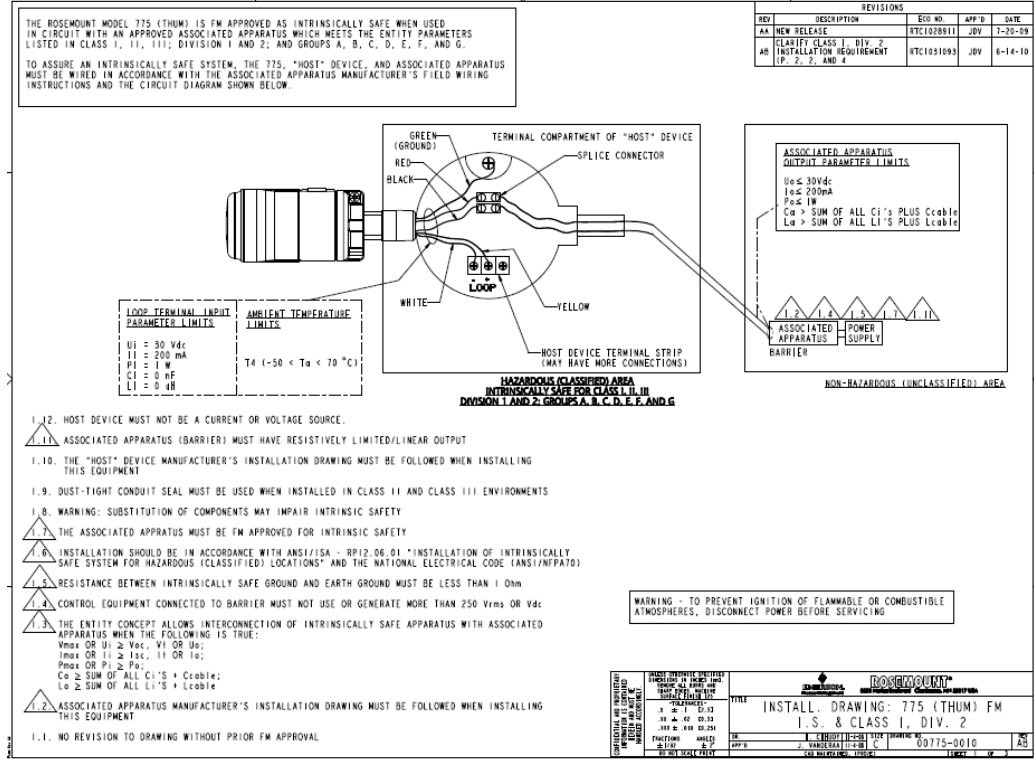

Figure E-2: THUM Adapter FM I.S. & Class 1, Div. 2 Installation Drawing (2 of 2)

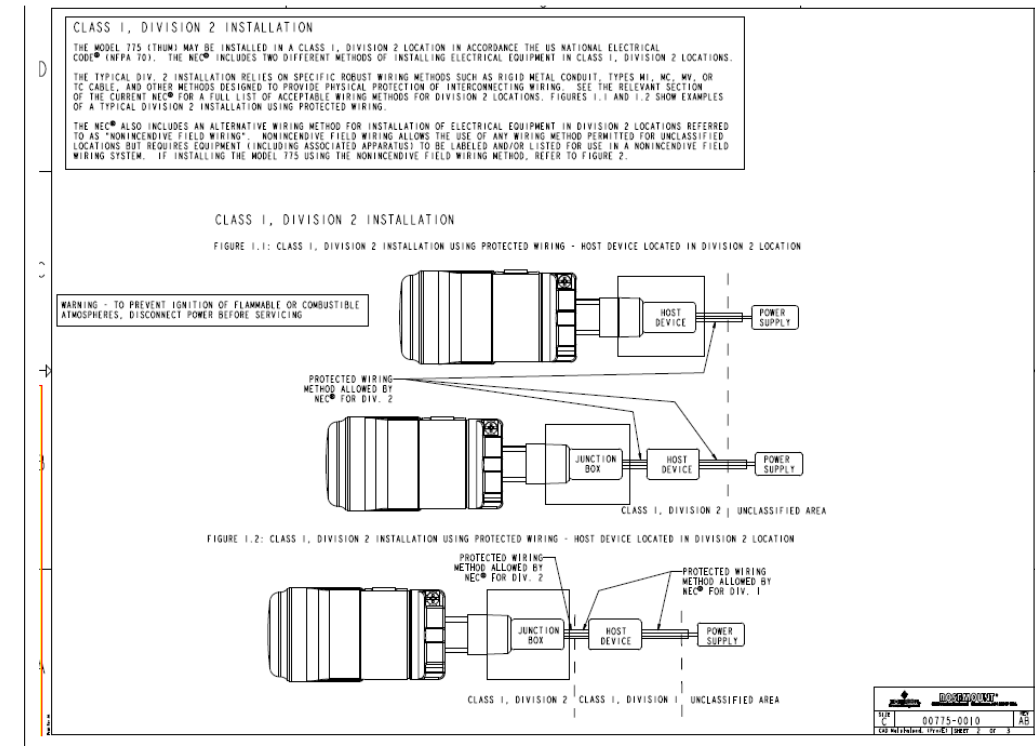

Figure E-3: THUM Adapter CSA I.S. Installation drawing

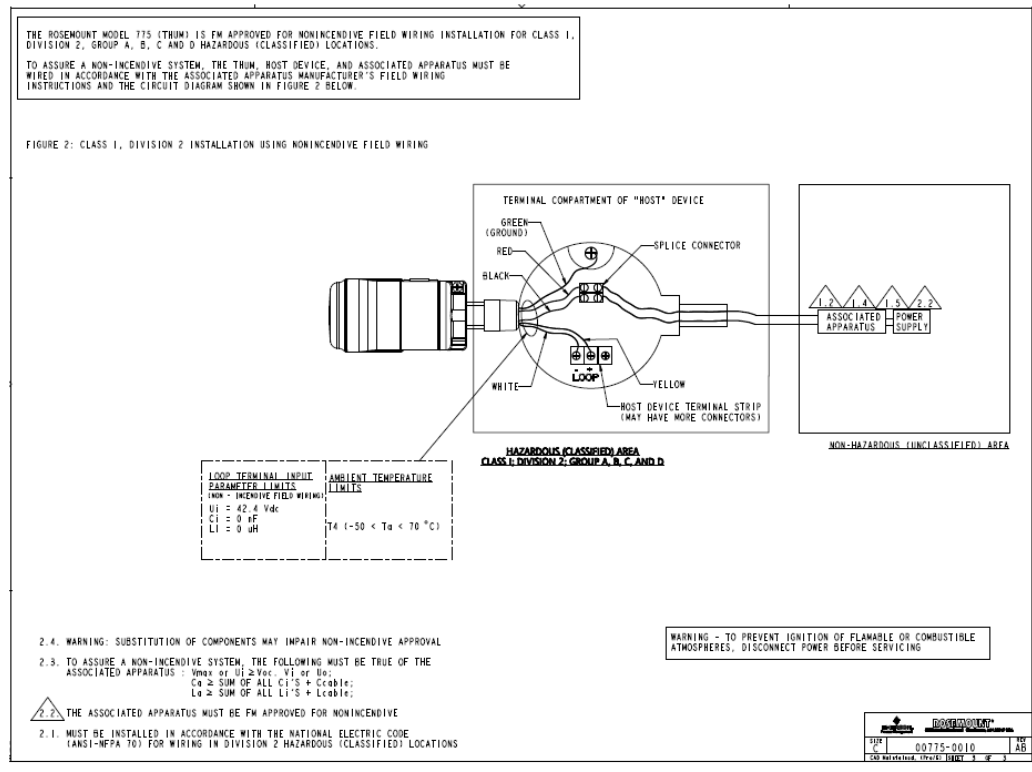
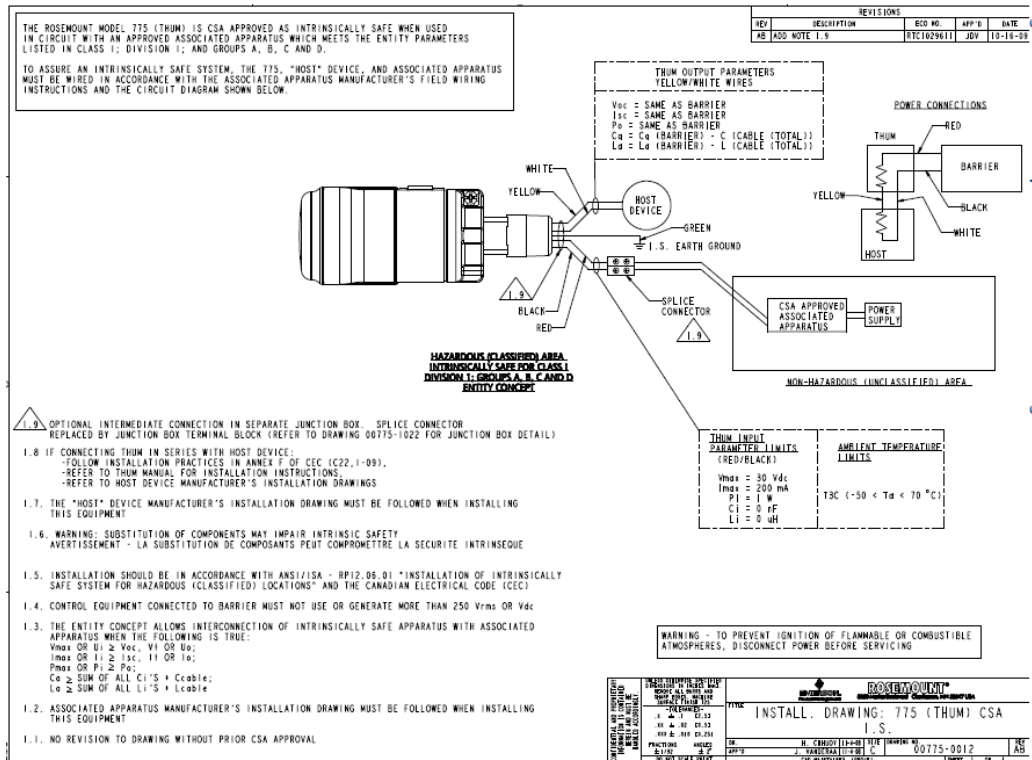

Figure E-4: THUM Adapter CSA Installation Drawing



©2023 Emerson. All rights reserved.

Emerson Terms and Conditions of Sale are available upon request. The Emerson logo is a trademark and service mark of Emerson Electric Co. Rosemount is a mark of one of the Emerson family of companies. All other marks are the property of their respective owners.