



Series 1950 Explosion-Proof Differential Pressure Switches

Specifications - Installation and Operating Instructions



UL and CSA Listed, FM Approved For
CL. I GR. C, D - CL. II GR. E, F, G - CL. III

Series 1950 Switches

Operating ranges and deadbands

To order specify Model Number	Operating Range: Inches, W.C.	Approximate Dead Band	
		At Min. Set Point	At Max. Set Point
1950-02-2S	0.03 to 0.10	0.025	0.05
1950-00-2F	0.07 to 0.15	0.04	0.05
1950-0-2F	0.15 to 0.5	0.10	0.15
1950-1-2F	0.4 to 1.6	0.15	0.20
1950-5-2F	1.4 to 5.5	0.3	0.4
1950-10-2F	3.0 to 11.0	0.4	0.5
1950-20-2F	4.0 to 20.0	0.4	0.6

Model Number	Operating Range: PSI	Approximate Dead Band	
		Min. Set Point	Max. Set Point
1950P-2-2F	0.5 to 2.0	0.3 psi	0.3 psi
1950P-8-2F	1.5 to 8.0	1.0 psi	1.0 psi
1950P-15-2F	3.0 to 15.0	0.9 psi	0.9 psi
1950P-25-2F	4.0 to 25.0	0.7 psi	0.7 psi
1950P-50-2F	15.0 to 50	1.0 psi	1.5 psi

Series 1950 Explosion-Proof Differential Pressure Switches combine the best features of the Series 1900 Pressure Switch with an integral explosion-proof and weather-proof housing. Each unit is UL & CSA listed; FM approved for use in Class I, Groups C & D; Class II, Groups E, F, & G; and Class III atmospheres (NEMA 7 & 9). They are totally rain-tight for outdoor installations. Twelve models allow set-points from .03 to 20 inches w.c. and from .5 to 50 psi (3.4 to 345 kPa).

Easy access to the SPDT switch for electrical hook-up is provided by removing the top plate of the three-part aluminum housing. Adjustment to the set point of the switch can be made without disassembling the housing. The unit is very compact, about half the weight and bulk of equivalent conventional explosion-proof switches.

CAUTION

For use only with air or compatible gases. Use of the Model 1950 switch with explosive media connected to the Low pressure port (including differential pressure applications in such media) is not recommended. Switch contact arcing can cause an explosion inside the switch housing which, while contained, may render the switch inoperative. If switch is being used to sense a single positive pressure relative to atmosphere, run a line from the low pressure port to a non-hazardous area free of combustible gases. This may increase response time on -0 and -00 models.

Note: The last number-letter combination in the model number identifies the switch's electrical rating (number) and diaphragm material (letter). The 2F combination is standard as described in the physical data above. In case of special models, a number 1 rating is the same as 2; a number 3 or 4 rating is 10A 125, 250, 480 VAC; 1/8 H.P. 125 VAC; 1/4 H.P. 250 VAC; a number 5 or 6 rating is 1A 125 VAC. Letter B indicates a Buna-N diaphragm; N = Neoprene; S = Silicone; and V = Viton®.

SPECIFICATIONS

Service: Air and non-combustible, compatible gases.

Wetted Materials: Consult factory.

Temperature Limits: -40 to 140°F (-40 to 60°C); 0 to 140°F (-17.8 to 60°C) for 1950P-8, 15, 25, and 50. -30 to 130°F (-34.4 to 54.4°C) for 1950-02.

Pressure Limits:

Continuous: 1950's - 45" w.c. (0.11 bar);

1950P's - 35 psi (2.41 bar); 1950P-50 only - 70 psi (4.83 bar).

Surge: 1950's - 10 psi (0.69 bar), 1950P's - 50 psi (3.45 bar), 1950P-50 only - 90 psi (6.21 bar).

Enclosure Rating: IP54, NEMA 3, 7 and 9.

Switch Type: Single-pole double-throw (SPDT).

Electrical Rating: 15 A @, 125, 250, 480 VAC, 60 Hz. Resistive 1/8 HP @ 125 VAC, 1/4 HP @ 250 VAC, 60 Hz.

Electrical Connections: 3 screw type, common, normally open and normally closed.

Process Connections: 1/8" female NPT.

Mounting Orientation: Diaphragm in vertical position. Consult factory for other position orientations.

Set Point Adjustment: Screw type on top of housing.

Weight: 3.25 lb (1.5 kg); 1950-02 model, 4.4 lb (2 kg).

Agency Approvals: CE, UL, CSA, FM.

RESPONSE TIME: Because of restrictive effect of flame arrestors, switch response time may be as much as 10-25 seconds where applied pressures are near set point.

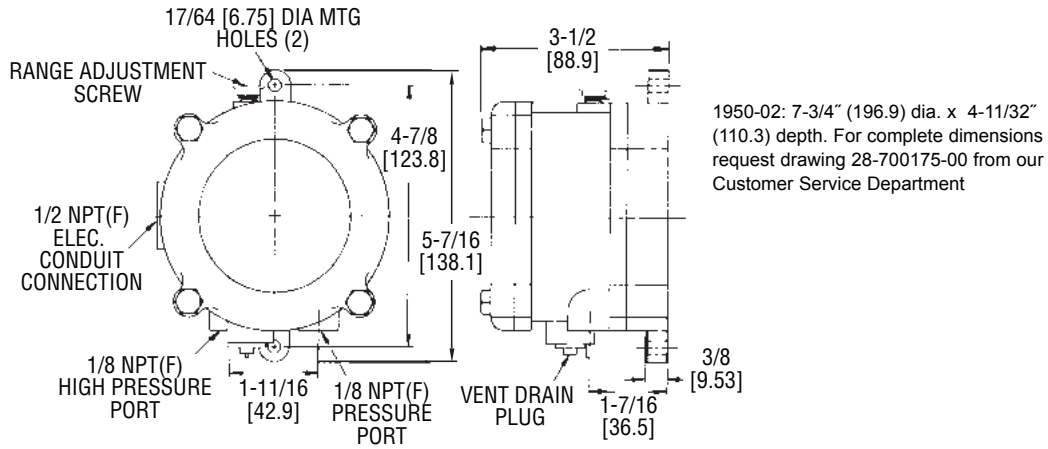

1950-02: 7-3/4" (196.9) dia. x 4-11/32" (110.3) depth. For complete dimensions request drawing 28-700175-00 from our Customer Service Department

1950 Switch Outline Dimensions

INSTALLATION

1. Select a location free from excess vibration and corrosive atmospheres where temperatures will be within the limits noted under Specifications on reverse. Switch may be installed outdoors or in areas where the hazard of explosion exists. See reverse for specific types of hazardous service.

2. Mount standard switches with the diaphragm in a vertical plane and with switch lettering and nameplate in an upright position. Some switches are position sensitive and may not reset properly unless they are mounted with the diaphragm vertical.

3. Connect switch to source of pressure, vacuum or differential pressure. Metal tubing with 1/4" O.D. is recommended, but any tubing which will not restrict the air flow can be used. Connect to the two 1/8" female NPT pressure ports as noted below:

A. Differential pressures - connect pipes or tubes from source of greater pressure to high pressure port marked HIGH PRESS, and from source of lower pressure to low pressure port marked LOW PRESS.

B. Pressure only (above atmospheric pressure) - connect tube from source of pressure to high pressure port. The low pressure port is left open to atmosphere.

C. Vacuum only (below atmospheric pressure) - connect tube from source of vacuum to low pressure port. The high pressure port is left open to atmosphere.

4. To make electrical connections, remove the three hex head screws from the cover and after loosening the fourth captive screw, swing the cover aside. Electrical connections to the standard single pole, double throw snap switch are provided by means of terminals marked "COM" (common), "NO" (norm open), "NC" (norm closed). The normally open contacts close and the normally closed contacts open when pressure increases beyond the set point. Switch loads for standard models should not exceed the maximum specified current rating of 15 amps resistive. Switch capabilities decrease with an increase in ambient temperature, load inductance, or cycling rate. Whenever an application involves one or more of these factors, the user may find it desirable to limit the switched current to 10 amps or less in the interest of prolonging switch life.

ADJUSTMENT: To Change the Set point

1. Remove the plastic cap and turn the slotted Adjust-ment Screw at the top of the housing clockwise to raise the set point pressure and counter-clockwise to lower the set point. After calibration, replace the plastic cap and re-check the set point.

2. The recommended procedure for calibrating or checking calibration is to use a "T" assembly with three rubber tubing leads, all as short as possible and the entire assembly offering minimum flow restriction. Run one lead to the pressure switch, another to a manometer of known accuracy and appropriate range, and apply pressure through the third tube. Make final approach to the set point very slowly. Note that manometer and pressure switch will have different response times due to different internal volumes, lengths of tubing, fluid drainage, etc. Be certain the switch is checked in the position it will assume in use, i.e. with diaphragm in a vertical plane and switch lettering and Dwyer nameplate in an upright position.

3. For highly critical applications check the set point adjustment and if necessary, reset it as noted in step A.

MAINTENANCE

The moving parts of these switches need no maintenance or lubrication. The only adjustment is that of the set point. Care should be taken to keep the switch reasonably clean. Periodically the vent drain plug should be rotated, then returned to its original position. This will dislodge deposits which could accumulate in applications where there is excessive condensation within the switch. The Series 1950 Explosion-Proof Differential Pressure Switch is not field serviceable and should be returned if repair is needed (field repair should not be attempted and may void warranty). Be sure to include a brief description of the problem plus any relevant application notes. Contact customer service to receive a return goods authorization number before shipping.