

June 1986

## Single and Second-Stage LP-Gas Regulators



### WARNING

Fisher equipment must be installed, operated, and maintained in accordance with federal, state, and local codes and Fisher instructions. The installation in most states must also comply with NFPA No. 54 and 58 standards.

Only personnel trained in the proper procedures, codes, standards, and regulations of the LP-gas industry should install and service this equipment. Failure to follow these instructions or to properly install and maintain this equipment could result in an explosion and/or fire causing property damage and personal injury or death.

### Things To Tell The Gas Customer:

1. Point out the regulator's vent to the customer (or vent assembly or vent tube), and **stress that this opening must remain unobstructed at all times**. Tell the customer to be sure to check the vent opening after a freezing rain, sleet storm, or snow to make sure ice has not formed in the vent.
2. Show the customer the shutoff valve on the container. The customer should close this valve immediately if gas can be smelled, appliance pilot lights fail to stay on or appear higher than usual, or any other abnormal situation occurs.
3. Tell the customer to call your company to service the regulator. If the regulator vents gas or leak develops in the system, only qualified gas serviceman should install or service the regulator.

## Introduction

### Scope of Manual

This instruction manual covers installation and maintenance for the following single and second-stage LP-gas regulators: Types 912, R322 (integral two-stage), R352, R722, **R922**, R932, and S102L.

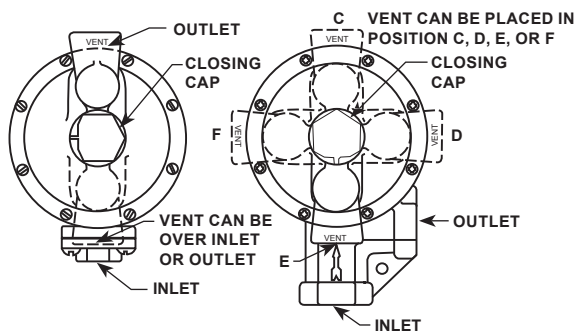

Figure 1. Typical Regulator Configurations

## Description

All the regulators are designed for low pressure (inches of water column) vapor service and are not to be used for liquid service. Their **outlet pressure** setting is usually 11-inches w.c. (27 mbar).

Single-stage regulators (reducing container pressure to 11-inches w.c. (27 mbar)) are normally painted gray while second-stage regulators (reducing the outlet of a first-stage regulator to 11-inches w.c. (27 mbar)) are normally painted palm green. The units differ in construction and capacity rating.

## Specifications

The Specifications Table lists the specifications for the regulators. Contact the factory if the regulators are to be used on any service other than LP-gas, natural gas, or air. Temperature limits are -20° to 160° F (-29° to 71° C). Second-stage regulators are limited to 20 psig (1,4 bar) inlet pressure and must be used with a first-stage regulator.

## Installation



### WARNING

All vents should be kept open to permit free flow of air into and out of the regulator. Protect openings against the entrance of rain, snow, ice formation, paint, mud, insects, or any other foreign material that could plug the vent of vent line.



# Low Pressure Regulators

## Specifications

| TYPE NUMBER | SIZE, INCH FNPT    |                   | TYPE OF SERVICE    | MAXIMUM INLET PRESSURE, PSIG (bar) | VAPOR CAPACITY, BTU/HR. PROPANE |
|-------------|--------------------|-------------------|--------------------|------------------------------------|---------------------------------|
|             | INLET CONNECTION   | OUTLET CONNECTION |                    |                                    |                                 |
| 912†        | 1/4                | 1/4 or 3/8        | Single-Stage       | 250 (17,2)                         | 350,000*                        |
| R322        | 1/4                | 1/2 or 3/4        | Integral Two-Stage | 250 (17,2)                         | 660,000                         |
| R352        | 3/4                | 3/4               | Second-Stage       | 20 (1,38)                          | 1,250,000                       |
| R722        | 3/4 or F. POL      | 3/4               | Single-Stage       | 250 (17,2)                         | 4,250,000                       |
|             | 3/4                | 3/4               | Second-Stage       | 20 (1,38)                          | 2,500,000                       |
| R922        | 1/4, 1/2 or F. POL | 1/2 or 3/4        | Single-Stage       | 250 (17,2)                         | 725,000#                        |
|             | 1/2                | 1/2 or 3/4        | Second-Stage       | 20 (1,38)                          | 750,000                         |
| R932        | 3/4 or F. POL      | 3/4               | Single-Stage       | 250 (17,2)                         | 1,200,000                       |
|             | 1/2                | 3/4               | Second-Stage       | 20 (1,38)                          | 1,250,000                       |
| S102L       | 3/4 – 1-1/2        | 3/4 – 1-1/2       | Second-Stage       | 20 (1,38)                          | 2,000,000                       |

\*320,000 BTU/Hr. with pigtails

#437,500 BTU/Hr. with pigtails

†Vent not normally tapped for vent tubing

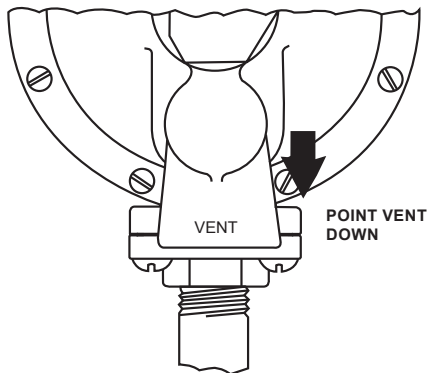

Figure 2. Point Vent Down on Outdoor Installations

LP-gas may discharge to the atmosphere through the vent. An obstructed vent which limits air or gas flow can cause abnormally high pressure that could result in personal injury or property damage. Failure to use a vent line on indoor installations can cause a hazardous accumulation of gas which could result in personal injury or property damage.

Never use a first-stage (pounds to pounds) regulator on low pressure (inches of water column) service because personal injury or property damage could occur.

Make sure gas flow through the regulator is in the same direction as the arrow on the body – "Inlet" and "Outlet" connections are clearly marked. The installation should be adequately protected from vehicular traffic and damage from other external sources. Install the regulator so that any gas discharge through the vent or vent assembly is over 3-feet (0,91 meters) horizontally from any building opening below the level of the discharge.

Install the regulator high enough above ground level – at least 18-inches (457 mm) – so that rain splatter cannot freeze in the

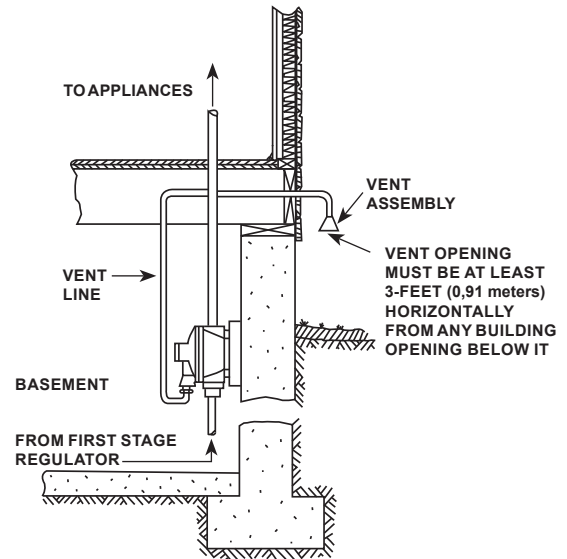

Figure 3. Typical Indoor Installation With Vent Line and Vent Assembly

vent. Whether a protective hood is used or not, do not install the regulator in a location where there can be excessive water accumulation or ice formation, such as directly beneath a down spout, gutter, or roof line of a building.

A regulator installed outdoors without a protective hood must have its vent pointed vertically down, see figure 2, to allow condensate to drain. This minimizes the possibility of freezing and of water or other foreign material entering the vent and interfering with proper operation.

Before installing the regulator, check for damage which might have occurred in shipment. Also check for and remove any dirt or foreign matter which may have accumulated in the regulator body or the pipeline. Apply pipe compound to the male threads of the pipe.

Some installations, such as in areas with heavy snow fall or on recreational vehicles where there is road splatter,

# Low Pressure Regulators

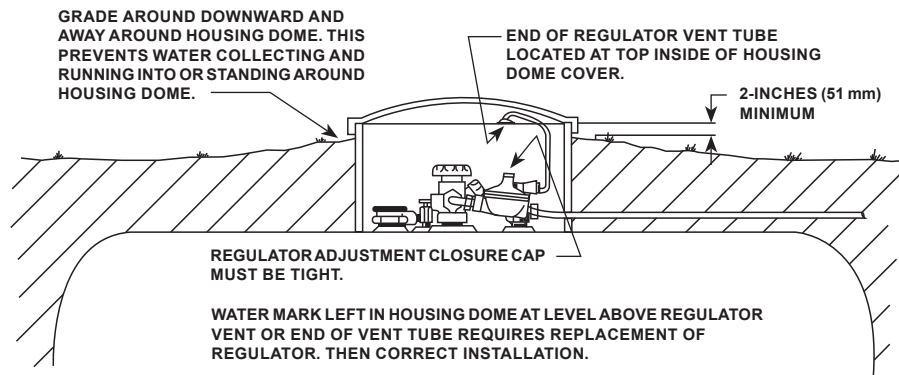

**Figure 4.** Regulators Installed on Underground Installations Require a Vent Tube

may require a hood or enclosure to protect the regulator. Horizontally mounted regulators, such as found on single cylinder installations, must be installed beneath a protective cover. If possible slope or turn the vent down sufficiently to allow any condensation to drain out of the spring case. Be careful that the slot in the hood or cover for the regulator's outlet piping does not extend too far and expose the vent to the elements.

Regulators installed indoors are limited to 20 psig (1,38 bar) maximum inlet pressure, and they require a vent line to the outside of the building, see figure 3. A vent assembly, such as Fisher Y602 series, should be used on the end of the vent line. The same installation precautions apply to vent assemblies as the integral regulator vents covered previously. Use pipe or tubing equal in size to the regulator's vent for the vent line. To install the vent line, remove the vent screen and apply a good grade of pipe dope to the male threads of the line. Vent piping or tubing must not restrict the flow passage of the regulator's internal relief valve.

Underground container systems require a vent tube to prevent water from entering the regulator spring case, see figure 4. Remove the vent screen and install the vent tube, such as a Fisher Type P203. The vent tube must be run from the regulator vent to above the maximum water table. The vent tube opening must terminate at the extreme top inside of the dome cover. Make sure the regulator's closing cap is on tightly, and maintain drainage away from the dome at all times. For further information on underground installations, write for a copy of "Underground LP-Gas Systems: Suggested Installation, Inspection," available from the National LP-Gas Association, 1301 W. 22nd St., Oak Brook, IL 60521.

## Adjustment

Each regulator is individually factory set to deliver 11-inches w.c (27 mbar). If it becomes necessary to increase the outlet pressure, remove the closing cap, figure 1, and turn the adjusting screw clockwise. Turn the adjusting screw counterclockwise to decrease the outlet pressure. A pressure gauge or water manometer is needed to determine the regulator's outlet setting after adjustment. Always replace the closing cap after adjustment.

## Overpressure Protection

### WARNING

**Personal injury or system damage may result if these regulators are installed without appropriate overpressure protection. Outlet pressures greater than 3 psig (0,20 bar) above the set point may cause damage to regulator parts, leaks in the regulator, or personal injury due to bursting of pressure-containing parts or explosion of accumulated gas.**

**If the regulator is exposed to an overpressure condition, it must be inspected for any damage that may have occurred.**

**Large volumes of gas may discharge through the regulator vent during internal relief valve operation which can result in fire or explosion from accumulated gas.**

All of the regulators have an internal relief valve that opens when downstream pressure reaches approximately 1 psig (0,069 bar) on regulators set at 11-inches w.c. (27 mbar). When the internal relief valve opens, gas escapes to the atmosphere through the regulator's vent. The internal relief valve gives overpressure protection against excessive build-up resulting from seat leakage due to worn parts or chips of foreign material on the orifice.

Some type of external overpressure protection must be provided if inlet pressure will be high enough to damage downstream equipment. Common methods of external overpressure protection include relief valves, see figure 5, monitoring regulators, shutoff devices, and series regulation. The internal relief valve on second-stage and integral two-stage regulators with the 3/4-inch (19 mm) vent (Types R322, R352, and R922) limits downstream pressure to 2 psig (0,14 bar) as long as inlet pressure does not exceed 20 psig (1,38 bar) and the vent is unobstructed.

# Low Pressure Regulators

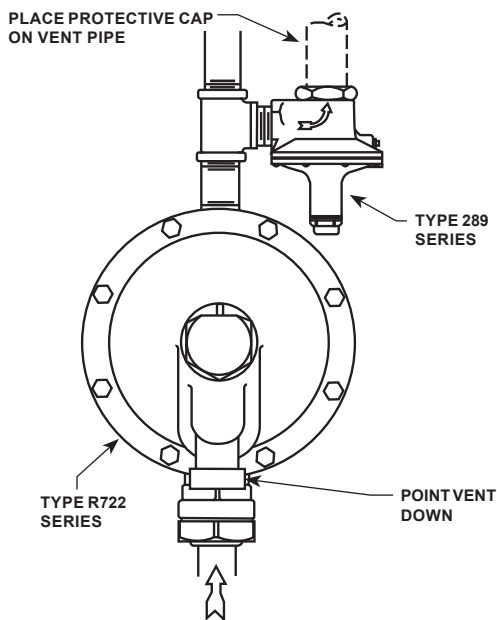

Figure 5. External Relief Valve Protects Downstream System

## Maintenance



### WARNING

To avoid personal injury or equipment damage, do not attempt any maintenance or disassembly without first isolating the regulator from system pressure and relieving all internal pressure.

Regulators that have been disassembled for repair must be tested for proper operation before being returned to service. Only parts manufactured by Fisher should be used for repairing Fisher regulators. Relight pilot lights according to normal startup procedures.

Due to normal wear or damage that may occur from external sources, these regulators must be inspected and maintained periodically. The frequency of inspection and replacement of the regulators depends upon the severity of service conditions or the requirements of

local, state, and federal regulations. Even under ideal conditions, these regulators should be replaced after 15 years from the date of manufacture or sooner should inspection reveal the need.

Visually inspect the regulator each time a gas delivery is made for:

1. Improper installation.
2. Plugged or frozen vent.
3. Wrong regulator or no regulator in the system.
4. Internal or external corrosion.
5. Age of the regulator.
6. Any other condition that could cause the uncontrolled escape of gas.

Failure to do the above could result in personal injury or property damage.

Make sure the regulator vent, vent assembly, or vent tube does not become plugged by mud, insects, ice, snow, paint, etc. The vent screen aids in keeping the vent from becoming plugged, and the screen should be clean and properly installed.

Replace any regulators that have had water in their spring case or show evidence of external or internal corrosion. Checking for internal corrosion may require complete removal of the adjusting screw and shut down of the gas system. Closely examine regulators directly connected to the container valve by means of a solid POL adaptor (horizontal mounting) for signs of corrosion. Correct any improper installations.

Older regulators are more likely to catastrophically fail because of worn or corroded parts. Replace regulators over 15 years of age; other service or environmental conditions may dictate replacement of the regulator before it becomes 15 years old, refer to Fisher Bulletin LP-32.

## Regulator Repair

Regulators that have been disassembled for repair must be tested for proper operation before being returned to service. Fisher Type Y499-2 test rack can be furnished for this purpose. Only parts manufactured by Fisher should be used for the repair of Fisher regulators. Be sure to give the complete type number of the regulator when corresponding with the factory.

Fisher and Fisher Regulators are marks owned by Fisher Controls International, LLC. The Emerson logo is a trademark and service mark of Emerson Electric Co. All other marks are the property of their respective owners.

The contents of this publication are presented for informational purposes only, and while every effort has been made to ensure their accuracy, they are not to be construed as warranties or guarantees, expressed or implied, regarding the products or services described herein or their use or applicability. We reserve the right to modify or improve the designs or specifications of such products at any time without notice.

Fisher does not assume responsibility for the selection, use or maintenance of any product. Responsibility for proper selection, use and maintenance of any Fisher product remains solely with the purchaser.

### Emerson Process Management

Fisher Controls International, LLC.  
P.O. Box 8004  
McKinney, Texas 75070, USA  
Telephone: 1 (800) 588-5853  
Telephone: 1 (469) 293-4201