

## Diaphragm Valve, Metal

### Construction

The GEMÜ 650 piston actuated 2/2-way diaphragm valve is designed for use in sterile areas of application.

All metallic actuator components are made of stainless steel. The compression springs of diaphragm sizes 80 and 100 are made of epoxy coated spring steel. Normally closed, Normally open and Double acting control functions are available. The valve has an optical position indicator as standard.

### Features

- Suitable for inert and corrosive\* liquid and gaseous media
- Valve body and diaphragm available in various materials and designs
- Compact design (ideal when space is at a premium)
- Various connections available
- CIP/SIP and sterilizing capabilities
- Autoclave capability, dependent on version
- Surface finishes down to  $Ra \leq 0.25 \mu m$ , electropolished
- Versions according to ATEX on request

### Advantages

- Hermetic separation between medium and actuator
- Optional flow direction
- Installation for an optimized draining is possible
- Control air connectors positioned in-line with piping (option: 90° offset)
- Expelled air from spring chamber can optionally be piped to other locations
- Extensive range of accessories, easily retrofitted

\* see information on working medium on page 2



Actuator version "T"



Actuator version "D"

### Sectional view

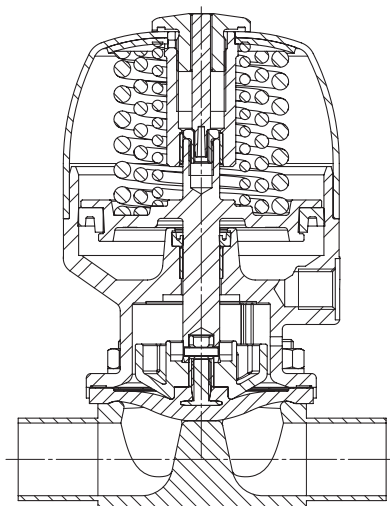

DN 100 „T“

## Technical data

### Working medium

Corrosive, inert, gaseous and liquid media which have no negative impact on the physical and chemical properties of the body and diaphragm material.

The valve will seal in both flow directions up to full operating pressure (gauge pressure).

### Temperatures

**Medium temperature** -10 to 100 °C

#### Sterilisation temperature <sup>(1)</sup>

EPDM (code 13/3A)	max. 150 °C <sup>(2)</sup> , max. 60 min per cycle
EPDM (code 17)	max. 150 °C <sup>(2)</sup> , max. 180 min per cycle
EPDM (code 19)	max. 150 °C <sup>(2)</sup> , max. 180 min per cycle
PTFE/EPDM (code 54)	max. 150 °C <sup>(2)</sup> , no time limit per cycle
PTFE/EPDM (code 5M, 5Q)	max. 150 °C <sup>(2)</sup> , no time limit per cycle
PTFE/PVDF/EPDM (code 71)	not applicable

<sup>1</sup> The sterilisation temperature is valid for steam (saturated steam) or superheated water.

<sup>2</sup> If the sterilisation temperatures listed above are applied to the EPDM diaphragms for longer periods of time, the service life of the diaphragms will be reduced. In these cases, maintenance cycles must be adapted accordingly.

This also applies to PTFE diaphragms exposed to high temperature fluctuations.

PTFE diaphragms can also be used as steam barriers; however, this will reduce their service life.

The maintenance cycles must be adapted accordingly.

GEMÜ 555 and 505 globe valves are particularly suitable for use in the area of steam generation and distribution.

The following valve arrangement for interfaces between steam pipes and process pipes has proven itself over time:

A globe valve for shutting off steam pipes and a diaphragm valve as an interface to the process pipes.

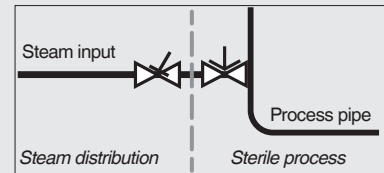

**Ambient temperature**

0 ... 60 °C

### Control medium

#### Inert gases

**Max. permissible temperature of control medium**

60 °C

#### Filling volume

Diaphragm size	DN	Actuator size	Actuator version	Spring set	Control function 1	Control function 2
8	4 to 15	0	T/R	1	0.01 dm <sup>3</sup>	0.01 dm <sup>3</sup>
			T/R	A	0.02 dm <sup>3</sup>	0.01 dm <sup>3</sup>
10	10 to 20	1	T/R/D/B	1	0.03 dm <sup>3</sup>	0.07 dm <sup>3</sup>
25	15 to 25	2	T/R/D/B	1	0.13 dm <sup>3</sup>	0.22 dm <sup>3</sup>
			T/R/D/B	1	0.23 dm <sup>3</sup>	0.50 dm <sup>3</sup>
40	32 to 40	3	T/R	A	0.50 dm <sup>3</sup>	-
			T/R/D/B	1	0.50 dm <sup>3</sup>	1.20 dm <sup>3</sup>
50	50 to 65	4	T/R/D/B	1	2.68 dm <sup>3</sup>	3.20 dm <sup>3</sup>
80	65 to 80	5	T/R	A/B	2.13 dm <sup>3</sup>	-
			T/R	1	2.78 dm <sup>3</sup>	3.40 dm <sup>3</sup>
100	100	6	T/R	A	2.15 dm <sup>3</sup>	-
			T	A	5.30 dm <sup>3</sup>	-

C.f. 3 = for filling volume in open position see c.f. 1;

for filling volume in closed position see c.f. 2

## Technical data

Kv values [m <sup>3</sup> /h]									
Pipe standard		DIN	EN 10357 series B (formerly DIN 11850 series 1)	EN 10357 series A (formerly DIN 11850 series 2) / DIN 11866 series A	DIN 11850 Series 3	SMS 3008	ASME BPE / DIN 11866 series C	ISO 1127 / EN 10357 series C / DIN 11866 series B	DIN ISO 228
Connection code		0	16	17	18	37	59	60	1
MG	DN								
8	4	0.5	-	-	-	-	-	-	-
	6	-	-	1.1	-	-	-	1.2	-
	8	-	-	1.3	-	-	0.6	2.2	1.4
	10	-	2.1	2.1	2.1	-	1.3	-	-
	15	-	-	-	-	-	2.0	-	-
10	10	-	2.4	2.4	2.4	-	2.2	3.3	-
	12	-	-	-	-	-	-	-	3.2
	15	3.3	3.8	3.8	3.8	-	2.2	4.0	3.4
	20	-	-	-	-	-	3.8	-	-
25	15	4.1	4.7	4.7	4.7	-	-	7.4	6.5
	20	6.3	7.0	7.0	7.0	-	4.4	13.2	10.0
	25	13.9	15.0	15.0	15.0	12.6	12.2	16.2	14.0
40	32	25.3	27.0	27.0	27.0	26.2	-	30.0	26.0
	40	29.3	30.9	30.9	30.9	30.2	29.5	32.8	33.0
50	50	46.5	48.4	48.4	48.4	51.7	50.6	55.2	60.0
	65	-	-	-	-	62.2	61.8	-	-
80	65	-	-	77.0	-	68.5	68.5	96.0	-
	80	-	-	111.0	-	80.0	87.0	111.0	-
100	100	-	-	194.0	-	173.0	188.0	214.0	-
150	150	-	-	-	-	-	570.0	-	-

MG = diaphragm size

Kv values determined acc. to DIN EN 60534, inlet pressure 5 bar,  $\Delta p$  1 bar, stainless steel valve body (forged body) and soft elastomer diaphragm. The Kv values for other product configurations (e.g. other diaphragm or body materials) may differ. In general, all diaphragms are subject to the influences of pressure, temperature, the process and their tightening torques. Therefore the Kv values may exceed the tolerance limits of the standard.

The Kv value curve (Kv value dependent on valve stroke) can vary depending on the diaphragm material and duration of use.

## Autoclavability

Actuator size 0	Standard version with autoclave capability
Actuator size 1	Standard version with autoclave capability
Actuator size 2	Standard version with autoclave capability
Actuator size 3	with special version
Actuator size 4	with special version
Actuator size 5	not possible
Actuator size 6	not possible
Actuator size 8	not possible

## Technical data

Operating pressure [bar]								
MG	DN	Control function	Actuator version	EPDM		PTFE		
				Diaphragm material	All valve body materials	Diaphragm material	Forged and block material bodies	Investment cast body
8	4 to 15	1	0T1, 0R1	3A, 17, 19	0 to 8	54	0 to 6	0 to 6
			0TA, 0RA		0 to 10		0 to 10	0 to 6
		2 + 3	0T1, 0R1, 0TA, 0RA		0 to 10		0 to 10	0 to 6
					0 to 10		0 to 10	0 to 6
10	10 to 20	1	1T1, 1R1	3A, 17, 19	0 to 10	54, 5M	0 to 10	0 to 6
			1D1, 1B1		0 to 10		0 to 6	
		2 + 3	1T1, 1R1		0 to 10		0 to 10	0 to 6
					1D1, 1B1		0 to 10	0 to 6
25	15 to 25	1	2T1, 2R1	3A, 17, 19	0 to 10	54, 5M	0 to 10	0 to 6
			2D1, 2B1		0 to 10		0 to 6	
		2 + 3	2T1, 2R1		0 to 10		0 to 10	0 to 6
					2D1, 2B1		0 to 10	0 to 6
40	32 to 40	1	3T1, 3R1, 3D1, 3B1	3A, 17, 19	0 to 10	54, 5M	0 to 6	0 to 6
			3TA, 3RA		-		0 to 10	0 to 6
		2 + 3	3T1, 3R1		0 to 10		0 to 10	0 to 6
					3D1, 3B1		0 to 10	0 to 6
50	50 to 65	1	4T1, 4R1	3A, 17, 19	0 to 10	54, 5M	0 to 10	0 to 6
			4D1, 4B1		0 to 10		0 to 6	
		2 + 3	4T1, 4R1		0 to 10		0 to 10	0 to 6
					4D1, 4B1		0 to 10	0 to 6
80	65 to 80	1	5T1, 5R1	3A, 17, 19	0 to 8	54, 5M	0 to 5	-
			5TA, 5RA		-		0 to 10	-
			5TB, 5RB		0 to 10		-	-
		2 + 3	5T1, 5R1		0 to 10		0 to 10	-
100	100	1	6T1, 6R1	3A, 17, 19	0 to 6	54, 5M	0 to 4	-
			6TA, 6RA		0 to 10		0 to 10	-
		2 + 3	6T1, 6R1		0 to 10		0 to 10	-
150	150	1	8TA, 8RA	-	-	5Q	0 to 10	-

All pressures are gauge pressures. Operating pressure values were determined with static operating pressure applied on one side of a closed valve. Sealing at the valve seat and atmospheric sealing is ensured for the given values.

Information on operating pressures applied on both sides and for high purity media on request

MG = diaphragm size

## Technical data

Control pressure [bar]				
MG	DN	Control function	Actuator version	Control pressure
8	4 to 15	1	0T1, 0R1	5.0 to 7.0
			0TA, 0RA	3.5 to 7.0
		2 + 3	0T1, 0R1	max. 5.5
			0TA, 0RA	max. 4.5
10	10 to 20	1	1T1, 1R1, 1D1, 1B1	4.5 to 7.0
		2 + 3	1T1, 1R1, 1D1, 1B1	max. 4,5
25	15 to 25	1	2T1, 2R1, 2D1, 2B1	5.0 to 7.0
		2 + 3	2T1, 2R1, 2D1, 2B1	max. 4.5
40	32 to 40	1	3T1, 3R1, 3D1, 3B1	4.5 to 7.0
			3TA, 3RA	3.5 to 7.0
		2 + 3	3T1, 3R1, 3D1, 3B1	max. 4.5
50	50 to 65	1	4T1, 4R1, 4D1, 4B1	4.5 to 7.0
		2 + 3	4T1, 4R1, 4D1, 4B1	max. 4,5
80	65 to 80	1	5T1, 5R1	3.5 to 7.0
			5TA, 5RA	4.5 to 7.0
			5TB, 5RB	4.0 to 7.0
		2 + 3	5T1, 5R1	max. 4.0
100	100	1	6T1, 6R1	3.5 to 7.0
			6TA, 6RA	5.0 to 7.0
		2 + 3	6T1, 6R1	max. 4.0
150	150	1	8TA, 8RA	7.0 to 8.0

MG = diaphragm size

## Technical data

### Control pressure / operating pressure diagram

Control function 2 + 3  
with elastomer diaphragm  
Diaphragm size 8 - 25

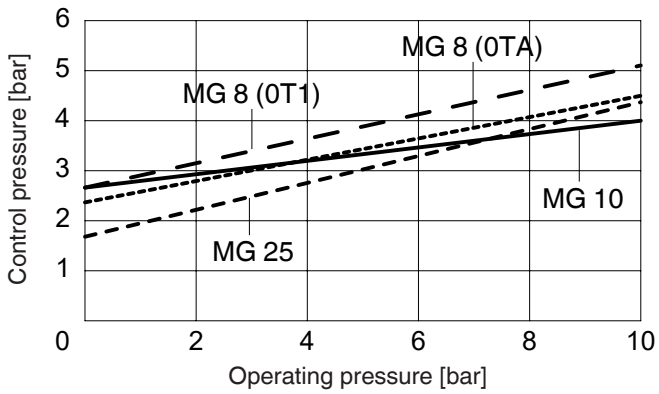

Control function 2 + 3  
with elastomer diaphragm  
Diaphragm size 40 - 100

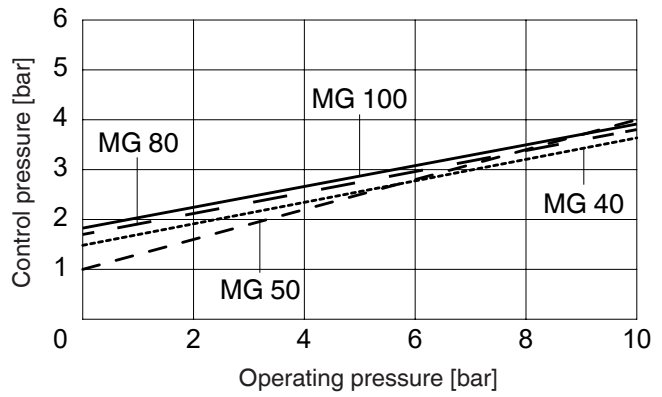

Control function 2 + 3  
with PTFE diaphragm  
Diaphragm size 8 - 25

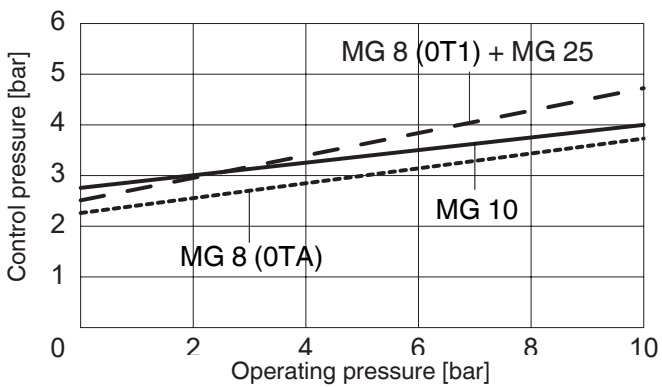

Control function 2 + 3  
with PTFE diaphragm  
Diaphragm size 40 - 100

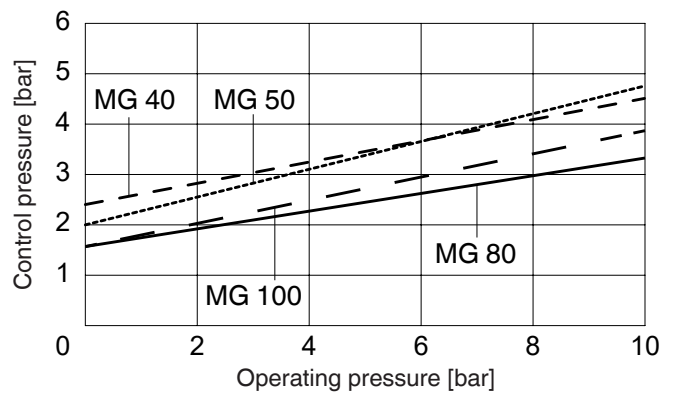

The control pressure depending on the prevailing operating pressure, as shown in the diagram, is intended as a guide for operating the system with low wear on the diaphragm.

## Order data (2/2-way valves)

Body configuration	Code
Tank bottom valve body (actuator version T)	B**
2/2-way body (actuator version D and T)	D
T body (actuator version T)	T*
* For dimensions see T Valves brochure	
** Dimensions and versions on request	

Connection	Code
<b>Butt weld spigots</b>	
Spigots DIN	0
Spigots EN 10357 series B (formerly DIN 11850 series 1)	16
Spigot EN 10357 series A (formerly DIN 11850 series 2) / DIN 11866 series A	17
Spigots DIN 11850 series 3	18
Spigots JIS-G 3447	35
Spigots JIS-G 3459	36
Spigots SMS 3008	37
Spigots BS 4825 Part 1	55
Spigot ASME BPE / DIN 11866 series C	59
Spigot ISO 1127 / EN 10357 series C / DIN 11866 series B	60
Spigots ANSI/ASME B36.19M Schedule 10s	63
Spigots ANSI/ASME B36.19M Schedule 5s	64
Spigots ANSI/ASME B36.19M Schedule 40s	65
<b>Threaded connections</b>	
Threaded sockets DIN ISO 228	1
Threaded spigots DIN 11851	6
Cone spigot and union nut DIN 11851	6K
Aseptic unions on request	
<b>Flanges</b>	
Flanges EN 1092 / PN16 / form B, length EN 558, series 1, ISO 5752, basic series 1	8*
Flanges ANSI Class 150 RF, length MSS SP-88	38*
Flanges ANSI Class 125/150 RF, length EN 558, series 1, ISO 5752, basic series 1	39*
<b>Clamp connections</b>	
Clamps ASME BPE for pipe ASME BPE, length ASME BPE	80
Clamps DIN 32676 series B for pipe EN ISO 1127, length EN 558, series 7	82
Clamps ASME BPE for pipe ASME BPE, length EN 558, series 7	88
Clamps DIN 32676 series A for pipe DIN 11850, length EN 558, series 7	8A
Clamps SMS 3017 for pipe SMS 3008, length EN 558, series 7	8E
Clamps DIN 32676 series C, length FTF ASME BPE	8P
Clamps DIN 32676 series C, length FTF EN 558 series 7	8T
Aseptic clamps on request	

\* Connection code 8, 38, 39 only possible in conjunction with actuator version code B / R

For overview of available valve bodies see page 15/16

Valve body material	Code
1.4435, investment casting	C3
1.4408, investment casting	37
1.4408, PFA lined	39
1.4435 (316L), forged body	40
1.4435 (316L), block material	41
1.4435 (BN2), forged body $\Delta$ Fe<0.5%	42
1.4435 (BN2), block material, $\Delta$ Fe<0,5 %	43
1.4539, forged body	F4

Diaphragm material	Code
EPDM	13 3A*
EPDM	17
EPDM	19
PTFE/EPDM, one-piece	54
PTFE/EPDM, two-piece	5M**
PTFE/EPDM, two-piece	5Q
PTFE/PVDF/EPDM, three-piece	71***
* for diaphragm size 8	
** Code 5M available from diaphragm size 10	
*** Code 71 only available for bodies with PFA lining (Code 39)	
Material complies with FDA requirements	

Control function	Code
Normally closed (NC)	1
Normally open (NO)	2
Double acting (DA) (with opening spring)	3

Actuator size	Code
Actuator size 0 (diaphragm size 8)	0
Actuator size 1 (diaphragm size 10)	1
Actuator size 2 (diaphragm size 25)	2
Actuator size 3 (diaphragm size 40)	3
Actuator size 4 (diaphragm size 50)	4
Actuator size 5 (diaphragm size 80)	5
Actuator size 6 (diaphragm size 100)	6
Actuator size 8 (diaphragm size 150)	8

Actuator version	Code
Only for body configuration D (diaphragm size 10 - 50)	D
For body config. D (diaphragm size 10 - 50) Control air connector 90° offset to flow direction	B
For body config. B, D, M and T (diaphragm size 8 - 100)	T
For body config. B, D, M and T (diaphragm size 8 - 100) Control air connector 90° offset to flow direction	R

Spring set	Code
Standard	1
For higher operating pressure	A
For higher operating pressure	B

## Order data (2/2-way valves)

### Internal surface finishes for forged and block material bodies <sup>1)</sup>

Readings for Process Contact Surfaces	Mechanically polished <sup>2)</sup>		Electropolished	
	Hygienic class DIN 11866	Code	Hygienic class DIN 11866	Code
Ra ≤ 0.80 µm	H3	1502	HE3	1503
Ra ≤ 0.60 µm	-	1507	-	1508
Ra ≤ 0.40 µm	H4	1536	HE4	1537
Ra ≤ 0.25 µm <sup>3)</sup>	H5	1527	HE5	1516

Readings for Process Contact Surfaces acc. to ASME BPE 2016 <sup>4)</sup>	Mechanically polished <sup>2)</sup>		Electropolished	
	ASME BPE Surface Designation	Code	ASME BPE Surface Designation	Code
Ra Max. = 0.76 µm (30 µinch)	SF3	SF3	-	-
Ra Max. = 0.64 µm (25 µinch)	SF2	SF2	SF6	SF6
Ra Max. = 0.51 µm (20 µinch)	SF1	SF1	SF5	SF5
Ra Max. = 0.38 µm (15 µinch)	-	-	SF4	SF4

### Internal surface finishes for investment cast bodies

Readings for Process Contact Surfaces	Mechanically polished <sup>2)</sup>	
	Hygienic class DIN 11866	Code
Ra ≤ 6.30 µm	-	1500
Ra ≤ 0.80 µm	H3	1502
Ra ≤ 0.60 µm <sup>5)</sup>	-	1507

<sup>1)</sup> Surface finishes of customized valve bodies may be limited in special cases.

<sup>2)</sup> Or any other finishing method that meets the Ra value (acc. to ASME BPE).

<sup>3)</sup> The smallest possible Ra finish for pipe connections with an internal pipe diameter < 6 mm is 0.38 µm.

<sup>4)</sup> When using these surfaces, the bodies are marked according to the specifications of ASME BPE.

The surfaces are only available for valve bodies which are made of materials (e.g. GEMÜ material codes 40, 41, F4, 44) and use connections (e.g. GEMÜ connection codes 59, 80, 88) according to ASME BPE.

<sup>5)</sup> Not possible for GEMÜ connection code 59, DN 8 and GEMÜ connection code 0, DN 4.

Ra acc. to DIN EN ISO 4288 and ASME B46.1

### Special function

Code

3-A compliant design

M

Order example	650	50	D	60	40	54	1	4	T	1	1503	M
Type	650											
Nominal size		50										
Body configuration (code)			D									
Connection (code)				60								
Valve body material (code)					40							
Diaphragm material (code)						54						
Control function (code)							1					
Actuator size (code)								4				
Actuator version (code)									T			
Spring set (code)										1		
Surface finish (code)											1503	
Special function (Code)												M



## Dimensions [mm]

### Actuator dimensions

Actuator size	Diaphragm size	A	A1	A2	ø B	G	M	Weight [kg]	
								Version D	Version T
0T1	8	80.5	28	37.8	42	G 1/8	M12x1	-	0.5
0TA	8	89.5	28	39.1	47	G 1/8	M12x1	-	0.5
1T1	10	116.0	37	42.5	61	G 1/4	M16x1	1.1	0.9
2T1	25	137.5	38	53.0	90	G 1/4	M16x1	2.5	1.9
3T1	40	173.0	53	56.5	114	G 1/4	M16x1	5.0	3.0
3TA	40	223.0	52	-	144	G 1/4	M16x1	-	7.3
4T1	50	223.0	52	70.5	144	G 1/4	M16x1	9.5	7.7
5T1	80	283.0	78	-	240	G 1/4	M26x1.5	-	18.5
5TA/5TB	80	297.0	80	-	240	G 1/4	M26x1.5	-	23.7
6T1	100	298.0	87	-	240	G 1/4	M26x1.5	-	20.0
6TA	100	355.0	133	-	240	G 1/4	M26x1.5	-	28.0
8TA	150	513.0	166	-	308	G 1/4	M26x1.5	-	95.0

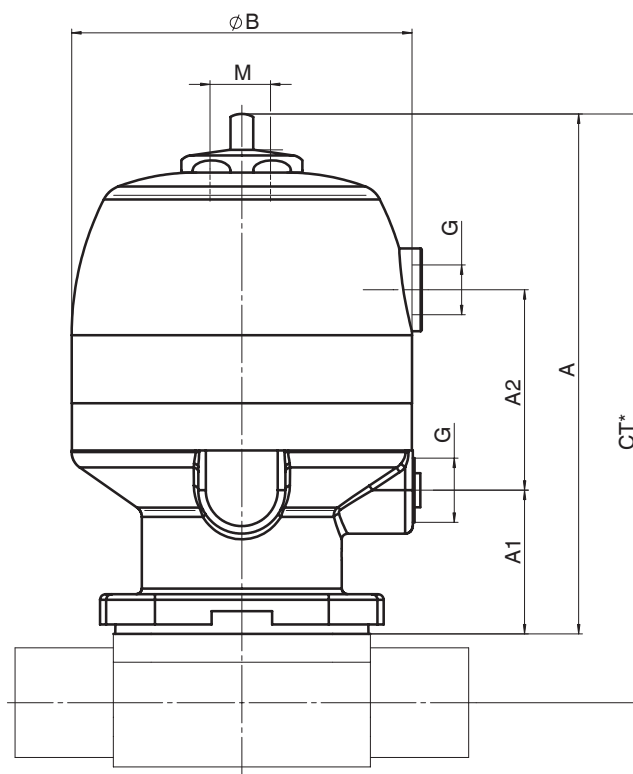

\* CT = A + H1 (see body dimensions)

## Body dimensions [mm]

**Butt weld spigots, connection code 0, 16, 17, 18**  
**Valve body material: Investment casting (code C3), forged body (code 40, F4)**

Pipe standard							DIN		EN 10357 series B (formerly DIN 11850 series 1)		EN 10357 series A (formerly DIN 11850 series 2) / DIN 11866 series A		DIN 11850 Series 3		Weight [kg]
Connection code							0		16		17		18		
MG	DN	NPS	L	C (min)	H1*	H1**	ød	s	ød	s	ød	s	ød	s	
8	4	-	72	20	8.5		6	1.0	-	-	-	-	-	-	0.09
	6	-	72	20	8.5		-	-	-	-	8	1.0	-	-	0.09
	8	1/4"	72	20	8.5		-	-	-	-	10	1.0	-	-	0.09
	10	3/8"	72	20	8.5		-	-	12	1.0	13	1.5	14	2.0	0.09
10	10	3/8"	108	25	12.5		-	-	12	1.0	13	1.5	14	2.0	0.30
	15	1/2"	108	25	12.5		18	1.5	18	1.0	19	1.5	20	2.0	0.30
25	15	1/2"	120	25	13.0	19.0	18	1.5	18	1.0	19	1.5	20	2.0	0.62
	20	3/4"	120	25	16.0	19.0	22	1.5	22	1.0	23	1.5	24	2.0	0.58
	25	1"	120	25	19.0	19.0	28	1.5	28	1.0	29	1.5	30	2.0	0.55
40	32	1 1/4"	153	25	24.0	26.0	34	1.5	34	1.0	35	1.5	36	2.0	1.45
	40	1 1/2"	153	30.5	26.0	26.0	40	1.5	40	1.0	41	1.5	42	2.0	1.32
50	50	2"	173	30	32.0	32.0	52	1.5	52	1.0	53	1.5	54	2.0	2.25
80	65	2 1/2"	216	30	-	62.0	-	-	-	-	70	2.0	-	-	8.60
	80	3"	254	30	-	62.0	-	-	-	-	85	2.0	-	-	8.00
100	100	4"	305	30	-	76.0	-	-	-	-	104	2.0	-	-	24.10

\* only for investment cast design      \*\* only for forged design      MG = diaphragm size  
 For materials see overview on page 18

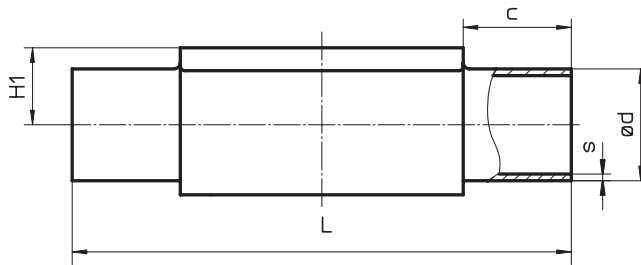

## Body dimensions [mm]

### Butt weld spigots, connection code 60 Valve body material: Investment casting (code C3), forged body (code 40, F4)

Pipe standard							ISO 1127 / EN 10357 series C / DIN 11866 series B		Weight [kg]
Connection code							60		
MG	DN	NPS	L	c (min)	H1*	H1**	ød	s	
8	6	-	72	20	-	8.5	10.2	1.6	0.09
	8	1/4"	72	20	8.5	8.5	13.5	1.6	0.09
	10	3/8"	72	20	-	8.5	-	-	0.09
10	10	3/8"	108	25	12.5	12.5	17.2	1.6	0.30
	15	1/2"	108	25	12.5	12.5	21.3	1.6	0.30
25	15	1/2"	120	25	13.0	19.0	21.3	1.6	0.62
	20	3/4"	120	25	16.0	19.0	26.9	1.6	0.58
	25	1"	120	25	19.0	19.0	33.7	2.0	0.55
40	32	1 1/4"	153	25	24.0	26.0	42.4	2.0	1.45
	40	1 1/2"	153	30.5	26.0	26.0	48.3	2.0	1.32
50	50	2"	173	30	32.0	32.0	60.3	2.0	2.25
80	65	2 1/2"	216	30	-	62.0	76.1	2.0	8.60
	80	3"	254	30	-	62.0	88.9	2.3	8.00
100	100	4"	305	30	-	76.0	114.3	2.3	24.10

\* only for investment cast design

\*\* only for forged design

MG = diaphragm size

For materials see overview on page 18.

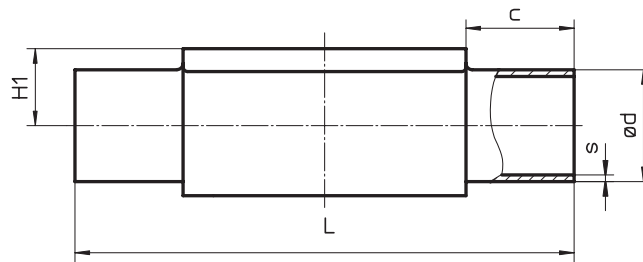

## Body dimensions [mm]

**Butt weld spigots, connection code 35, 36, 37**  
**Valve body material: Investment casting (code C3), forged body (code 40, F4)**

Pipe standard							JIS-G 3447	JIS-G 3459	SMS 3008	Weight [kg]			
Connection code							35	36	37				
MG	DN	NPS	L	c (min)	H1*	H1**	ød	s	ød			s	ød
8	6	-	72	20	-	8.5	-	-	10.5	1.20	-	-	0.09
	8	1/4"	72	20	-	8.5	-	-	13.8	1.65	-	-	0.09
10	10	3/8"	108	25	-	12.5	-	-	17.3	1.65	-	-	0.30
	15	1/2"	108	25	-	12.5	-	-	21.7	2.10	-	-	0.30
25	15	1/2"	120	25	-	19.0	-	-	21.7	2.10	-	-	0.62
	20	3/4"	120	25	-	19.0	-	-	27.2	2.10	-	-	0.58
	25	1"	120	25	19.0	19.0	25.4	1.2	34.0	2.80	25.0	1.2	0.55
40	32	1 1/4"	153	25	-	26.0	31.8	1.2	42.7	2.80	33.7	1.2	1.45
	40	1 1/2"	153	30.5	26.0	26.0	38.1	1.2	48.6	2.80	38.0	1.2	1.32
50	50	2"	173	30	32.0	32.0	50.8	1.5	60.5	2.80	51.0	1.2	2.25
	65	2 1/2"	173	30	-	34.0	63.5	2.0	-	-	63.5	1.6	2.20
80	65	2 1/2"	216	30	-	62.0	63.5	2.0	76.3	3.00	63.5	1.6	8.60
	80	3"	254	30	-	62.0	76.3	2.0	89.1	3.00	76.1	1.6	8.00
100	100	4"	305	30	-	76.0	101.6	2.0	114.3	3.00	101.6	2.0	24.10

\* only for investment cast design

\*\* only for forged design

MG = diaphragm size

For materials see overview on page 18

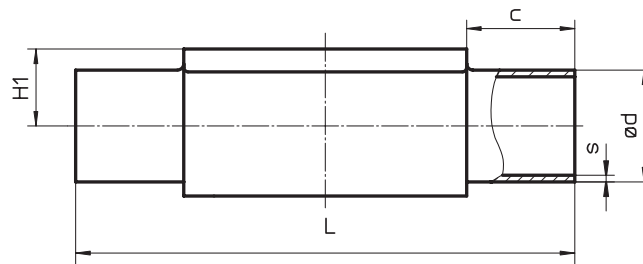

## Body dimensions [mm]

**Butt weld spigots, connection code 55, 59, 63, 64, 65**  
**Valve body material: Investment casting (code C3), forged body (code 40, F4),**  
**block material (code 41)**

Pipe standard							BS 4825 Part 1	ASME BPE / DIN 11866 series C	ANSI/ASME B36.19M Schedule 10s	ANSI/ASME B36.19M Schedule 5s	ANSI/ASME B36.19M Schedule 40s	Weight [kg]					
Connection code							55	59	63	64	65						
MG	DN	NPS	L	c (min)	H1*	H1**	ød	s	ød	s	ød		s	ød	s	ød	s
8	6	-	72	20	-	8.5	-	-	-	-	10.3	1.24	-	-	10.3	1.73	0.09
	8	1/4"	72	20	8.5	8.5	6.35	1.2	6.35	0.89	13.7	1.65	-	-	13.7	2.24	0.09
	10	3/8"	72	20	8.5	8.5	9.53	1.2	9.53	0.89	-	-	-	-	-	-	0.09
	15	1/2"	72	20	8.5	8.5	12.70	1.2	12.70	1.65	-	-	-	-	-	-	0.09
10	10	3/8"	108	25	-	12.5	9.53	1.2	9.53	0.89	17.1	1.65	-	-	17.1	2.31	0.30
	15	1/2"	108	25	-	12.5	12.70	1.2	12.70	1.65	21.3	2.11	21.3	1.65	21.3	2.77	0.30
	20	3/4"	108	25	12.5	12.5	19.05	1.2	19.05	1.65	-	-	-	-	-	-	0.30
25	15	1/2"	120	25	-	19.0	-	-	-	-	21.3	2.11	21.3	1.65	21.3	2.77	0.62
	20	3/4"	120	25	16.0	19.0	19.05	1.2	19.05	1.65	26.7	2.11	26.7	1.65	26.7	2.87	0.58
	25	1"	120	25	19.0	19.0	-	-	25.40	1.65	33.4	2.77	33.4	1.65	33.4	3.38	0.55
40	32	1 1/4"	153	25	-	26.0	-	-	-	-	42.2	2.77	42.2	1.65	42.2	3.56	1.45
	40	1 1/2"	153	30.5	26.0	26.0	-	-	38.10	1.65	48.3	2.77	48.3	1.65	48.3	3.68	1.32
50	50	2"	173	30	32.0	32.0	-	-	50.80	1.65	60.3	2.77	60.3	1.65	60.3	3.91	2.25
	65	2 1/2"	173	30	-	34.0	-	-	63.50	1.65	-	-	-	-	-	-	2.10
80	65	2 1/2"	216	30	-	62.0	-	-	63.50	1.65	73.0	3.05	73.0	2.11	73.0	5.16	8.60
	80	3"	254	30	-	62.0	-	-	76.20	1.65	88.9	3.05	88.9	2.11	88.9	5.49	8.00
100	100	4"	305	30	-	76.0	-	-	101.60	2.11	114.3	3.05	114.3	2.11	114.3	6.02	24.10
150	150	6"	406	48	-	101.0	-	-	152.40	2.77	-	-	168.3	2.77	-	-	42.00

\* only for investment cast design

\*\* only for forged design

MG = diaphragm size

For materials see overview on page 18

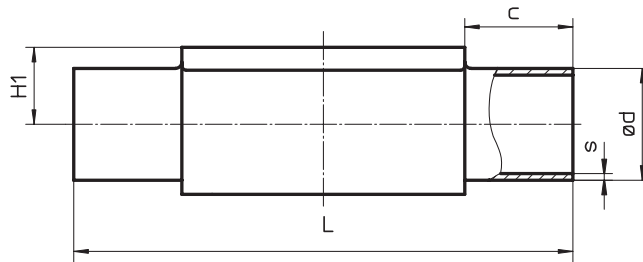

## Body dimensions [mm]

### Threaded sockets, connection code 1 Valve body material: Investment casting (code 37)

MG	DN	R	H	H1	t	L	SW2	Number of flats	Weight [kg]
8	8	G 1/4	19.0	9.0	11	72	18	6	0.09
10	12	G 3/8	25.0	13.0	12	55	22	2	0.17
	15	G 1/2	30.0	15.0	15	68	27	2	0.26
25	15	G 1/2	28.3	14.8	15	85	27	6	0.32
	20	G 3/4	33.3	17.3	16	85	32	6	0.34
	25	G 1	42.3	21.8	13	110	41	6	0.39
40	32	G 1 1/4	51.3	26.3	20	120	50	8	0.88
	40	G 1 1/2	56.3	28.8	18	140	55	8	0.93
50	50	G 2	71.3	36.3	26	165	70	8	1.56

MG = diaphragm size

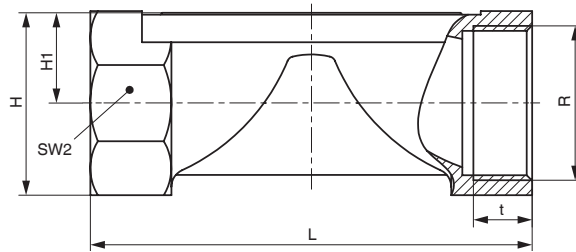

### Threaded connections, connection code 6 Valve body material: Forged body (code 40)

MG	DN	H1	ød1	Thread to DIN 405 R	L	Weight [kg]
8	10	8.5	10.0	RD 28 x 1/8	92	0.21
10	10	12.5	10.0	RD 28 x 1/8	118	0.33
	15	12.5	16.0	RD 34 x 1/8	118	0.35
25	15	19.0	16.0	RD 34 x 1/8	118	0.71
	20	19.0	20.0	RD 44 x 1/6	118	0.78
	25	19.0	26.0	RD 52 x 1/6	128	0.79
40	32	26.0	32.0	RD 58 x 1/6	147	1.66
	40	26.0	38.0	RD 65 x 1/6	160	1.62
50	50	32.0	50.0	RD 78 x 1/6	191	2.70
80	65	62.0	66.0	RD 95 x 1/6	246	9.22
	80	62.0	81.0	RD 110 x 1/4	256	9.20

MG = diaphragm size

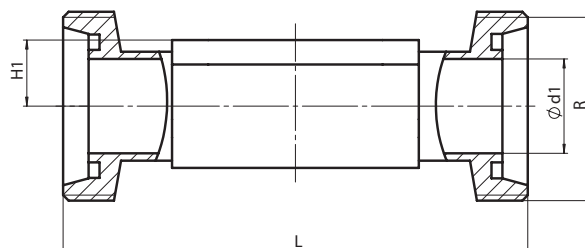

**Body dimensions [mm]**

**Cone spigot, connection code 6K  
Valve body material: Forged body (code 40)**

MG	DN	H1	ød1	Thread to DIN 405 R	L	Weight [kg]
8	10	8.5	10.0	RD 28 x 1/8	90	0.21
10	10	12.5	10.0	RD 28 x 1/8	116	0.33
	15	12.5	16.0	RD 34 x 1/8	116	0.35
25	15	19.0	16.0	RD 34 x 1/8	116	0.71
	20	19.0	20.0	RD 44 x 1/6	114	0.78
	25	19.0	26.0	RD 52 x 1/6	127	0.79
40	32	26.0	32.0	RD 58 x 1/6	147	1.66
	40	26.0	38.0	RD 65 x 1/6	160	1.62
50	50	32.0	50.0	RD 78 x 1/6	191	2.70
80	65	62.0	66.0	RD 95 x 1/6	246	9.22
	80	62.0	81.0	RD 110 x 1/4	256	9.20

MG = diaphragm size

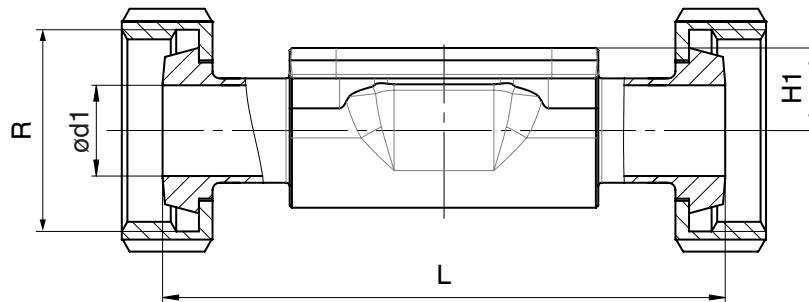

## Body dimensions [mm]

### Flanges - DIN EN 1092, connection code 8 Valve body material investment casting (code C3), forged body (code 40), investment casting PFA lined (code 39)

MG	DN	øD	øk	øL	Number of bolts	H1			FTF	Weight [kg]
						Material code C3	Material code 39	Material code 40		
25	15	95	65	14	4	13.0	18.0	19.0	130*	1.85
	20	105	75	14	4	16.0	20.5	19.0	150	2.35
	25	115	85	14	4	19.0	23.0	19.0	160	2.85
40	32	140	100	19	4	24.0	28.7	26.0	180	4.90
	40	150	110	19	4	26.0	33.0	26.0	200	5.65
50	50	165	125	19	4	32.0	39.0	32.0	230	7.45
80	65	185	145	19	4	-	51.0	62.0	290	10.20
	80	200	160	19	8	-	59.5	62.0	310	14.20
100	100	220	180	19	8	-	73.0	76.0	350	21.00

\* Material code C3, 40 FTF = 150 (no DIN length)

MG = diaphragm size

For materials see overview on page 19

### Flanges - ANSI Class 125/150 RF, connection code 38, 39 Valve body material investment casting (code C3), forged body (code 40), investment casting PFA lined (code 39)

MG	DN	øD	øk	øL	Number of bolts	H1			FTF		Weight [kg]
						Material code C3	Material code 39	Material code 40	Connection code 38	Connection code 39	
25	15	90	60.3	15.9	4	13.0	18.0	19.0	-	130*	1.85
	20	100	69.9	15.9	4	16.0	20.5	19.0	146	150	2.35
	25	110	79.4	15.9	4	19.0	23.0	19.0	146	160	2.85
40	32	115	88.9	15.9	4	24.0	28.7	26.0	-	180	4.90
	40	125	98.4	15.9	4	26.0	33.0	26.0	175	200	5.65
50	50	150	120.7	19.0	4	32.0	39.0	32.0	200	230	7.45
80	65	180	139.7	19.0	4	-	51.0	62.0	226	290	10.20
	80	190	152.4	19.0	4	-	59.5	62.0	260	310	14.20
100	100	230	190.5	19.0	8	-	73.0	76.0	327	350	21.00

\* Material code C3, 40 FTF = 150 (no DIN length)

MG = diaphragm size

For materials see overview on page 19

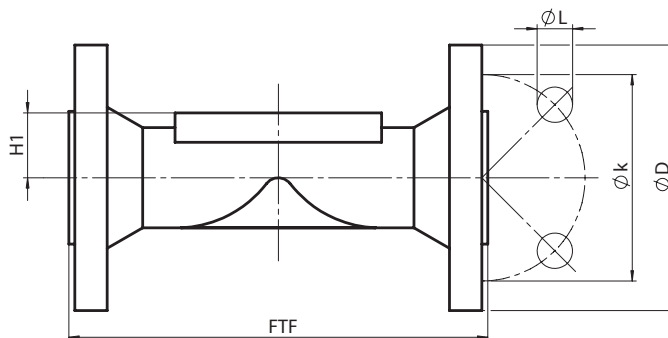



## Body dimensions [mm]

**Clamp connections, connection code 80, 82, 88, 8A, 8E, 8P, 8T**  
**Valve body material: Forged body (code 40, F4),**  
**block material (code 41)**

Pipe connection for clamp			ASME BPE							ISO 1127 / EN 10357 series C / DIN 11866 series B			EN 10357 series A (formerly DIN 11850 series 2) / DIN 11866 series A			SMS 3008			Weight [kg]
Clamp connection			Code 80, 88 - ASME BPE Code 8P, 8T - DIN 32676 series C							DIN 32676 series B			DIN 32676 series A			ISO 2852 / SMS 3017			
Clamp connection code			80, 8P			88, 8T				82			8A			8E			
MG	DN	NPS	H1	ød1	ød3	L	ød1	ød3	L	ød1	ød3	L	ød1	ød3	L	ød1	ød3	L	
8	6	1/8"	8.5	-	-	-	-	-	-	7.0	25.0	63.5	6	25.0	63.5	-	-	-	-
	8	1/4"	8.5	4.57	25.0	63.5	-	-	-	10.3	25.0	63.5	8	25.0	63.5	-	-	-	0.15
	10	3/8"	8.5	7.75	25.0	63.5	-	-	-	-	-	-	10	34.0	88.9	-	-	-	0.18
	15	1/2"	8.5	9.40	25.0	63.5	9.40	25.0	108	-	-	-	-	-	-	-	-	-	0.18
10	10	3/8"	12.5	-	-	-	-	-	-	14.0	25.0	108.0	10	34.0	108.0	-	-	-	0.30
	15	1/2"	12.5	9.40	25.0	88.9	9.40	25.0	108	18.1	50.5	108.0	16	34.0	108.0	-	-	-	0.43
	20	3/4"	12.5	15.75	25.0	101.6	15.75	25.0	117	-	-	-	-	-	-	-	-	-	0.43
25	15	1/2"	19.0	-	-	-	-	-	-	18.1	50.5	108.0	16	34.0	108.0	-	-	-	0.75
	20	3/4"	19.0	15.75	25.0	101.6	15.75	25.0	117	23.7	50.5	117.0	20	34.0	117.0	-	-	-	0.71
	25	1"	19.0	22.10	50.5	114.3	22.10	50.5	127	29.7	50.5	127.0	26	50.5	127.0	22.6	50.5	127	0.63
40	32	1 1/4"	26.0	-	-	-	-	-	-	38.4	64.0	146.0	32	50.5	146.0	31.3	50.5	146	1.62
	40	1 1/2"	26.0	34.80	50.5	139.7	34.80	50.5	159	44.3	64.0	159.0	38	50.5	159.0	35.6	50.5	159	1.50
50	50	2"	32.0	47.50	64.0	158.8	47.50	64.0	190	56.3	77.5	190.0	50	64.0	190.0	48.6	64.0	190	2.50
	65	2 1/2"	34.0	60.20	77.5	193.8	60.20	77.5	216	-	-	-	-	-	-	60.3	77.5	216	2.30
80	65	2 1/2"	62.0	60.20	77.5	193.8	60.20	77.5	216	72.1	91.0	216.0	66	91.0	216.0	60.3	77.5	216	8.90
	80	3"	62.0	72.90	91.0	222.3	72.90	91.0	254	84.3	106.0	254.0	81	106.0	254.0	72.9	91.0	254	8.50
100	100	4"	76.0	97.38	119.0	292.1	97.38	119.0	305	109.7	130.0	305.0	100	119.0	305.0	97.6	119.0	305	24.80
150	150	6"	101.0	-	-	-	146.86	167.0	406	-	-	-	-	-	-	-	-	-	43.10

MG = diaphragm size

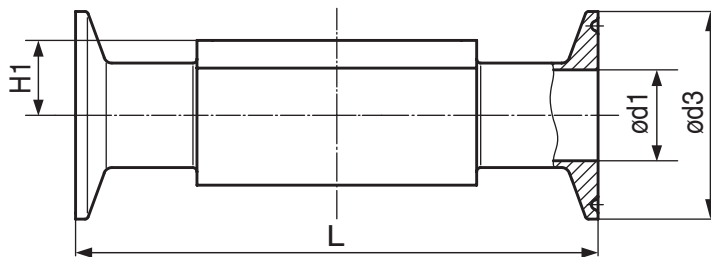

## Overview of valve bodies for GEMÜ 650

		Spigots																		
Connection code		0		16	17		18	35	36	37		55	59			60		63	64	65
Material code		C3	40	40	C3	40	40	40	40	C3	40	40	C3	40	41	C3	40	40	40	40
MG	DN																			
8	4	X	X	-	-	-	-	-	-	-	-	-	-	-	-	-	-	-	-	-
	6	-	-	-	X	X	-	-	X	-	-	-	-	-	-	-	X	X	-	X
	8	-	-	-	X	X	-	-	X	-	-	X	X	X	-	X	X	X	-	X
	10	-	-	X	X	X	X	-	-	-	-	X	X	X	-	-	-	-	-	-
	15	-	-	-	-	-	-	-	-	-	-	X	X	X	-	-	-	-	-	-
10	10	-	-	X	X	X	X	-	X	-	-	X	-	X	-	X	X	X	-	X
	15	-	X	X	X	X	X	-	X	-	-	X	-	X	-	X	X	X	X	X
	20	-	-	-	-	-	-	-	-	-	-	X	X	X	-	-	-	-	-	-
25	15	-	X	X	X	X	X	-	X	-	-	-	-	-	-	X	X	X	X	X
	20	-	X	X	X	X	X	-	X	-	-	X	X	X	-	X	X	X	X	X
	25	-	X	X	X	X	X	X	X	X	X	-	X	X	-	X	X	X	X	X
40	32	-	X	X	X	X	X	X	X	-	X	-	-	-	-	X	X	X	X	X
	40	-	X	X	X	X	X	X	X	X	X	-	X	X	-	X	X	X	X	X
50	50	-	X	X	X	X	X	X	X	X	X	-	X	X	-	X	X	X	X	X
	65	-	-	-	-	-	-	X	-	-	X	-	-	X	-	-	-	-	-	-
80	65	-	-	-	-	X	-	X	X	-	X	-	-	X	-	-	X	X	X	X
	80	-	-	-	-	X	-	X	X	-	X	-	-	X	-	-	X	X	X	X
100	100	-	-	-	-	X	-	X	X	-	X	-	-	X	-	-	X	X	X	X
150	150	-	-	-	-	-	-	-	-	-	-	-	-	-	X	-	-	-	X	-

Availability of material code 42, F4: same as code 40  
 MG = diaphragm size

## Overview of valve bodies for GEMÜ 650

		Threaded connections			Clamps						Flanges						
Connection code		1	6	6K	80, 8P	82	88, 8T		8A	8E	8			38	39		
Material code		37	40	40	40	40	40	41	40	40	C3	39	40	39	C3	39	40
MG	DN																
8	6	-	-	-	-	K	-	-	K	-	-	-	-	-	-	-	-
	8	X	-	-	K	K	-	-	K	-	-	-	-	-	-	-	-
	10	-	W	W	K	-	-	-	W	-	-	-	-	-	-	-	-
	15	-	-	-	K	-	W	-	-	-	-	-	-	-	-	-	-
10	10	-	W	W	-	K	-	-	K	-	-	-	-	-	-	-	-
	12	X	-	-	-	-	-	-	-	-	-	-	-	-	-	-	-
	15	X	W	W	K	W	K	-	K	-	-	-	-	-	-	-	-
	20	-	-	-	K	-	K	-	-	-	-	-	-	-	-	-	-
25	15	X	W	W	-	W	-	-	K	-	W	X	W	-	W	X	W
	20	X	W	W	K	K	K	-	K	-	W	X	W	X	W	X	W
	25	X	W	W	K	K	K	-	K	K	W	X	W	X	W	X	W
40	32	X	W	W	-	W	-	-	K	K	W	X	W	-	W	X	W
	40	X	W	W	K	W	K	-	K	K	W	X	W	X	W	X	W
50	50	X	W	W	K	W	K	-	K	K	W	X	W	X	W	X	W
	65	-	-	-	W	-	W	-	-	W	-	-	-	-	-	-	-
80	65	-	W	W	K	K	K	-	K	K	-	-	W	-	-	-	W
	80	-	W	W	K	W	K	-	W	K	-	X	W	X	-	X	W
100	100	-	-	-	W	W	W	-	W	W	-	X	W	X	-	X	W
150	150	-	-	-	-	-	-	W	-	-	-	-	-	-	-	-	-

X = Standard  
 K = Connections completely machined (not welded)  
 W = Welded construction  
 Availability of material code 42, F4: same as code 40  
 MG = diaphragm size

For further metal diaphragm valves, accessories and other products, please see our Product Range catalogue and Price List.  
Contact GEMÜ.