

Product Information

VM-008..080GR

Flow Switch
VM-...GR



- **Highly reproducible**
- **Precise, stepless adjustment of the switching value**
- **High switching power**
- **Insensitive to dirt**
- **Short installation length**

Characteristics

The volume flow raises a disc unit with magnet against a spring force. A magnetic coupling actuates a hermetically separated micro switch.

Technical data

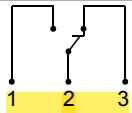
Switch	micro switch	
Nominal width	DN 8..80	
Process connection	female thread G 1/4..G 3	
Switching range	1..600 l/min	for details see table "Ranges"
Q_{max.}	to 720 l/min	
Tolerance	±5 % of full scale value	
Pressure resistance	G 1/4..G 1/2 - PN 100 bar	
	G 3/4..G 1 - PN 25 bar	
	G 1 1/4..G 3 - PN 16 bar	
Medium temperature	-20..+90 °C	
Ambient temperature	-20..+70 °C	
Media	water (oils and gases available on request)	
Wiring	changeover no. 0.213	
Switching voltage	max. 250 V AC	
Switching current	max. 6 A	
Protection class	2 - safety insulation	
Ingress protection	IP 65 (optional IP 44)	
Connection	plug DIN 43650-A / ISO 4400	
Materials medium-contact	Rg 5 / Rg 6 nickelled, POM, 1.4310, CW614N, NBR, hard ferrite	
Non-medium-contact materials	ABS, PA	
Weight	see table "Dimensions and weights"	

Installation location	Standard: horizontal inwards flow; switching head not recommended underneath; other installation positions are possible; the installation position affects the switching point and range.
------------------------------	---

Ranges

Details in the table correspond to horizontal inwards flow with decreasing flow rate.

G	Nominal width	Switching range l/min H ₂ O	Q _{max.} recommended	Types
G 1/4	DN 8	1 - 5	8	VM-008GR005
		3 - 12	15	VM-008GR012
G 3/8	DN 10	2 - 6	10	VM-010GR006
		3 - 12	15	VM-010GR012
G 1/2	DN 15	2 - 6		VM-015GR006
		4 - 20	30	VM-015GR020
G 3/4	DN 20	4 - 12	20	VM-020GR012
		10 - 40	50	VM-020GR040
G 1	DN 25	10 - 60	70	VM-025GR060
G 1 1/4	DN 32	20 - 100	120	VM-032GR100
G 1 1/2	DN 40	30 - 150	180	VM-040GR150
G 2	DN 50	50 - 250	300	VM-050GR250
G 2 1/2	DN 65	50 - 400	480	VM-065GR400
G 3	DN 80	100 - 600	720	VM-080GR600

Special ranges are available

Dimensions and weights

G	Types	H	L	SW	X	Weight kg
G 1/4	VM-008GR	144	68	29	12	1.2
G 3/8	VM-010GR					1.3
G 1/2	VM-015GR				13	1.4
G 3/4	VM-020GR		73	32	11	1.5
G 1	VM-025GR		87	41	12	1.7
G 1 1/4	VM-032GR	155	98	52	13	2.3
G 1 1/2	VM-040GR	156	113	59	14	3.0
G 2	VM-050GR	164	137	72	17	4.3
G 2 1/2	VM-065GR	195	160	85	26	5.8
G 3	VM-080GR		148	100	23	7.0

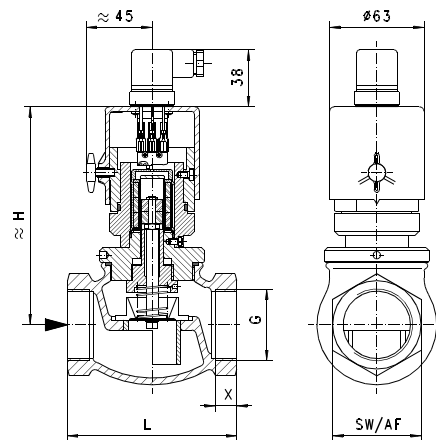

Product Information

VM-008..080GR

Handling and operation

Note

- Include straight calming section of 5 x DN in inlet and outlet
- Include a filter if the media are dirty (use magnetic filter for ferritic components).
- It must be ensured that the values given for voltage, current, and power are not exceeded.
- When switched on, a load must be connected in series.
- The electrical details apply to ohmic loads. Capacitive and inductive loads must be operated using a protective circuit.

Adjustment

To adjust the switching point, the fixing screw for the switching head must be loosened. The switching head can then be rotated. Turning to the right increases the switching point, and vice-versa. Then retighten the fixing screw.



Ordering code

VM -
VM -

1. Nominal width	
008	DN 8 - G 1/4
010	DN 10 - G 3/8
015	DN 15 - G 1/2
020	DN 20 - G 3/4
025	DN 25 - G 1
032	DN 32 - G 1 1/4
040	DN 40 - G 1 1/2
050	DN 50 - G 2
065	DN 65 - G 2 1/2
080	DN 80 - G 3
2. Process connection	
G	female thread
3. Connection material	
R	red bronze
4. Switching range H₂O for horizontal inwards flow	
005	1 - 5 l/min
006	2 - 6 l/min
012	3 - 12 l/min
	4 - 12 l/min
020	3 - 20 l/min
	4 - 20 l/min
040	10 - 40 l/min
060	10 - 60 l/min
100	20 - 100 l/min
150	30 - 150 l/min
250	50 - 250 l/min
400	50 - 400 l/min
600	100 - 600 l/min
5. Optional for ATEX	
A	for switching head ATEX A-V2 or A-V3 (The switching head is ordered in addition) 

Options

- Special plugs, Tuchel / Harting
- Signal lamp red or red / green in the plug DIN 43650-A
- Other signal lamp
- Temperature display 0..120 °C
- Temperature monitoring 40..90 °C
- Temperature resistant up to 150 °C
- Metal cap
- Gold contact microswitch 125 V AC / 30 V DC, 100 mA
- Germanischer Lloyd
- Switching ranges for oil or gas
- Special values

Ordering information

- Specify direction of flow, medium, and switching range.
- For oils. State viscosity, temperature and designation (e.g. ISO VG 68) (enquire about switching range).
- For gases, state pressure (relative or absolute), temperature and medium (e.g. air) (request switching range).