

Technical Information

Condumax W **CLS15** and CLS15D

Conductivity sensors, analog or digital with Memosens technology,
Cell constant $k = 0.01 \text{ cm}^{-1}$ or $k = 0.1 \text{ cm}^{-1}$



Application

Measurement in pure and ultrapure water:

- Monitoring ion exchangers
- Reverse osmosis
- Distillation
- Chip cleaning

The measuring range of the sensors depends on the cell constant k :

- $k = 0.01 \text{ cm}^{-1}$: 0.04 to 20 $\mu\text{S}/\text{cm}$
- $k = 0.1 \text{ cm}^{-1}$: 0.1 to 200 $\mu\text{S}/\text{cm}$

Sensors with a temperature sensor are used together with conductivity transmitters equipped with automatic temperature compensation:

- Liquiline M CM42
- Mycom S CLM153
- Liquisys M CLM223/253

For measurement of resistivity, $\text{M}\Omega \cdot \text{cm}$ measuring ranges are available in the menus of these transmitters.

Your benefits

- High measuring accuracy as cell constant is individually measured
- Installation in pipes or flow chambers
- Compact design
- Available with plug-in head or fixed cable
- Easy to clean thanks to polished measuring surfaces
- Can be sterilized up to max. 140°C (284°F)
- Stainless steel 1.4435 (AISI 316L)
- Quality certificate stating the individual cell constant
- Available with inspection certificate according to EN 10204 3.1

Further benefits offered by Memosens technology

- Maximum process safety through contactless inductive signal transmission
- Data safety through digital data transmission
- Easy handling thanks to storage of sensor-specific data
- Predictive maintenance possible thanks to registration of sensor load data

Function and system design

Measuring principle

Conductive measurement of conductivity

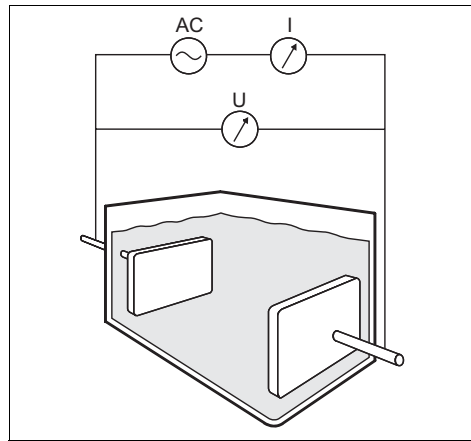

Conductive measurement of conductivity

AC Power supply
 I Current meter
 U Voltage meter

The conductivity of liquids is measured with the following measurement setup: Two electrodes are immersed in the medium. An AC voltage is applied to these electrodes which generates a current in the medium.

The electric resistance or its reciprocal value, the conductance G , is calculated according to Ohm's law. The specific conductivity κ is determined using the cell constant k that is dependent on the sensor geometry.

General properties

■ Electrodes

The sensor has two coaxially arranged measuring electrodes made of polished, stainless steel 1.4435 (AISI 316L).

■ Temperature measurement

In addition, a temperature sensor is installed in the inside electrode to measure the medium temperature.

■ Installation

The sensors are available with various process connections and can be installed directly.

For simple installation in cross or T-pieces with DN 32, 40 or 50, adapter couplings (made of PVC for cementing) are available.

■ Durable and sterilizable

- The sensors are pressure-proof up to 12 bar at 20°C (174 psi at 68°F).
- They are suitable for continuous operation up to 120°C at 1 bar (248°F at 14.5 psi).
- Short-time sterilization up to 140 °C at 1 bar (284 °F at 14.5 psi) is possible.
- For CLS15D, the maximum temperature for communication with the transmitter is 130°C (266°F).

Important properties CLS15D

Maximum process safety

The inductive and non-contacting measured value transmission of Memosens guarantees maximum process safety and offers the following benefits:

- All problems caused by moisture are eliminated.
 - The plug-in connection is free from corrosion.
 - Measured value distortion from moisture is not possible.
 - The plug-in system can even be connected under water.
- The transmitter is galvanically decoupled from the medium.
- EMC safety is guaranteed by screening measures for the digital measured value transmission.

Data safety through digital data transfer

The Memosens technology digitalizes the measured values in the sensor and transfers them to the transmitter contactlessly and free from interference potential. The result:

- An automatic error message is generated if the sensor fails or the connection between sensor and transmitter is interrupted.
- The availability of the measuring point is dramatically increased by immediate error detection.
- Application in hazardous areas is unproblematic; the integrated electronics are intrinsically safe.

Easy handling

Sensors with Memosens technology have integrated electronics that allow for saving calibration data and further information such as total hours of operation and operating hours under extreme measuring conditions. When the sensor is connected, the calibration data are automatically transferred to the transmitter and used to calculate the current measured value. Storing the calibration data in the sensor allows for calibration and adjustment away from the measuring point. The result:

- Sensors can be calibrated under optimum external conditions in the measuring lab. Wind and weather do neither affect the calibration quality nor the operator.
- The measuring point availability is dramatically increased by the quick and easy replacement of precalibrated sensors.
- Maintenance intervals can be defined based on all stored sensor load and calibration data and predictive maintenance is possible.
- The sensor history can be documented on external data carriers and evaluation programs at any time. Thus, the current application of the sensors can be made to depend on their previous history.

Communication with the transmitter

Always connect digital sensors to a transmitter with Memosens technology. Data transmission to a transmitter for analog sensors is not possible.

Data storage of CLS15D

Digital sensors are able to store the following system data in the sensor.

- Manufacturing data
 - Serial number
 - Order code
 - Date of manufacture
- Calibration data
 - Calibration date
 - Cell constant
 - Change in cell constant
 - Number of calibrations
 - Serial number of the transmitter used for the last calibration
- Application data
 - Temperature application range
 - Conductivity application range
 - Date of first commissioning
 - Maximum temperature value
 - Operating hours at temperatures above 80°C / 120°C (176°F / 248°F)
 - Number of sterilizations

Measuring system

- A complete measuring system comprises:
- a CLS15 or CLS15D conductivity sensor
 - a transmitter, e.g. Liquiline M CM42
 - a measuring cable, e.g. CYK71 or CYK10 Memosens data cable

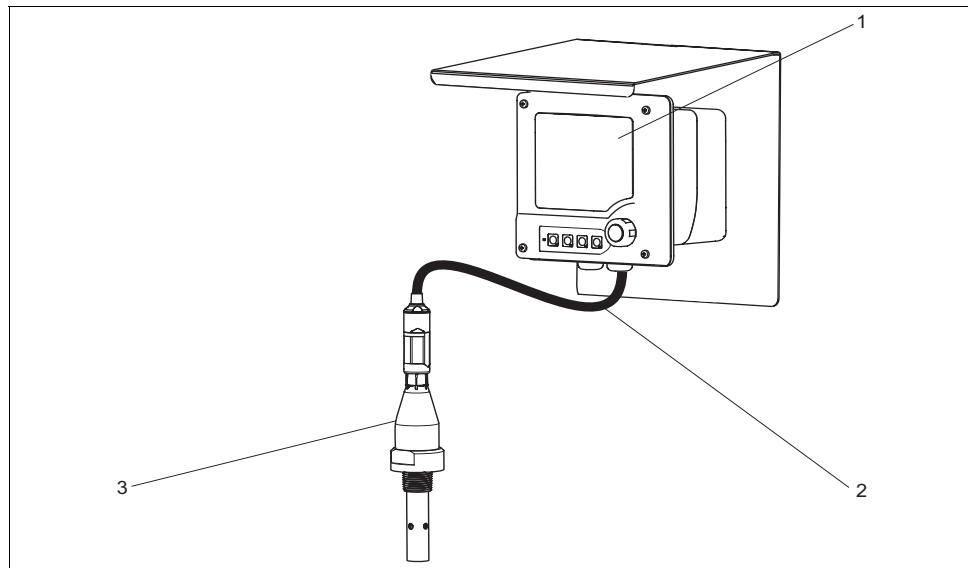

Measuring system example

- 1 Liquiline M CM42
- 2 CYK10 Memosens data cable
- 3 Condumax W CLS15D

Input

Measured values	Conductivity Temperature	
Cell constant k	Depending on ordered version: k = 0.01 cm ⁻¹ k = 0.1 cm ⁻¹	
Measuring ranges	Conductivity measurement	(referenced to water at 25°C / 77°F 0.04 µS/cm to 20 µS/cm 0.1 µS/cm to 200 µS/cm in the following temperature range CLS15: -20 to 140°C (-4 to 284°F) CLS15D: -20 to 100°C (-4 to 212°F) (spec. measuring accuracy up to 100°C / 212°F, communication up to 130 °C / 266 °F)
	Temperature measurement	CLS15: -20 to 140°C (-4 to 284°F) CLS15D: -20 to 100°C (-4 to 212°C) (spec. measuring accuracy up to 100°C / 212°F, communication up to 130°C / 266°F)
Temperature sensor	CLS15:	Pt 100 Class A according to DIN IEC 751
	CLS15D:	NTC

Cable specification

CLS15

CLS15 is connected to the transmitter using the special measuring cable CYK71 or CYK71-Ex or the fixed cable.

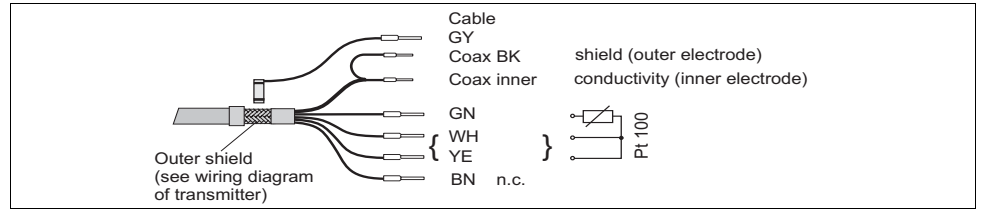

Special measuring cable CYK71 / CYK71-Ex or fixed cable

CLS15D

CLS15D connected to the transmitter using the special measuring cable CYK10.

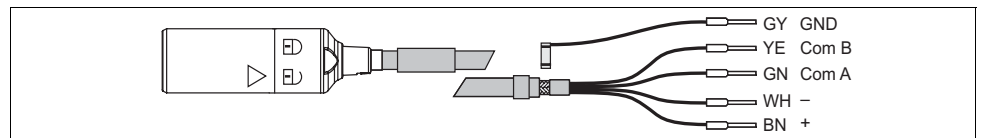

Special measuring cable CYK10

Performance characteristics

Maximum measured error

Each individual sensor is factory measured in a solution of approx. 5 $\mu\text{S}/\text{cm}$ for cell constant 0.01 cm^{-1} or approx. 50 $\mu\text{S}/\text{cm}$ for cell constant 0.1 cm^{-1} on a reference measuring system referred to NIST or DKD. The accurate cell constant is entered in the supplied quality certificate. The maximum measured error in cell constant determination is 1.0%.

Installation

Installation instructions

The sensors are mounted directly via the thread NPT 1/2" or 3/4" or clamp 1-1/2" process connections. Optionally, the sensor can be installed in cross or T-pieces or in a flow chamber.

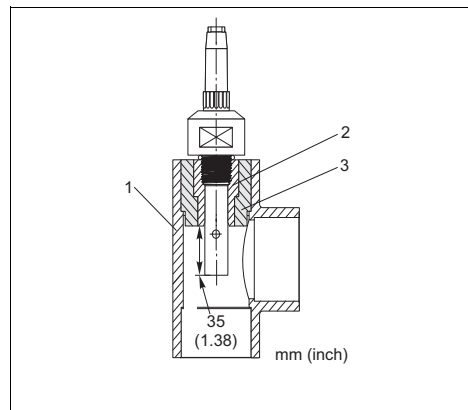

CLS15 with NPT 1/2" process connection installed in commonly used T- or cross piece

- 1 T- or cross piece (DN 32, 40 or 50)
- 2 PVC-threaded coupling for cementing (NPT 1/2" for DN 20, see Accessories)
- 3 Adapter coupling for cementing (for DN 32, 40 or 50, see Accessories)

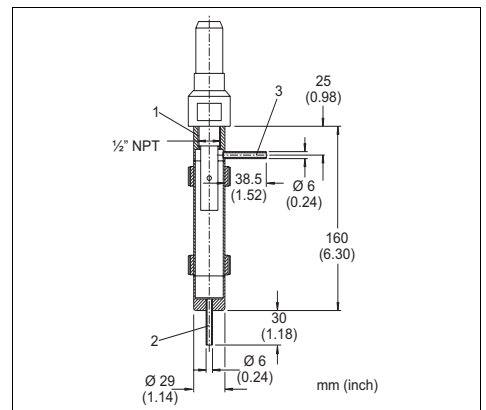

CLS15 with NPT 1/2" process connection installed in flow assembly 71042405 (see Accessories)

- 1 Sensor support NPT 1/2"
- 2 Inlet
- 3 Outlet

The measuring surfaces of the sensor must be completely immersed in the medium during operation. Minimum immersion depth is 32 mm (1.26").
 When working in ultrapure water, ingress of air must be prevented since dissolved air, particularly CO₂, may increase conductivity by up to 3 μS/cm.

Environment

Ingress protection	CLS15:	IP 67 (≅ NEMA 6)
	CLS15D:	IP 68 (≅ NEMA 6)

Process

Process temperature	CLS15	
	Thread version with fixed cable	-20 to 100°C (-4 to 212°F)
	Thread version with plug-in head, clamp version	
	Normal operation:	-20 to 120°C (-4 to 248°F)
Sterilization (max. 1 h):	max. 140°C (284°F)	

CLS15D	Normal operation:	-20 to 120°C (-4 to 248°F)
	Sterilization (max. 1 h):	max. 140°C (284°F)
	 Note!	
	The maximum temperature for communication with the transmitter is 130°C (266°F).	

Process pressure	12 bar at 20°C (174 psi at 68°F)
-------------------------	----------------------------------

Pressure/temperature load curves

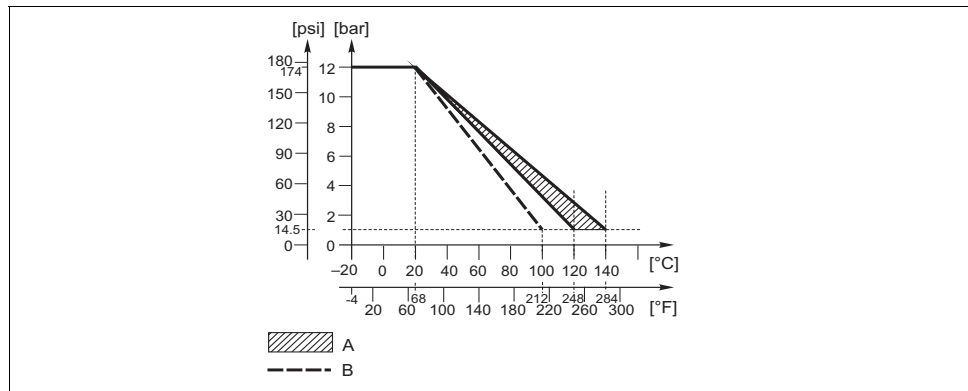

Mechanical pressure-temperature stability of the sensor

- A Short-time sterilizable (1 h)
- B Thread version with fixed cable

Mechanical construction

Design, dimensions CLS15

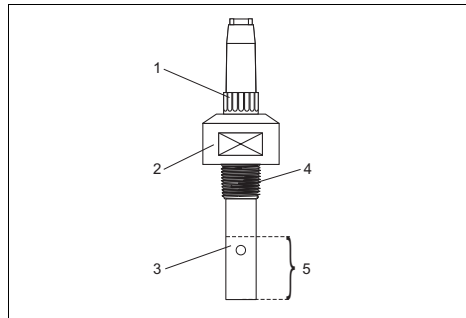

a0006146

Plug-in head version with NPT 1/2 "

- 1 Connector
- 2 Plug-in head
- 3 Coaxial measuring electrode
- 4 Thread NPT 1/2"
- 5 Minimum immersion depth

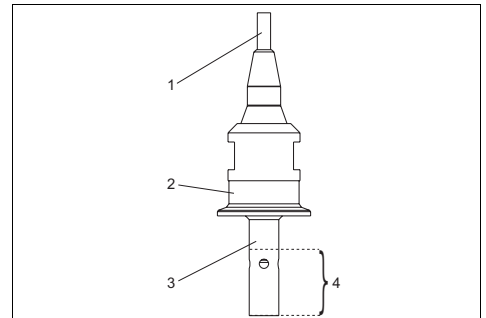

a0006145

Fixed-cable version with clamp 1-1/2"

- 1 Fixed cable
- 2 Clamp 1-1/2"
- 3 Coaxial measuring electrode
- 4 Minimum immersion depth

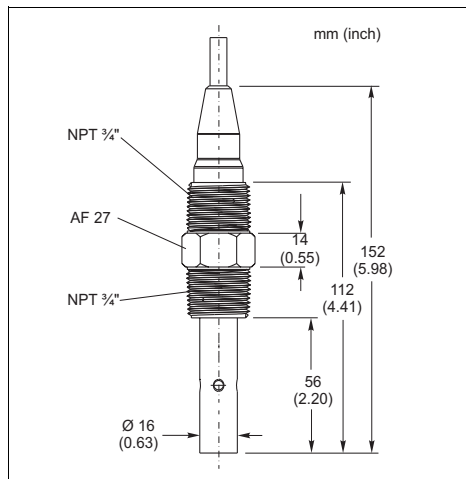

a0006149

Dimensions of fixed-cable version with NPT 3/4"

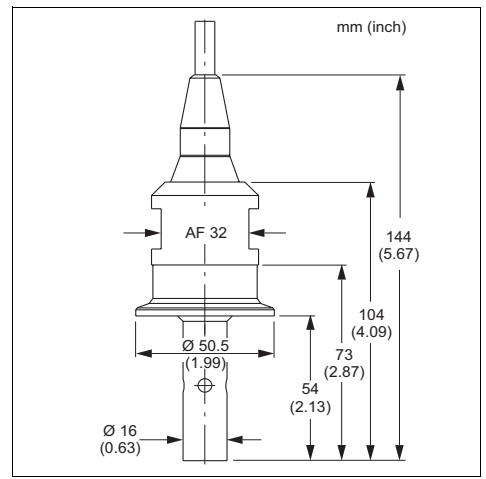

a0006147

Dimensions of fixed-cable version with clamp 1-1/2"

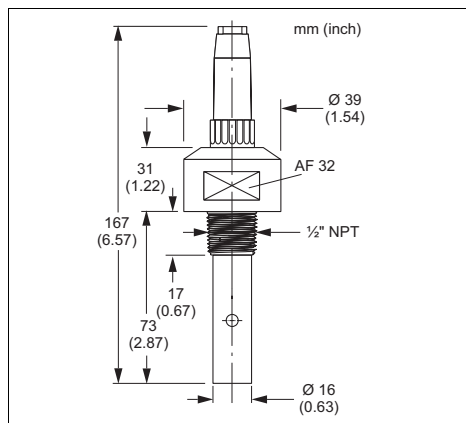

a0006150

Dimensions of plug-in head version with NPT 1/2"

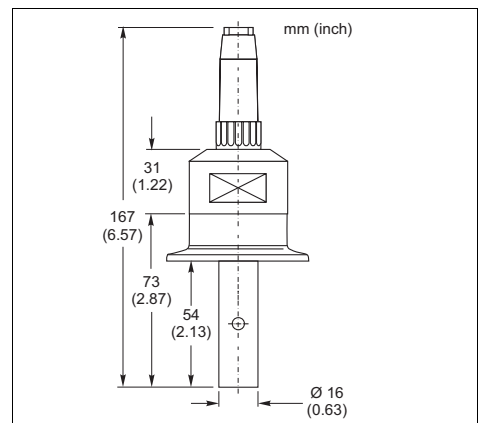

a0006148

Dimensions of plug-in head version with clamp 1-1/2"

Design, dimensions CLS15D

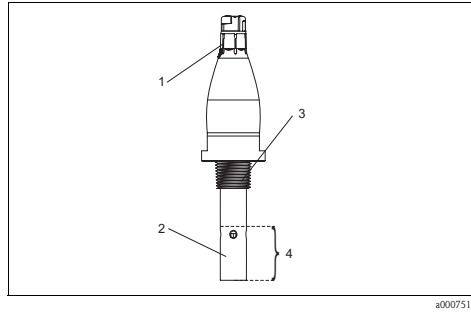

Version with thread NPT 1/2"

- 1 Memosens plug-in head
- 2 Coaxial measuring electrode
- 3 NPT 1/2" thread
- 4 Minimum immersion depth

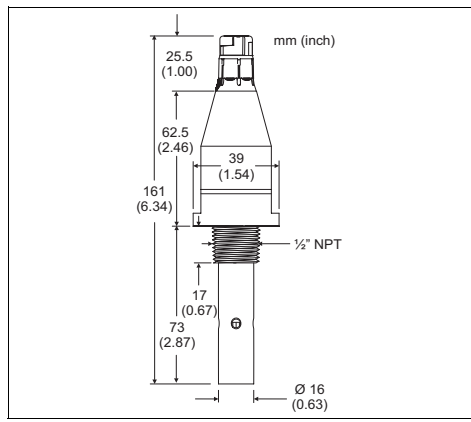

Dimensions of version with NPT thread

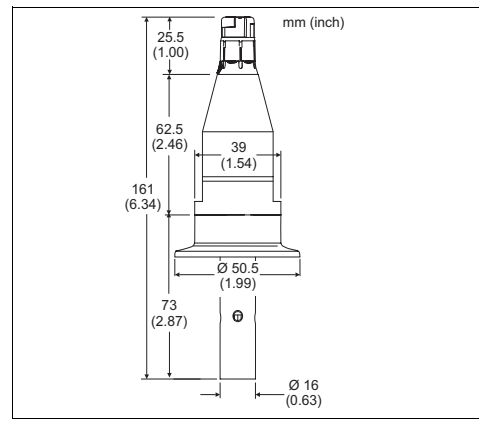

Dimensions of version with clamp

Weight Depending on version, approx. 0.3 kg (0.7 lb.)

Materials
 Electrodes: polished, stainless steel 1.4435 (AISI 316L)
 Sensor shaft: polyethersulfone (PES-GF20)
 O-ring, in contact with medium (clamp version only): EPDM

Surface roughness
 $R_a \leq 0.8 \mu\text{m}$
 ($R_a \leq 0.4 \mu\text{m}$ available under TSP C-LS020130-02)

Process connection
 CLS15
 Fixed-cable versions: Thread NPT 3/4", clamp 1-1/2" acc. to ISO 2852
 Plug-in head versions: Thread NPT 1/2", clamp 1-1/2" acc. to ISO 2852
 CLS15D: Thread NPT 1/2" and 3/4", clamp 1-1/2" acc. to ISO 2852

Certificates and approvals

Ex approval¹⁾

- ATEX II 1G EEx ia IIC T3 / T4 / T6
- FM/CSA in combination with the Liquiline M CM42 and Mycom S CLM153 transmitters

For all product versions listed in the product structure (see Ordering Information)



Note!

Ex versions of digital sensors with Memosens technology are indicated by an orange-red ring in the plug-in head.

1) Approval for CLS15D pending

Quality certificate With statement of the individual cell constant

Inspection certificate acc. to EN 10204 3.1 Available for clamp 1 1/2" process connection

Ordering information

Product structure CLS15

Measuring range and cell constant	
A	Measuring range: 0.04 to 20 µS/cm (k = 0.01)
B	Measuring range: 0.1 to 200 µS/cm (k = 0.1)
L	PWIS free for cell constant k = 0.1
Process connection and materials	
1A	Thread NPT 1/2", sensor shaft PES (plug-in head versions only)
1M	Thread NPT 3/4", sensor shaft PES (fixed-cable versions only)
3D	Clamp 1-1/2", stainless steel 1.4435 (AISI 316L)
4D	Clamp 1-1/2", stainless steel 1.4435 (AISI 316L), with inspection certificate EN 10204 3.1
Measuring cable connection	
1	4-pole SXP connector
2	with 5 m fixed cable (16 ft)
3	with 10 m fixed cable (33 ft)
Temperature sensor	
A	Integrated Pt 100 temperature sensor
CLS15-	complete order code

Product structure CLS15D

Measuring range and cell constant	
A	Measuring range: 0.04 to 20 µS/cm (k = 0.01)
B	Measuring range: 0.1 to 200 µS/cm (k = 0.1)
L	PWIS free for cell constant k = 0.1
Process connection and materials	
1A	Thread NPT 1/2", sensor shaft PES
1M	Thread NPT 3/4", sensor shaft PES
3D	Clamp 1-1/2", stainless steel 1.4435 (AISI 316L)
4D	Clamp 1-1/2", stainless steel 1.4435 (AISI 316L), with inspection certificate EN 10204 3.1
Approval	
G	ATEX II 1G EEx ia IIC T4/T6
1	Non-hazardous area
CLS15D-	complete order code

Accessories

Installation For sensors with NPT 1/2" process connection (CLS15-x1Axx):

Threaded couplings

PVC-threaded coupling

- For cementing in standard PVC cross or T-pieces with DN 20
- with G 1/2" internal thread, self-sealing with 1/2" NPT sensor thread
- order no. 50066536

PVDF-threaded coupling

- With G 1/2" internal thread and G 1 external thread
- pressure-proof up to 12 bar at 20°C (174 psi at 68°F), max. temperature 120°C at 1 bar (248°F at 14.5 psi), incl. O-ring
- internal thread, self-sealing with NPT 1/2" sensor thread
- order no. 50004381

Equalizing sleeves

PVC equalizing sleeves AM

- For adaptation of the PVC-threaded coupling to larger nominal diameters

- Diameters, order numbers:
 - AM 32: for installation into cross or T-pieces DN 32, order no. 50004738
 - AM 40: for installation into cross or T-pieces DN 40, order no. 50004739
 - AM 50: for installation into cross or T-pieces DN 50, order no. 50004740

Flow assemblies

Flow assembly

- For installation of conductivity sensors with NPT 1/2" thread
- Material: stainless steel 1.4404 (AISI 316 L)
- Inlet and outlet: 90°, Ø 6 mm (0.24")
- Volume: 0.69 l (0.18 US gal)
- Max. temperature: 100°C (212°F)
- Max. pressure: 16 bar (232 psi)
- Order no.: 71042405

Connection

Measuring cables

CYK71 measuring cable

- Non-terminated cable for the connection of sensors (e.g. conductivity sensors) or the extension of sensor cables
- Sold by the meter, order numbers:
 - non-Ex version, black: 50085333
 - Ex version, blue: 51506616

CYK10 Memosens data cable

- For digital sensors with Memosens technology
- Ordering according to product structure, see below

Certificates	
A	Standard, non Ex
G	ATEX II 1G EEx ia IIC T6/T4
Cable length	
03	Cable length: 3 m (9.8 ft)
05	Cable length: 5 m (16 ft)
10	Cable length: 10 m (33 ft)
15	Cable length: 15 m (49 ft)
20	Cable length: 20 m (66 ft)
25	Cable length: 25 m (82 ft)
88	... m length
89	... ft length
Ready-made	
1	Wire terminals
CYK10-	complete order code

CYK81 measuring cable

- Non-terminated measuring cable for extension of sensor cables of e.g. Memosens, CUS31/CUS41
- 2 wires, twisted pair with shield and PVC-sheath (2 x 2 x 0.5 mm² + shield)
- Sold by the meter, order no. 51502543

Junction boxes

Junction box VBM

- For cable extension
- 10 terminals
- Cable entries: 2 x Pg 13.5 or 2 x NPT ½"
- Material: aluminum
- Ingress protection: IP 65 (≅ NEMA 4X)
- Order numbers:
 - cable entries Pg 13.5: 50003987
 - cable entries NPT ½": 51500177

Junction box VBM-Ex

- For cable extension in hazardous areas
- 10 terminals (blue)
- Cable entries: 2 x Pg 13.5
- Material: aluminum
- Ingress protection: IP 65 (≅ NEMA 4X)
- Order no.: 50003991

Junction box RM

- For cable extension (e.g. for Memosens sensors or CUS31/CUS41)
- 5 terminals
- Cable entries: 2 x Pg 13.5
- Material: PC
- Ingress protection: IP 65 (≅ NEMA 4X)
- Order no.: 51500832

Transmitters

Liquiline M CM42 (for analog conductivity sensors and digital conductivity sensors with Memosens technology)

- Modular two-wire transmitter for Ex and non-Ex areas
- Hart®, PROFIBUS or FOUNDATION Fieldbus available
- Ordering acc. to product structure, see Technical Information (TI381C/24/ae)

Liquisys M CLM223/253 (for analog conductivity sensors)

- Transmitter for conductivity, field or panel-mounted housing,
- Hart® or PROFIBUS available
- Ordering acc. to product structure, see Technical Information (TI193C/24/ae)

Mycom S CLM153 (for analog conductivity sensors)

- Transmitter for conductivity, one or two channel version, Ex or Non-Ex,
- Hart® or PROFIBUS available
- Ordering acc. to product structure, see Technical Information (TI234C/24/ae)

Calibration solutions

Precision solutions referred to SRM (Standard Reference Material) of NIST for qualified calibration of conductivity measuring systems according to ISO, with temperature table,

- CLY11-A
74 µS/cm (reference temperature 25°C (77°F)), 500 ml (16.9 fl.oz);
order no. 50081902
- CLY11-B
149.6 µS/cm (reference temperature 25°C (77°F)), 500 ml (16.9 fl.oz);
order no. 50081903

Calibration sets

Concal calibration set

- conductivity calibration set for ultrapure water applications
- complete, factory-calibrated measuring set with certificate, traceable to SRM of NIST and DKD
- for comparative measurement in ultrapure water applications up to max. 10 µS/cm
- order numbers, versions:
 - 230 V AC: 50083777
 - 115 V AC: 50083778

Recalibration Concal

- factory recalibration and new issue of calibration certificate, traceable to SRM of NIST and DKD
- factory calibration procedure according to ASTM D-5391-93
- order no. 5150248

United States

Endress+Hauser, Inc.
 2350 Endress Place
 Greenwood, IN 46143
 Tel. 317-535-7138
 Sales 888-ENDRESS
 Service 800-642-8737
 fax 317-535-8498
 inquiry@us.endress.com
 www.us.endress.com

Canada

Endress+Hauser Canada
 1075 Sutton Drive
 Burlington, ON L7L 5Z8
 Tel. 905-681-9292
 800-668-3199
 Fax 905-681-9444
 info@ca.endress.com
 www.ca.endress.com

Mexico

Endress+Hauser, México, S.A. de C.V.
 Fernando Montes de Oca 21 Edificio A Piso 3
 Fracc. Industrial San Nicolás
 54030. Tlalnepantla de Baz
 Estado de México
 México
 Tel: +52 55 5321 2080
 Fax +52 55 5321 2099
 eh.mexico@mx.endress.com
 www.mx.endress.com

TI109C/24/ae/10.07
 © 2007 Endress+Hauser, Inc.