

L404F,T,V PressureTrol® Controllers

PRODUCT DATA



FEATURES

- Models available in a series of control ranges, and pressure scales in kPa and psi.
- All models automatically reset and have an adjustable differential.
- Models have snap switch to open or close a circuit on a pressure rise.
- Case has a clear plastic cover so setpoints can be observed.
- 1/4 inch—18 NPT connection for pipe on diaphragm assembly.
- Ground screw terminal.

L404F:

- Controllers may be used with steam, air, or noncombustible gases, or fluids noncorrosive to the pressure sensing element.

L404T:

- High pressure limits, break a circuit on oil pressure rise above setpoint.

L404V:

- Low pressure limits, makes a circuit on oil pressure rise above setpoint.

APPLICATION

L404F PressureTrol® Controllers provide operating control with automatic limit protection for pressure systems of up to 2070 kPa, or 300 psi.

L404T,V PressureTrol® Controllers are for use on oil burner systems for pressures up to 1035 kPa or 150 psi.

Contents

Application	1
Features	1
Specifications	2
Ordering Information	2
Installation	4
Settings and Adjustments	6
Checkout	7



SPECIFICATIONS

Model:

L404F,T,V PressureTrol® Controllers. See Table 1.

Table 1. Models with kPa—psi and Other Pressure Scales.

Model Number	Operating Ranges		Subtractive Differential ^a		Maximum Diaphragm pressure	
	kPa	psi	kPa	psi	kPa	psi
L404F1060	15 to 100	2 to 15	15 to 40	2 to 6	170	25
L404F1078	35 to 350	5 to 50	40 to 100	6 to 14	590	85
L404F1094	140 to 2070	20 to 300	140 to 345	20 to 50	2410	350 ^b
L404F1102	70 to 1035	10 to 150	70 to 150	10 to 22	1550	225
L404F1219 ^c	15 to 100	2 to 15	15 to 40	2 to 6	170	25
L404F1243 ^c	35 to 350	5 to 50	40 to 100	6 to 14	590	85
L404F1227 ^c	70 to 1035	10 to 150	70 to 150	10 to 22	1550	225
L404F1235 ^c	140 to 2070	20 to 300	140 to 345	20 to 50	2410	350 ^b
L404F1300 ^c	415 to 1240	60 to 180	40 fixed	6.0 Fixed	1550	225
L404F1326	0 to 100	0 to 15	15 to 40	2 to 6	170	25
L404F1334	0 to 350	0 to 50	40 to 100	6 to 14	590	85
L404F1342	35 to 1000	5 to 145	70 to 150	10 to 22	1550	225
L404F1359	70 to 2000	10 to 290	140 to 345	20 to 50	2410	350 ^b
L404F1367	7 to 55	1 to 8	5 to 14	0.75 to 2	170	25
L404F1375 ^d	35 to 350	5 to 50	40 to 100	6 to 14	590	85
L404F1383 ^d	70 to 1035	10 to 150	70 to 150	10 to 22	1550	225
L404F1391 ^d	140 to 2070	20 to 300	140 to 345	20 to 50	2410	350 ^b
L404F1409 ^d	15 to 100	2 to 15	15 to 40	2 to 6	170	25
L404F1441	0.35 to 3.5 Kg/cm ²	5 to 50 psi	0.4 to 1.0 Kg/cm ²	6 to 14 psi	6 Kg/cm ²	85 psi
L404T1055	35 to 350	5 to 50	40 to 100	6 to 14	590	85
L404T1063	70 to 1035	10 to 150	70 to 150	10 to 22	1550	225
L404V1087 ^d	70 to 1035	10 to 150	70 to 150	10 to 22	1550	225
L404V1095 ^d	35 to 350	5 to 50	40 to 100	6 to 14	590	85

^a Nominal at midscale operating range.^b Brass bellows instead of stainless steel diaphragm.^c Models with 1/4-19 BSPT thread instead of 1/4-18 NPT thread.^d Make-on-rise models with terminal B omitted for miswiring compliance.

ORDERING INFORMATION

When purchasing replacement and modernization products from your TRADELINE® wholesaler or distributor, refer to the TRADELINE® Catalog or price sheets for complete ordering number.

If you have additional questions, need further information, or would like to comment on our products or services, please write or phone:

1. Your local Honeywell Automation and Control Products Sales Office (check white pages of your phone directory).
2. Honeywell Customer Care
1885 Douglas Drive North
Minneapolis, Minnesota 55422-4386

In Canada—Honeywell Limited/Honeywell Limitée, 35 Dynamic Drive, Toronto, Ontario M1V 4Z9.

International Sales and Service Offices in all principal cities of the world. Manufacturing in Australia, Canada, Finland, France, Germany, Japan, Mexico, Netherlands, Spain, Taiwan, United Kingdom, U.S.A.

Table 2. Conversion Table.

Operating Range Conversions			Subtractive Differential Conversions		
kg/cm ²	kPa	psi	kg/cm ²	kPa	psi
0.1 to 1.05	15 to 100	2 to 15	0.15 to 0.4	15 to 40	2 to 6
0.4 to 3.5	35 to 350	5 to 50	0.4 to 1.0	40 to 100	6 to 14
0.7 to 10.0	70 to 1035	10 to 150	0.7 to 1.6	70 to 150	10 to 22
1.5 to 20.0	140 to 2070	20 to 300	1.5 to 3.5	150 to 300	20 to 50

Table 3. Switch Ratings (Amperes).

Switch State	120 Vac	240 Vac
Full Load	8.0	5.1
Locked Rotor	48.0	30.6

Pressure Sensing Element: Stainless steel diaphragm (140 to 2070 kPa models) has brass bellows.

Maximum Ambient Temperature: 66°C (150°F). Also, refer to note under Mounting.

Adjustment Means: Screws on top of control case. Scales are marked in psi or kPa.

Mounting Means: 1/4 inch-18 NPT connection on diaphragm assembly; or surface mounts using holes in back of case.

Dimensions: See Fig. 1.

Switching Action: Snap switch breaks R-B (closes R-W) on pressure rise. Make-on-rise devices omit terminal B.

Grounding Means: Ground screw terminal marked with a circled ground symbol.

Accessories:

- 50024585-001 Brass Steam Trap. (Please refer to the applicable Equipment/Application Standards for compliance.)
- 14026 Steel Steam Trap. (Please refer to the applicable Equipment/Application Standards for compliance.)
- 118023 Steel Steam Trap for BSPT Models.
- 33312B Knurled Knob—fits on top of adjusting screws.
- 4074BWJ Range Stop—range stop screw, Part No. 107194, and wrench, Part No. 23466, to limit setpoint range.

Approvals:

- Underwriters Laboratories Inc. Listed: file no. MP466, vol. 10, guide no. MBPR.
- Canadian Standard Association certified: file no. LR1620, guide no. 400E-0.

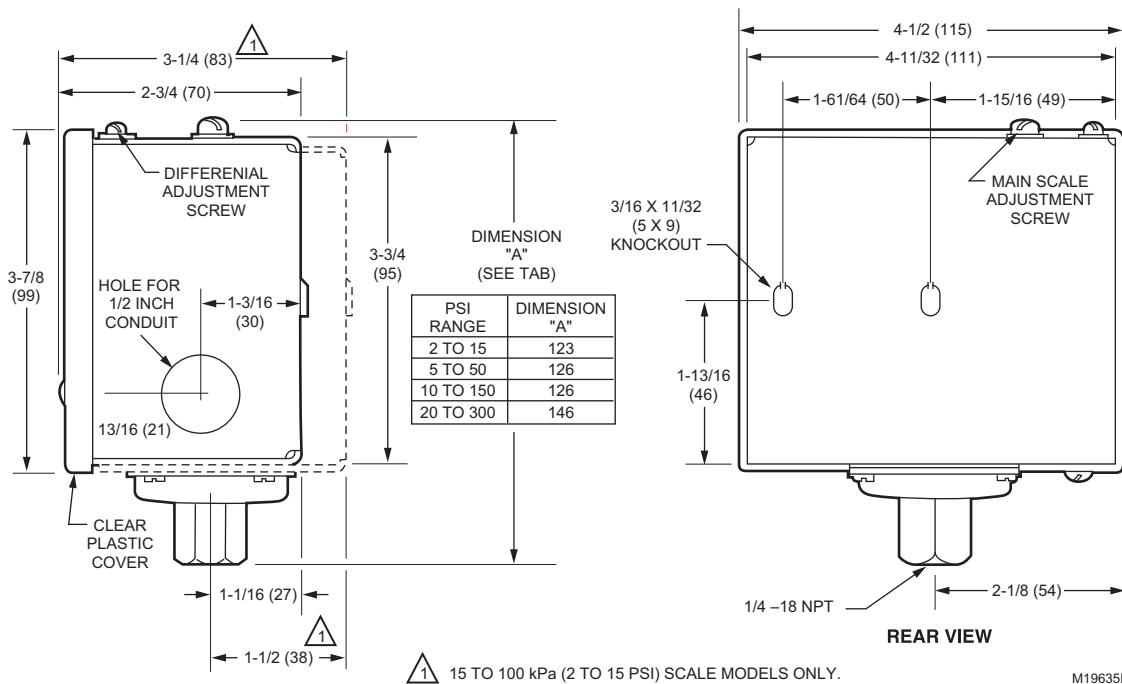

Fig. 1. L404F,T,V approximate dimensions in inches (millimeters in parentheses).

INSTALLATION

When Installing This Product...

1. Read these instructions carefully. Failure to follow them could damage the product or cause a hazardous condition.
2. Check on the ratings given in the instructions and marked on the product to make sure the product is suitable for your application.
3. Installer must be a trained, experienced service technician.
4. After installation is complete, check out the product operation as provided in these instructions.

IMPORTANT

When making pipe connections, use pipe dope sparingly to seal the joints; any excess dope may clog the small hole in the fitting and prevent the controller from operating properly.

Location and Mounting (L404F)

Locate the L404F where the ambient temperature will not exceed 66°C (150°F). The L404F can be mounted near the pressure gauge, at a remote location, in a fitting provided by the boiler manufacturer, or in a special mounting on low water cutoffs. The L404F should always be mounted above the water line in steam boiler applications.

NOTE: For accurate operation, supplemental heat should be added to installations where temperatures fall below -29°C (-20°F).

A steam trap must be connected between the L404F and the boiler (see Fig. 2) to prevent boiler scale and corrosive vapors from attacking the elbows or diaphragm.

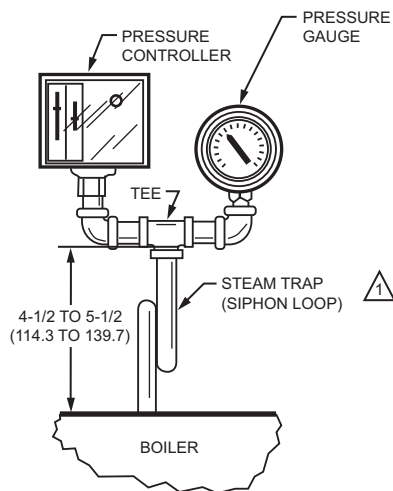

1 1/4 IN. PIPE WITH 1/4 - 18 NPT EXTERNAL THREADS ON BOTH ENDS AND 2-1/4 IN. DIAMETER LOOP.

M23885

Fig. 2. Steam trap mounting.

Pressure Gauge Mounting

To mount beside a pressure gauge, remove the gauge, and install in its place the steam trap with a tee on top. Mount the PressureTrol® unit and pressure gauge on the side of the tee by means of nipples and elbows (see Fig. 2).

Remote Mounting

Excessive vibration at the boiler may affect the operation of the L404F. In these cases, the L404F should be remotely located, subject to the following:

1. All piping must be suitable and properly pitched to drain all condensation back to the boiler.
2. The remote mounting must be solid.
3. A steam trap must be used at one end of the piping.

Boiler Mounting

If it is not convenient to mount the L404F adjacent to the pressure gauge, install a steam trap at the location recommended by the boiler manufacturer, then screw the device directly to the steam trap.

Location and Mounting (L404T,V)

Location

NOTE: For most accurate operation, supplemental heat should be added to installations where the temperature falls below -20°F (-29°C). These controllers can be mounted at any location in the oil supply line, depending on the application. Typical locations are shown in Fig. 3. The low oil pressure controller should be located upstream from the safety shutoff valve(s). In a downstream location, there would be zero pressure when the burner is not running and the safety shutoff valve(s) is (are) closed. This could prevent startup or require manual reset every time the burner is started. The high oil pressure controller should be located as near to the burner as possible.

Mounting

Mount the oil pressure controller directly on the main pipe. Insert a tee in the pipe line, and connect a pipe nipple of appropriate size to the tee (see Fig. 4). Screw the hexagonal fitting (1/4-18 NPT internal thread) of the pressure controller to the pipe nipple. To avoid leaks and damage to the case, use a parallel jaw wrench on the hexagonal fitting close to the pipe nipple. Do not tighten the pressure controller by hand by holding the case.

Make all pipe connections in accordance with approved standards. Use only a small amount of pipe compound to seal the connection joints. Excess pipe compound may clog the orifice in the pipe fitting and prevent the controller from operating properly.

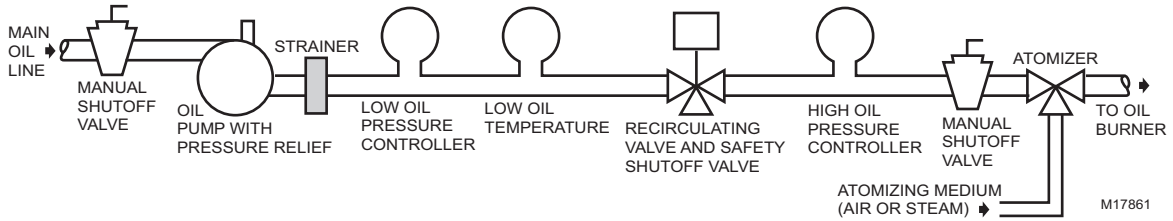

Fig. 3. Typical locations of pressure controllers in an oil burner system.

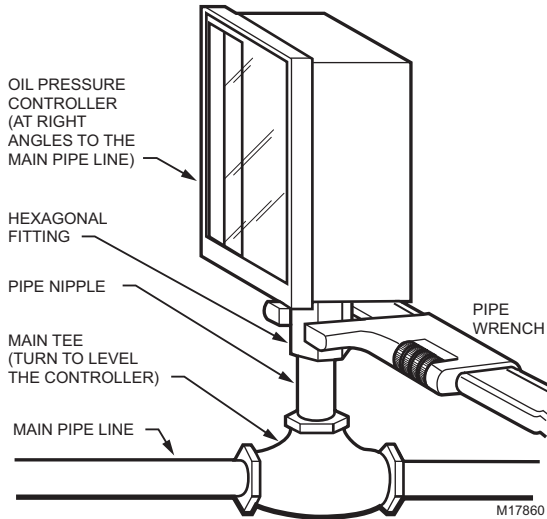
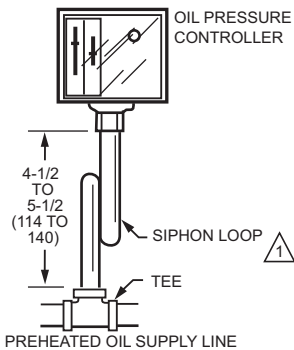

Fig. 4. Mounting an oil pressure controller directly on the main pipe.

Using with Preheated Oil

When used with preheated oil, a siphon loop must always be connected between the controller and the main pipe (see Fig. 5) to provide thermal buffering.



1 1/4 INCH PIPE WITH 1/4-18 NPT EXTERNAL THREADS ON BOTH ENDS AND 2-1/4 IN. (57 MM) DIAMETER LOOP.

M23886

Fig. 5. Mounting of a siphon loop, with approximate dimensions in in. (mm).

WIRING

⚠ WARNING

Electrical Shock Hazard.

Can cause severe injury, death or property damage.

Disconnect the power supply before beginning wiring. More than one power supply disconnect may be required.

All wiring must comply with applicable codes and ordinances. All models have terminals (on the MicroSwitch® snap-acting switch) inside the cover and knockouts for conduit and cable. Refer to manufacturer installation and wiring instructions, if available, and to typical hookups shown in Fig. 6 to 10.

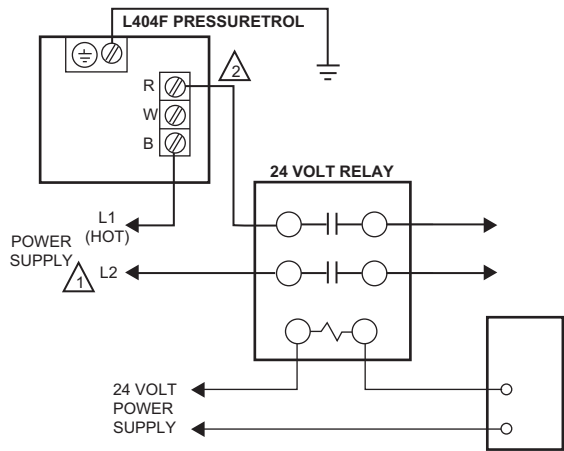

1 PROVIDE DISCONNECT MEANS AND OVERLOAD PROTECTION AS REQUIRED.

2 AS SHOWN, SWITCH OPENS ON PRESSURE RISE. REVERSE ACTING (MAKE ON PRESSURE RISE) UNITS ARE WIRED TO R-W TERMINALS AND TERMINAL B IS OMITTED.

M19637A

Fig. 6. L404F in low voltage relay circuit.

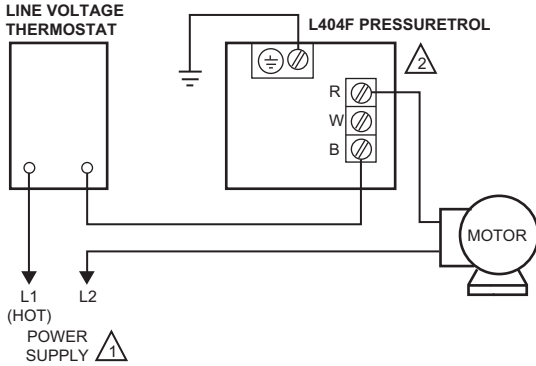

- 1 PROVIDE DISCONNECT MEANS AND OVERLOAD PROTECTION AS REQUIRED.
- 2 AS SHOWN, SWITCH OPENS ON PRESSURE RISE. REVERSE ACTING (MAKE ON PRESSURE RISE) UNITS ARE WIRED TO R-W TERMINALS AND TERMINAL B IS OMITTED.

M19638A

Fig. 7. L404F in a typical 2-wire control circuit.

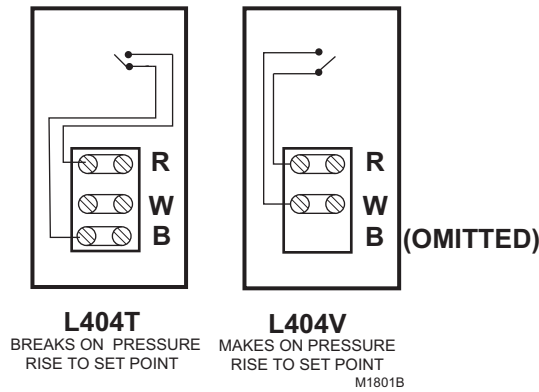
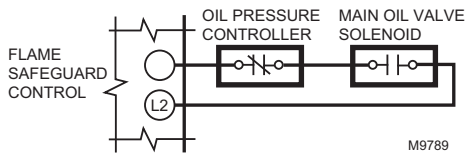
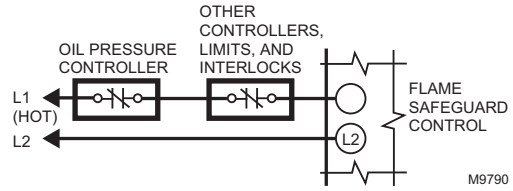

Fig. 8. L404T,V terminal blocks and internal schematics.



M9789

Fig. 9. Hookup of an oil pressure controller used on a single burner system with an integral oil pump.



M9790

Fig. 10. Hookup of an oil pressure controller used on a single burner or multiburner system with an external oil pump.

SETTINGS AND ADJUSTMENTS

When the pressure at the control rises above the L404 setpoint, a circuit opens between the R-B terminals. During a pressure rise, R-B will close at the setpoint pressure minus the switch differential.

For example, if a controller is set to differential **B** (see Fig. 11) with a controller setpoint of **A**, R-B will open when the pressure rises to **A**. Then during a pressure fall, the R-B terminals will close when the pressure drops to **C** (**A** minus differential **B**).

For make on rise applications, the switch is wired to R-W terminals. The R-W circuit will close on pressure rise to the setpoint. R-W will open again on a pressure drop past the switch differential.

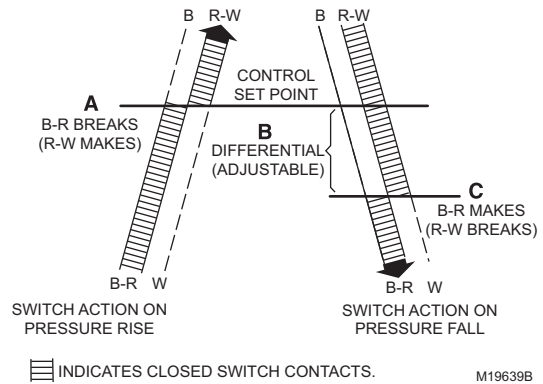

Fig. 11. Operation of switch on pressure rise and fall.

Setpoint Adjustment

Turn the pressure adjusting screw on the top of the controller (Fig. 12) to adjust the setpoint. Turn the differential adjusting screw to the desired pressure difference between switch opening and switch closing.

NOTE: When the main scale setting is at the lower end of the operating range, the differential range will be less than the differential setting by approximately 20 percent.

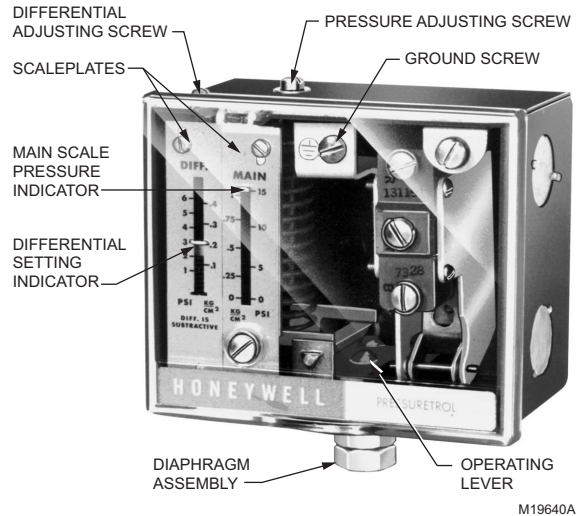

Fig. 12. view of L404 PressureTrol® Controller.

Scaleplate Adjustment

The L404F,T,V has been carefully calibrated during manufacture and should not require recalibration.

However, if recalibration is necessary, remove the cover and loosen the setscrews which hold the scaleplate. Adjust the plate up or down, as required, to bring the device into calibration. Tighten the setscrews securely and replace the cover.

CHECKOUT

After the controller has been installed, wired and adjusted, it should be tested with the system in operation. First, allow the system to stabilize. Then, observe the operation of the controller while raising and lowering its setpoint. Pressure should increase when the setpoint is raised and decrease when the setpoint is lowered.

Also, check the make and break points of the controller. If they do not agree with a separate, accurately calibrated pressure gauge, a slight adjustment of the scaleplate(s) may be necessary.

Use accurate pressure testing equipment when checking out the controller. Do not rely on inexpensive gauges. The controllers are carefully calibrated at the factory.