

Product Data Sheet

PS-001056, Rev. G

April 2013

Micro Motion® 7826/7828 Series Density and Concentration Meters

Micro Motion® density and concentration meters are built to tackle the most demanding process and fiscal applications. Rugged and reliable direct insertion meters with very low maintenance, they provide fully integrated “fit and forget” density measurement.



7835 Peak performance density meter

7845 High performance general purpose density meter

7847 High accuracy hygienic density meter

7826/28 Direct insertion density meter

3098 Gas specific gravity meter

7812 Fiscal gas density meter

High accuracy density measurement

- Unique direct insertion design in lengths up to 13 ft (4 m)
- Integral-mount transmitter with analog and digital communications
- Onsite ISO17025-accredited density laboratory for guaranteed performance

Greatest installation flexibility

- Continuous, real-time measurement in pipelines, slipstreams, and tanks
- Wide range of corrosion-resistant materials

Superior reliability and safety

- Optimized design – insensitive to vibration, temperature, and pressure variations



Micro Motion 7826/7828 density and concentration meters

About the 7826 and 7828

The Micro Motion 7826 and 7828 liquid density meters are ideal for measuring most liquids in tank and pipeline applications. They can be used in process control where density is the primary control parameter for the end product, or as an indicator of some other quality control parameter such as % solids or % concentration. Each meter offers features that are suited to specific application requirements.

Liquid density meter	Electronics options		Entrained gas	Maximum liquid viscosity
	Raw frequency output	Advanced with Modbus communications		
7826	✓	✓	Recommended	500 cP
7828	--	✓	Generally not used	20,000 cP

Advantages

- Fully integrated “fit and forget” digital measurement for monitoring and control
- Continuous measurement
- No moving parts means virtually no maintenance
- Corrosion resistant materials including Zirconium, Alloy 400, Alloy B3, and Alloy C22
- Direct mA (4–20 mA) output of density, base density, or special calculations (% solids, °API, specific gravity)
- Modbus / RS-485 communications
- Integral Class B RTD temperature sensor
- Hazardous-area approved (ATEX and CSA)
- Long-stemmed version is suitable for use on open and closed tanks
- Long-stem lengths up to 13 ft (4 m)
- Tolerant of solids and bubbles
- Insensitive to vibration
- Direct insertion meter suitable for high-line pressure
- PC configuration tools for diagnostics and data logging

Contents

Typical applications	3	General classifications	8
Typical industries	3	Materials of construction	8
Principle of operation	3	Weight	8
Features	3	Electrical	9
Liquid and material compatibility	5	Dimensions	10
Density performance	6	Installation	13
Temperature specification	6	7826 Ordering information	14
Pressure ratings	7	7828 Ordering information	16
Hazardous area classifications	7		

Typical applications

- Interface detection in multi-product pipelines
- Petroleum retail outlets (long-stemmed 7826 or 7828 only)
- Mass flow when used in conjunction with a volumetric flow meter
- Sugar refining (°Brix)
- Wort gravity (Brewing)
- Slurries
- Acid/Alkali concentration control
- Evaporator control
- Product mixing
- End-point detection in batch reactions
- Solvent separation

Typical industries

- Oil and petrochemical
- Brewing
- Organic and inorganic chemicals
- Pharmaceutical
- Minerals processing (clays, carbonates, silicates)

Principle of operation

The 7826 and 7828 liquid density meters use a vibrating fork to measure density. The density of the liquid in which the fork tines vibrate changes the resonant frequency of the meter. By monitoring this resonant frequency and applying well-known conversions, the 7826/7828 can provide highly accurate inline density measurement.

Features

The 7826 and 7828 liquid density forks are highly accurate, factory-calibrated meters that do not require field calibration. All factory calibrations are traceable to UK national standards through the Micro Motion onsite ISO17025-accredited laboratory.

For information on the liquid and material compatibility of the 7826/7828 meters, see “Liquid and material compatibility” on page 5.

7826 frequency output version

The 7826 with frequency output measures line density and temperature, which can then be used to calculate base density using API tables or a matrix referral as well as parameters such as °API and specific gravity. Calculations are performed in conjunction with a Micro Motion Model 7950 or Model 7951 signal converter. Any of these parameters can be used to drive mA outputs from the signal converter. See “Model 7950 and Model 7951 Signal Converters (7826 only)” on page 4.

7826/7828 Advanced electronics version

The 7826/7828 with Advanced electronics features a configured microprocessor-based electronic module which places the full signal conditioning, calculation, and diagnostic facilities within the transmitter itself. Remote electronics are not required for signal processing.

This meter measures line density and temperature, and calculates base density using API tables or a matrix referral as well as parameters such as °API, °Brix, % solids, % concentration, % mass, % volume and specific gravity (a user-defined equation calculation is available). Any of these parameters can be used to drive the integral mA (4–20 mA) outputs, enabling them to be used as the process variable in control applications without the need for additional processing electronics.

The default settings for the two mA outputs vary according to the product option code:

Code	A	B	C and D
mA output 1	Special function (°API)	Referred density (kg/m ³)	Line density (kg/m ³)
4 mA	0	700	700
20 mA	100	1000	1000
mA output 2	Temp (°C)	Temp (°C)	Temp (°C)
4 mA	0	0	0
20 mA	150	150	150

All measurements are available digitally via the built-in Modbus/RS-485 communications interface, for integration into plant data systems. You can use ADView or ProLink II software to configure or diagnose the meter via the Modbus/RS-485 interface. [See “ADView (7826/7828 Advanced only)” and “ProLink II (7826/7828 Advanced only)” for more information.]

Model 7950 and Model 7951 Signal Converters (7826 only)

Inputs from 7826:

- Line density (frequency)
- Temperature (PT100)

Typical 7950/7951 calculations:

- Line density
- Referred density
- Specific gravity
- % concentration

7950/7951 outputs:

- Status
- Four 4–20 mA outputs (optional: 8)
- RS-232C/485



ADView (7826/7828 Advanced only)

ADView is a PC-based configuration and diagnostics tool that runs on a Microsoft® Windows® platform, communicates with the 7826/7828 through a standard serial port, and provides the following functionality:

- Setting up a serial link to communicate with the 7826/7828 transmitter
- Configuring the 7826/7828 transmitter
- Displaying data real-time or as a graph
- Logging data to a file
- Verifying correct operation of the system and diagnosing faults
- Loading or storing Modbus register values
- Read/write to individual Modbus registers

ProLink II (7826/7828 Advanced only)

The ProLink II software tool can be used with the 7826/7828 liquid density meters. ProLink II runs on a Microsoft Windows platform, communicates with the 7826/7828 through a standard serial port or USB port, and provides the following functionality:

- Configuring the 7826/7828 transmitter
- Viewing and logging process parameters
- Viewing meter diagnostics

Liquid and material compatibility

The following table provides a guideline for the liquid and material compatibility of the 7826/7828 liquid density meters. For detailed information on material compatibility to different liquids, see the Micro Motion Corrosion Guide available at www.micromotion.com.

● Recommended ◐ Usable under certain concentration and temperature constraints ○ Generally not used

Liquid type	Name	Formula	Concentration (%)	Zirconium	Alloy B3	Alloy C22	Alloy 400	Stainless Steel
Acid	Hydrochloric acid	HCl	0-40	●	◐	◐	○	○
	Sulfuric acid	H ₂ SO ₄	0-50	◐	●	◐	◐	◐
		H ₂ SO ₄	50-75	○	◐	◐	○	○
		H ₂ SO ₄	75-98	○	◐	◐	○	◐
	Nitric acid	HNO ₃	0-100	●	◐	◐	○	◐
	Phosphoric acid	H ₃ PO ₄	0-98	◐	●	●	○	◐
Alkali	Sodium Hydroxide	NaOH	0-100	◐	●	●	●	◐
	Potassium Hydroxide	KOH	0-50	●	●	●	●	◐
	Calcium Hydroxide	CA(OH) ₂	0-50	○	●	●	●	◐
Other	Urea (carbamide)	(NH ₂) ₂ CO	0-100	●	○	●	○	●
	Sodium Hypochlorite	NaOCl	0-16	◐	○	◐	○	○
	Hydrogen Peroxide	H ₂ O ₂	0-90	◐	◐	●	◐	●

Density performance

Accuracy ⁽¹⁾	±0.001 g/cc	±1.0 kg/m ³	
Operating Range ⁽²⁾	0 to 3 g/cc	0 to 3000 kg/m ³	0 to 187.4 lb/ft ³
Repeatability	±0.0001 g/cc	±0.1 kg/m ³	±0.006 lb/ft ³
Process Temperature Effect (Corrected) ⁽³⁾	±0.0001 g/cc	±0.1 kg/m ³	(Per °C)
Process Pressure Effect (Corrected) ⁽⁴⁾	Negligible		

(1) Stated accuracy is for calibrated range 0.6–1.25 g/cc (600–1250 kg/m³).

(2) With the 7826, the viscosity of the liquid can be up to a maximum of 500 cP. However, with the 7828, the viscosity of the liquid can be up to a maximum of 20,000 cP.

(3) Temperature effect is the maximum measurement offset due to process fluid temperature changing away from the factory calibration temperature.

(4) Pressure effect is defined as the change in sensor flow and density sensitivity due to process pressure changing away from the calibration pressure. To determine factory calibration pressure, refer to calibration document shipped with the 7826/7828. If data is unavailable, contact the factory.

Temperature specification

Process	7826/7828 short-stem version 7826/7828 long-stem version	–58 °F to +392 °F (–50 °C to +200 °C) –40 °F to +302 °F (–40 °C to +150 °C)
Ambient	–40 °F to +185 °F (–40 °C to +85 °C)	

Integral temperature sensor

Technology	100-Ω RTD (4 wire)
Accuracy	PT100 BS1904 Class B, DIN 43760 Class B.

Pressure ratings

Maximum operating pressure ^{(1) (2)}	7826/7828 short-stem version	3000 psi (207 bar)
	7826/7828 long-stem version	1450 psi (100 bar)
Test pressure	Tested to 1.5 x the maximum operating pressure	
PED compliance	Outside the scope of European directive 97/23/EC on Pressure Equipment.	

(1) Actual maximum operating pressures are limited by the process connection rating.

(2) For Zirconium flanges, the maximum operating pressure is dependent on the working temperature. See "Zirconium 702 pressure and temperature flange ratings" for more information.

Zirconium 702 pressure and temperature flange ratings

Process flange type	Pressure and temperature ratings			
	37.8 °C	93.3 °C	148.8 °C	200 °C
2" ANSI 150	15.6 bar	13.6 bar	11.0 bar	7.6 bar
2" ANSI 300	40.6 bar	35.4 bar	28.8 bar	23.2 bar
DN50 PN16	15.8 bar	12.1 bar	9.5 bar	7.4 bar
DN50 PN40	39.4 bar	30.3 bar	23.6 bar	18.4 bar

Hazardous area classifications

ATEX Explosion Proof

ATEX-approved: Certification for use in Europe

7826/7828 ATEX II2G Ex d IIC, T4

CSA C-US Explosion Proof

CSA-approved: Certification for use in Canada and USA

7826/7828 Class I, Division 1 Groups C & D, T4

General classifications

Electromagnetic compatibility

All versions conform to the latest international standards for EMC, and are compliant with EN 61326/IEC 61326.

Environment

- Weather rating: IP66

Materials of construction

Wetted parts	7826 (short stem)	Stainless steel 316L, Alloy C22, Alloy B3, Alloy 400, Zirconium or Titanium
	7828 (short stem)	Stainless steel 316L, Alloy C22, Alloy B3, Alloy 400, or Titanium
	7826/7828 (long stem) ⁽¹⁾	Stainless steel 316L
Tine finish	7826/7828	Standard, PFA coated, or Electro-polished
Electronics enclosure	7826/7828 (short stem)	Sand cast low copper alloy Polyurethane paint finish
	7826/7828 (long stem)	Sand cast low copper alloy, or stainless steel Polyurethane paint finish

(1) The 7826/7828 long-stem version is also available in Alloy C22 as an ETO purchase.

Weight

Weight	7826/7828 (short stem)	15 lb (6.7 kg) typical
	7826/7828 (long stem)	Dependent on stem length (contact factory)

Electrical

Power supply requirement	7826 frequency output 7826/7828 transmitter 7826/7828 mA outputs	23 to 27 VDC, 50 mA 20 to 28 VDC, 50 mA 22 mA per output
Outputs (7826 frequency output)	Frequency output	Current modulation on power supply line 2 wires (6V peak nominal)
	PT100 output	100-Ω RTD (4 wire)
Outputs (7826/7828 Advanced electronics)	mA Accuracy Repeatability Out-of-range System alarm	Two passive 4–20 mA ±0.1% of reading, ±0.05% of full scale at 20 °C ±0.05% of full scale, over range –40 °C to +85 °C 3.9 or 20.8 mA on 4–20 mA 2 or 22 mA on 4–20 mA (Programmable alarm state)
	Communications	RS-485 (Modbus)

Dimensions

7826/7828 short stem

Cone-seat connection details

Dimensions in inches (mm)

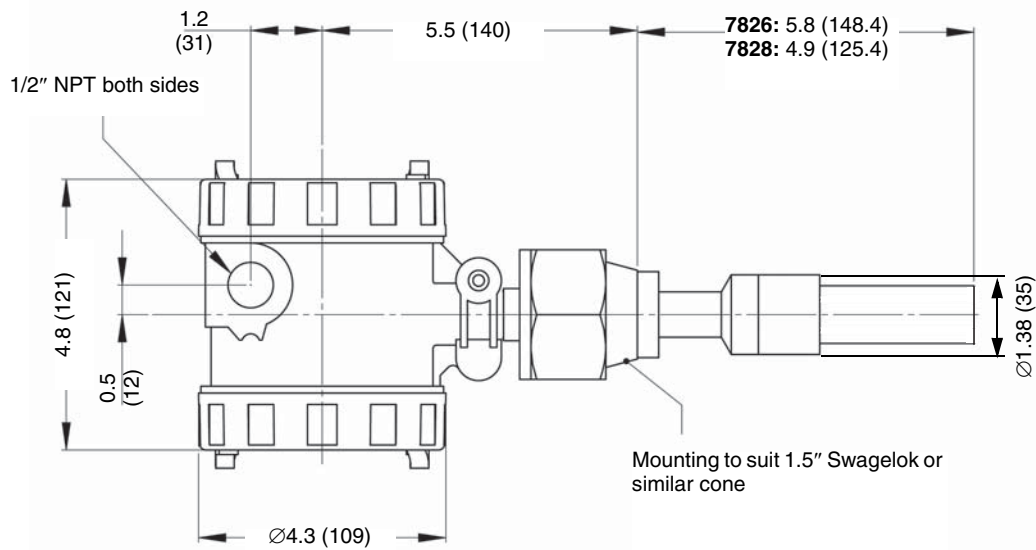

Flange connection details

Dimensions in inches (mm)

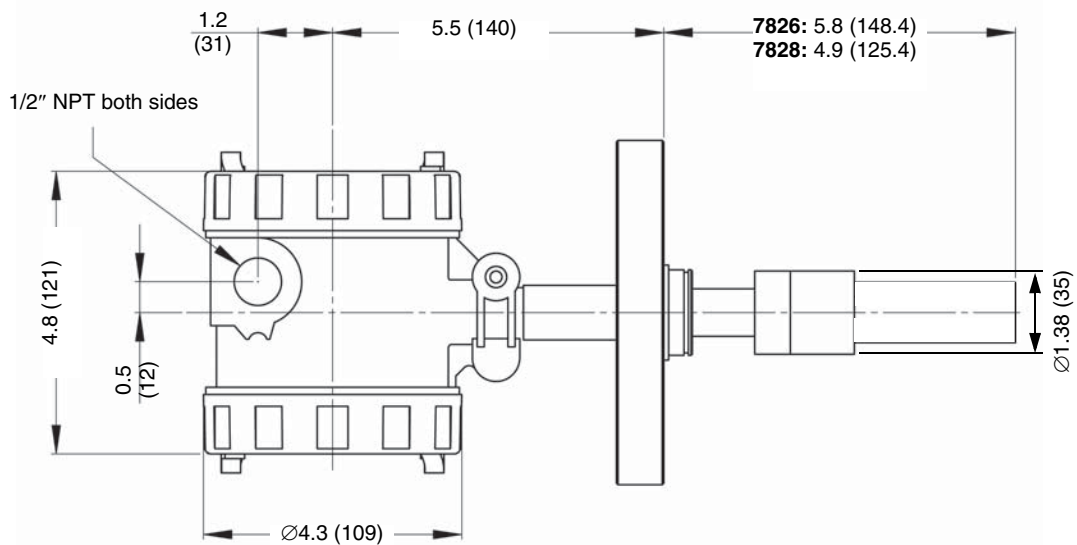

7826/7828 long stem

Open-tank connection (cast housing)

Dimensions in inches (mm)

Mounting hardware is customer specific, and is not supplied.

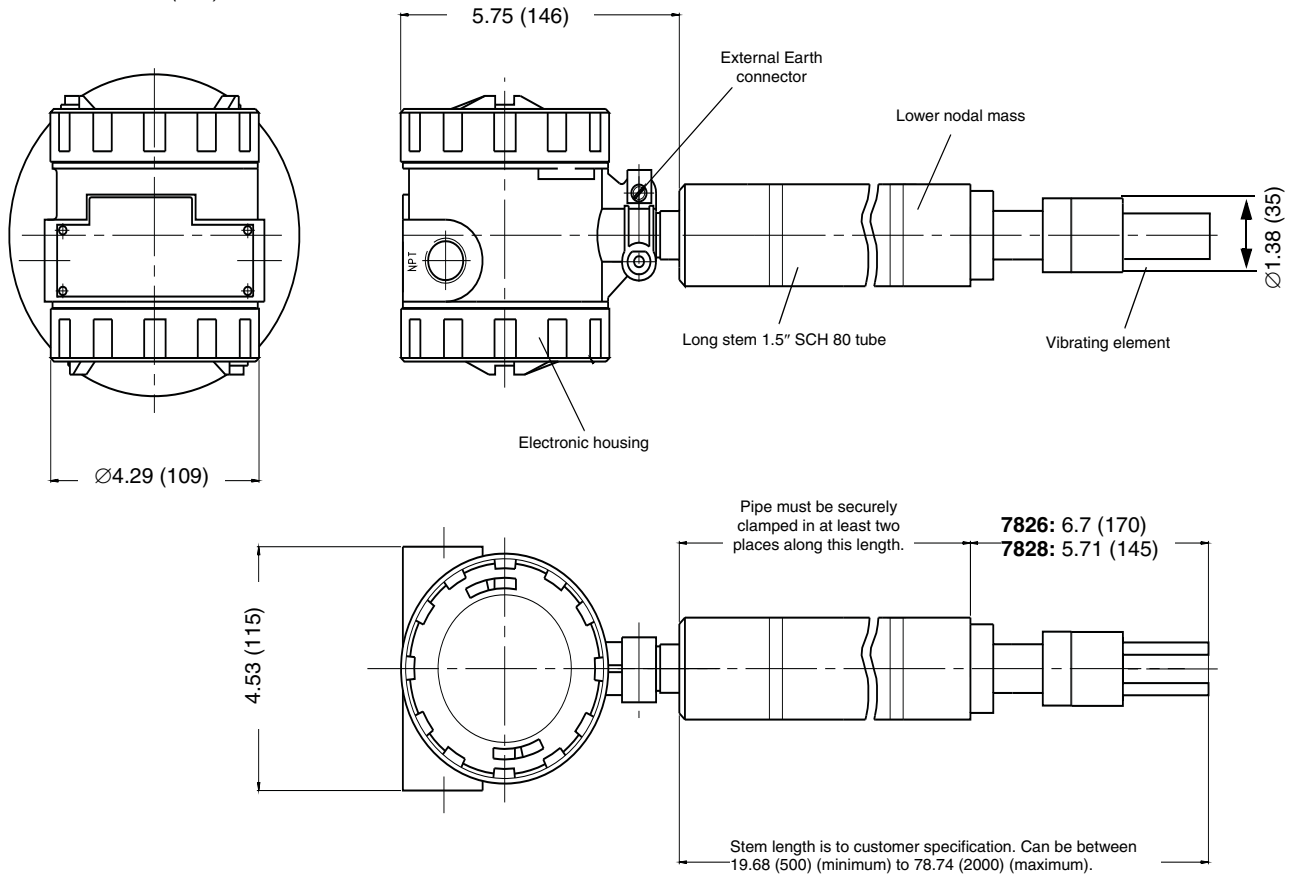

Open-tank connection (stainless steel housing)

Dimensions in inches (mm)

Mounting hardware is customer specific, and is not supplied.

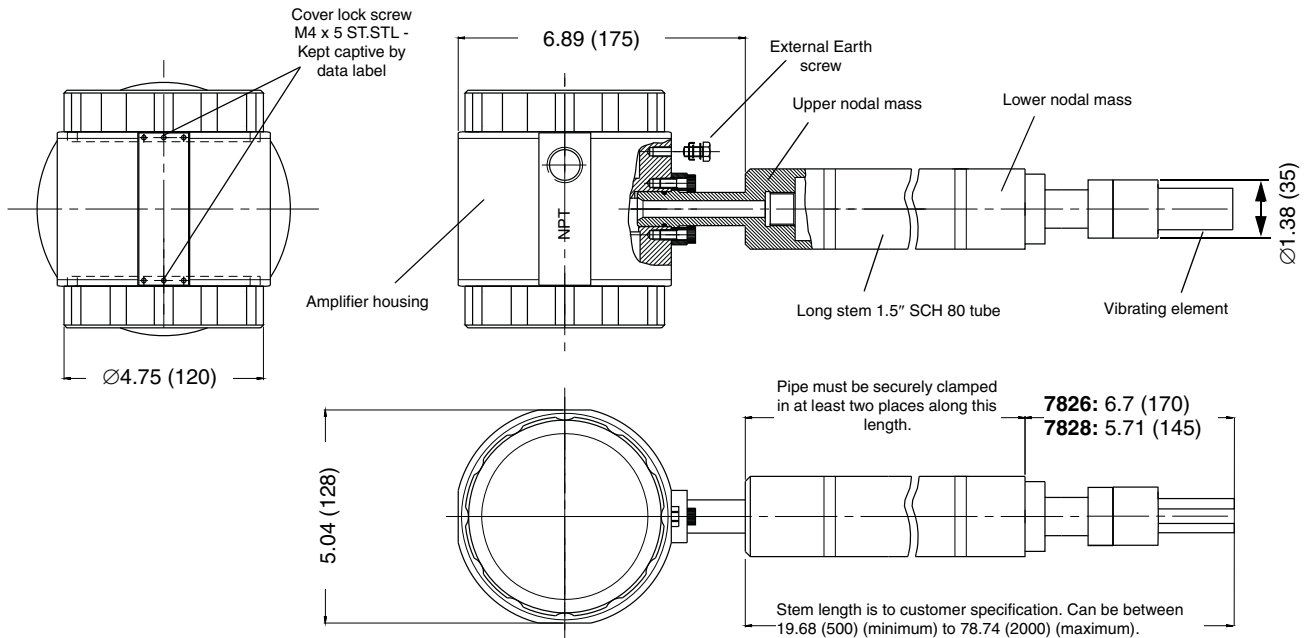

7826/7828 long stem *continued*

Closed-tank connection (cast housing)

Dimensions in inches (mm)

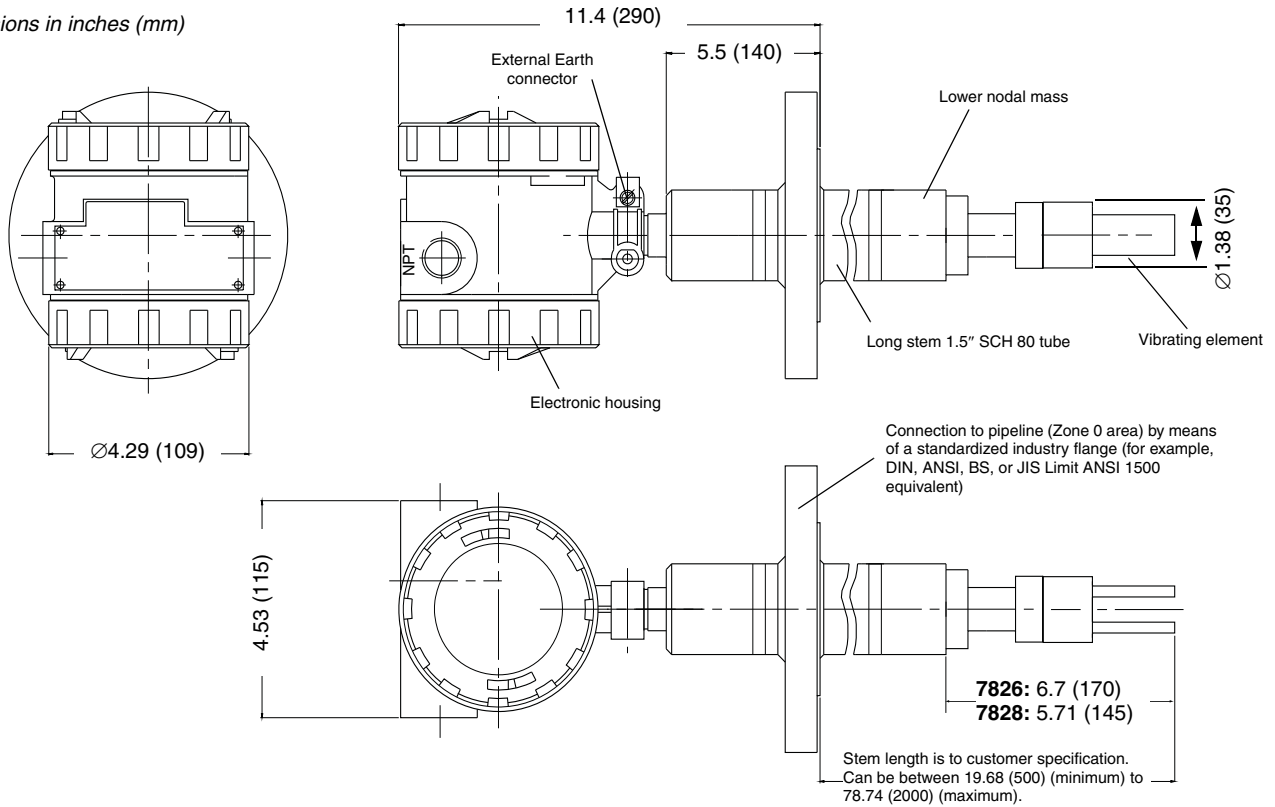

Closed-tank connection (stainless steel housing)

Dimensions in inches (mm)

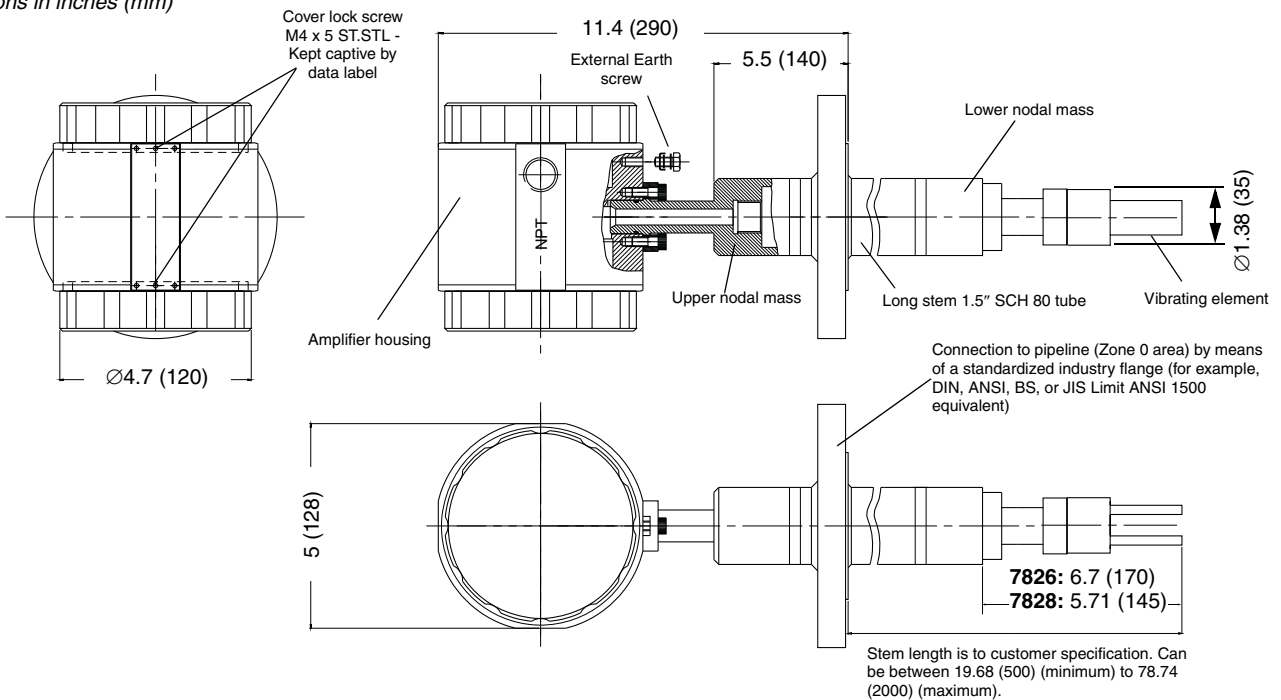

Installation

7826/7828 short stem

A variety of installation accessories, can be provided, such as weldolets, for direct pipeline insertion or flow-through chambers, which provide the optimum environment for the short-stemmed 7826 and 7828.

7826/7828 long stem

Open-tank installation example

For open-tank installations, the long-stemmed 7826/7828 is clamped to a structure.

The position of the clamp determines the insertion depth.

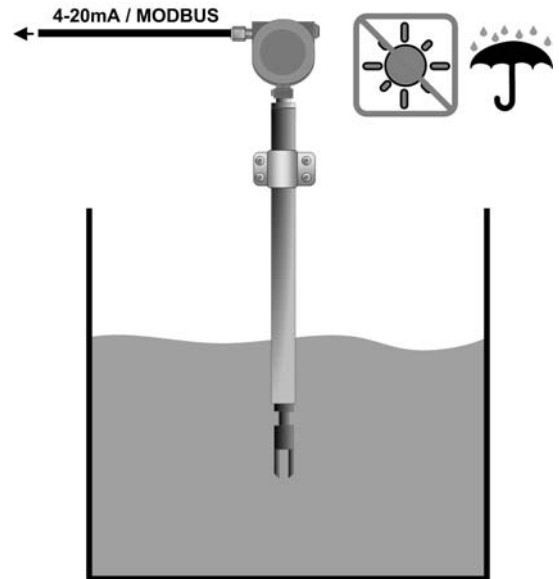

Closed-tank installation example

For closed-tank installations, the long-stemmed 7826/7828 needs a factory fitted flange attachment.

To vary the insertion depth, a standoff section with flange (not supplied) can then be used.

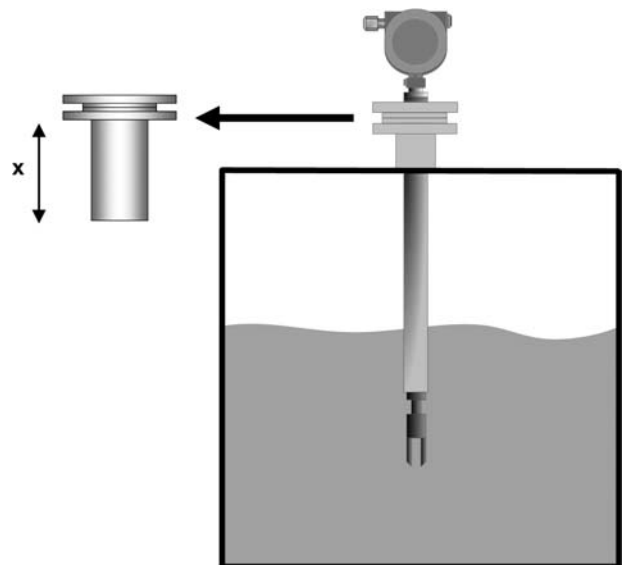

7826 Ordering information

Model	Product description
7826	7826 insertion density and concentration meter
Code	Material of wetted parts
Available with all stem length codes:	
A	316 Stainless steel, standard finish
C	316 Stainless steel, electro-polished finish
F	316 Stainless steel, PFA laminated tines
Z	ETO material
Available only with stem length codes A or Z:	
V	304 Stainless steel, standard finish
T ⁽¹⁾	Titanium, standard finish
U	Alloy B3, standard finish
E	Alloy C22, standard finish
D	Alloy C22, electro-polished finish
G	Alloy C22, PFA laminated tines
H ⁽²⁾	Alloy 400, standard finish
Available only with amplifier system codes C or D:	
N ⁽²⁾⁽³⁾	Zirconium, standard finish
Code	Amplifier system
Available only with stem length codes A or Z:	
A	Frequency output, ATEX Flame Proof / Explosion Proof
B	Frequency output, CSA (US and Canada) Explosion Proof
C	Advanced: 4–20 mA output (two 4–20 mA outputs), ATEX Flame Proof / Explosion Proof
D	Advanced: 4–20 mA output (two 4–20 mA outputs), CSA (US and Canada) Explosion Proof
Available for stem length codes C, D, E, F, G, or Z:	
G	Frequency output, non-hazardous (safe) area only
H	Frequency output, ATEX Flame Proof / Explosion Proof
J	Frequency output, CSA (US and Canada) Explosion Proof
W	Advanced: 4–20 mA output (two 4–20 mA outputs), non-hazardous (safe) area only
K	Advanced: 4–20 mA output (two 4–20 mA outputs), ATEX Flame Proof / Explosion Proof
L	Advanced: 4–20 mA output (two 4–20 mA outputs), CSA (US and Canada) Explosion Proof
Code	Amplifier enclosure
Available with all stem length codes:	
A	Aluminium alloy
Available only with stem length codes C, D, E, F, G, or Z:	
C	Stainless steel

Continued on next page

(1) Available with amplifier systems B and D only.

(2) Available with amplifier systems C and D only.

(3) Zirconium process connection options are A, B, G, R and Z only.

7826 Ordering information *continued*

Code Process connections	
Available with all stem length codes:	
A	2" ANSI CL150 raised-face (RF) flange
B	2" ANSI CL300 raised-face (RF) flange
C	2" ANSI CL600 raised-face (RF) flange
G	DN50/PN40 DIN 2527
H	DN50/PN100 DIN 2527
R	DN50/PN16 DIN 2527
Z	ETO process connection
Available only with stem length codes A or Z:	
D	2" ANSI CL900 raised-face (RF) flange
F	2" ANSI CL1500 raised-face (RF) flange
K ⁽¹⁾	3" sanitary fitting (Tri-clamp compatible)
N	1.5" Cone seat compression fitting
Available only with stem length codes C, D, E, F, G, or Z:	
T	No connectors (for open tanks), non-hazardous (safe area) only
Code Stem length	
A	0 mm: no stem extension and with standard spigot
C	20" (500 mm) with removable transit cover
D	30" (750 mm) with removable transit cover
E	40" (1000 mm) with removable transit cover
F	59" (1500 mm) with removable transit cover
G	79" (2000 mm) with removable transit cover
Z	ETO stem length ⁽²⁾
Code Default software configuration of 4–20 mA output 1 ⁽³⁾	
Available only with amplifier system codes C, D, W, K, or L:	
A	API Degrees (Americas)
B	Base density to API tables (metric configuration)
C	Line density only
D	General process including unconfigured matrix
Z	ETO software configuration (customer data required)
Available only with amplifier system codes A, B, G, H, or J:	
T	No software configuration – frequency output only
Code Calibration range	
L	Density at 20 °C (68 °F)
Z	ETO calibration range
<i>Continued on next page</i>	

(1) Available with calibration option A or G only.

(2) Stem lengths up to 13 ft (4 m) are available as an ETO purchase.

(3) The mA output 2 default setting is temperature.

7826 Ordering information *continued*

Code	Calibration type
Available with all stem length codes:	
A	Free stream
Z	ETO calibration type
Available only with stem length codes A or Z:	
B	2" schedule 40 boundary
D	2" schedule 80 boundary
E	3" schedule 80 boundary
G ⁽¹⁾	3" Hygienic
Code	Future option 1
B	Reserved for future use
Code	Traceability
A	None
X	Certificates of material traceability (per single order)
Typical model number: 7826AAAAATLABA	

(1) Available with process connection option K only.

7828 Ordering information

Model	Product description
7828	7828 insertion density meter
Code	Materials of wetted parts
Available with all stem length codes:	
A	316 Stainless steel, standard finish
C	316 Stainless steel, electro-polished finish
F	316 Stainless steel, PFA laminated tines
Z	ETO material
Available only with stem length codes A or Z:	
V	304 Stainless steel, standard finish
T ⁽¹⁾	Titanium, standard finish
U	Alloy B3, standard finish
E	Alloy C22, standard finish
D	Alloy C22, electro-polished
G	Alloy C22, PFA laminated tines
H	Alloy 400, standard finish
<i>Continued on next page</i>	

(1) Available with amplifier system option D only.

7828 Ordering information *continued*

Code	Amplifier system
Available only with stem length codes A or Z:	
C	Advanced: 4–20 mA output (two 4–20 mA outputs), ATEX Flame Proof / Explosion Proof
D	Advanced: 4–20 mA output (two 4–20 mA outputs), CSA (US and Canada) Explosion Proof
Available only with stem length codes C, D, E, F, G, or Z:	
W	Advanced 4–20 mA output (two 4–20 mA outputs), non-hazardous (safe) area only
K	Advanced 4–20 mA output (two 4–20 mA outputs), ATEX Flame Proof / Explosion Proof
L	Advanced 4–20 mA output (two 4–20 mA outputs), CSA (US and Canada) Explosion Proof
Code	Amplifier enclosure
Available with all stem length codes:	
A	Aluminium alloy
Available only with stem length codes C, D, E, F, G, or Z:	
C	Stainless steel
Code	Process connections
Available with all stem length codes:	
A	2" ANSI CL150 raised-face (RF) flange
B	2" ANSI CL300 raised-face (RF) flange
C	2" ANSI CL600 raised-face (RF) flange
G	DN50/PN40 DIN 2527
H	DN50/PN100 DIN 2527
R	DN50/PN16 DIN 2527
Z	ETO process connection
Available only with stem length codes A or Z:	
D	2" ANSI CL900 raised-face (RF) flange
F	2" ANSI CL1500 raised-face (RF) flange
K ⁽¹⁾	3" sanitary fitting (Tri-clamp compatible)
N	1.5" Cone seat compression fitting
Available only with stem length codes C, D, E, F, G, or Z:	
T	No connectors (for open tanks), non-hazardous (safe area) only
Code	Stem length
A	0 mm: no stem extension and with standard spigot
C	20" (500 mm) with removable transit cover
D	30" (750 mm) with removable transit cover
E	40" (1000 mm) with removable transit cover
F	59" (1500 mm) with removable transit cover
G	79" (2000 mm) with removable transit cover
Z	ETO stem length ⁽²⁾
Code	Default software configuration of 4–20 mA output 1 ⁽³⁾
A	API Degrees (Americas)
B	Base density to API tables (metric configuration)
C	Line density only
D	General process including matrix (user data required)
Z	ETO software configuration (customer data required)
<i>Continued on next page</i>	

(1) Available with calibration options A and G only.

(2) Stem lengths up to 13 ft (4 m) are available as an ETO purchase.

(3) The mA output 2 default setting is temperature.

7828 Ordering information *continued*

Code	Calibration range
L	Density at 20 °C (68 °F)
Z	ETO calibration range
Code	Calibration type
Available with all stem length codes:	
A	Free stream
Z	ETO calibration type
Available only with stem length codes A or Z:	
B	2" schedule 40 boundary
C	3" schedule 40 boundary
D	2" schedule 80 boundary
E	3" schedule 80 boundary
G ⁽¹⁾	3" Hygienic
Code	Future option 1
B	Reserved for future use
Code	Traceability
A	None
X	Certificates of material traceability (per single order)
Typical model number: 7828ACAAAALABA	

(1) Available with process connection option K only.

Micro Motion—The undisputed leader in flow and density measurement



World-leading Micro Motion measurement solutions from Emerson Process Management deliver what you need most:

Technology leadership

Micro Motion introduced the first reliable Coriolis meter in 1977. Since that time, our ongoing product development has enabled us to provide the highest performing measurement devices available.

Product breadth

From compact, drainable process control to high flow rate fiscal transfer—look no further than Micro Motion for the widest range of measurement solutions.

Unparalleled value

Benefit from expert phone, field, and application service and support made possible by more than 750,000 meters installed worldwide and over 30 years of flow and density measurement experience.

 www.micromotion.com

© 2013 Micro Motion, Inc. All rights reserved. The Emerson logo is a trademark and service mark of Emerson Electric Co. Micro Motion, ELITE, ProLink, MVD and MVD Direct Connect marks are marks of one of the Emerson Process Management family of companies. All other marks are property of their respective owners.

Micro Motion supplies this publication for informational purposes only. While every effort has been made to ensure accuracy, this publication is not intended to make performance claims or process recommendations. Micro Motion does not warrant, guarantee, or assume any legal liability for the accuracy, completeness, timeliness, reliability, or usefulness of any information, product, or process described herein. We reserve the right to modify or improve the designs or specifications of our products at any time without notice. For actual product information and recommendations, please contact your local Micro Motion representative.

Emerson Process Management Micro Motion Americas

Worldwide Headquarters
7070 Winchester Circle
Boulder, Colorado USA 80301
T: 800 522 6277
T: +1 (303) 527 5200
F: +1 (303) 530 8459
Mexico T: 52 55 5809 5300
Argentina T: 54 11 4837 7000
Brazil T: 55 15 3238 3527
Venezuela T: 58 26 1792 1858

Emerson Process Management Micro Motion Europe/Middle East

Central & Eastern Europe T: +41 41 7686 111
Dubai T: +971 4 811 8100
France T: 0800 917 901
Germany T: 0800 182 5347
Italy T: 8008 77334
The Netherlands T: (31) 318 495 555
Belgium T: +32 (0) 2 716 77 11
Spain T: +34 913 586 000
U.K. T: 0870 240 1978
Russia/CIS T: +7 495 981 9811

Emerson Process Management Micro Motion Asia Pacific

Australia T: (61) 3 9721 0200
China T: (86) 21 2892 9000
India T: (91) 22 6662 0566
Japan T: (81) 3 5769 6803
South Korea T: (82) 2 3438 4600
Singapore T: (65) 6 777 8211

For a complete list of contact information and websites, please visit: www.emersonprocess.com/home/contacts/global.

