

3a

**INDUSTRIAL PRESSURE SWITCHES
Type A**

- Heavy duty switch for virtually any industrial application involving air, water, steam or oil
- Bellows, piston and diaphragm actuated types
- Settings externally adjustable by screwdriver or accessory plastic knob
- Gasketed die cast enclosure – oil, coolant and moisture tight to IP65
- Mechanism incorporates hardened parts and short travel characteristics for long mechanical life under severe conditions
- Double break snap switch with silver contacts, single or double pole
- Fully user serviceable

Bellows Actuated Pressure Switches Type ACW	3a2
Piston Actuated Pressure Switches Type ADW	3a3
Differential Pressure Switches Type AEW	3a4
Pressure Switch selection guide	3a5
Accessories	3a6
Replacement Parts	3a6
Modification Kits	3a6
Technical Data	3a7 – 3a8
Dimensions	3a9 – 3a10

Bellows Actuated Pressure Switches

For use on Air, Oil, Water, other liquids and Gases. Ingress Protection IP65 □ (IEC 144)

Type ACW Bellows actuated pressure switches



Single pole – double throw contacts (1NO+1NC)

Range setting		Adjustable Differential		Maximum allowable pressure		Order Class 9012
Switch can be adjusted to operate on Falling pressure within this range		Add to range setting to obtain operating point on Rising pressure				
Bars	PSI	Bars	PSI	Bars	PSI	Type...
0.1– 0.7	1–10	0.04– 0.3	½–5	2	30	ACW-3
0.1– 1.3	1–20	0.07– 0.4	1–6	2	30	ACW-4
0.1– 5.1	1–75	0.3 – 1	4–15	7	100	#ACW-5
0.1– 7.5	1–110	0.5 – 2	7–30	17	255	●ACW-1
1.4– 12	20–180	0.7 – 2	10–30	17	255	●ACW-8
0.7– 18	10–265	1.1 – 1.7	15–25	20	300	ACW-9
0.7– 20	10–300	1.7 – 8.6	25–125	41	600	ACW-2
5.2– 34	75–500	3.5 – 8	50–120	137	2000	ACW-6
10.4– 69	150–1000	5.9 –10	85–145	137	2000	ACW-7
24.1–131	350–1900	11 –20	150–300	172	2500	ACW-10

Replacement Snap Switch assembly – Class 9007 Type AO-1



Double pole – double throw contacts (2NO+2NC)

Range setting		Adjustable Differential		Maximum allowable pressure		Order Class 9012
Switch can be adjusted to operate on Falling pressure within this range		Add to range setting to obtain operating point on Rising pressure				
Bars	PSI	Bars	PSI	Bars	PSI	Type...
0.1– 0.7	1–10	0.06– 0.4	¾–7	2	30	ACW-23
0.1– 1.3	1–20	0.14– 0.7	2–10	2	30	ACW-24
0.1– 5.1	1–75	0.5 – 1.3	6–20	7	100	ACW-25
0.1– 7.5	1–110	0.9 – 2.7	13–40	17	255	ACW-21
1.4– 12	20–180	1.1 – 2.7	15–40	17	255	ACW-28
0.7– 17	10–250	1.6 – 2.4	23–35	20	300	ACW-29
0.7– 20	10–300	2.5 –10.3	35–150	41	600	ACW-22
5.2– 34	75–500	5.9 –11	85–160	137	2000	ACW-26
10.4– 69	150–1000	9.3 –13	135–200	137	2000	ACW-27
24.1–131	350–1900	16.6 –24	240–350	172	2500	ACW-20

Replacement Snap Switch assembly – Class 9007 Type CO-3

Connection data

Pressure connection: G¼" to BS2779
 Conduit (Electrical) entry: Form M11 (standard), 20mm Iso metric
 Form M12, PG13.5 DIN 40430
 Note: NPT Threads available to special order

On Form H3 devices, the minimum adjustable differential is 1½ times that quoted, except on types ACW 6, 7 & 10 where minimum differential is twice the quoted figure.

Spare Parts Page 3a6
Accessories Page 3a6
Technical Data Pages 3a7 and 3a8
Dimensions Page 3a9

Ordering Instructions
 State... **Class, Type** and **Form No.**
 (where applicable, see page 3a6)
 Eg: Class **9012** Type **ACW-3** Form **P2**

- When fitted with suitable cable gland or adequately sealed conduit entry
- # Tested to BS 6134 1981
- Registered with the Loss Prevention Council as suitable for use in sprinkler systems.

High Pressure Hydraulic Switches

For use on Oil or Hydraulic Fluids only. Ingress Protection IP65 □ (IEC 144)

Type ADW High Pressure Piston Actuated Pressure Switches



Single pole – double throw contacts (1NO+1NC)

Range setting		Adjustable Differential		Maximum allowable pressure		Order Class 9012
Limits of Pressure between which switch can be adjusted to operate on Rising pressure		Subtract from range setting to obtain operating point on Falling pressure				Type...
Bars	PSI	Bars	PSI	Bars	PSI	
9.3– 68.9	135–1000	2.4– 9.3	35–135	689	10,000	ADW-3
27.6–206.7	400–3000	6.9–27.6	100–400	689	10,000	ADW-4
37.9–344.5	550–5000	8.6–27.6	150–400	689	10,000	ADW-7

With piston seal *

Bars	PSI		Bars	PSI	Type...
9.3– 68.9	135–1000	Increases with range See Table below	689	10,000	#ADW-5
27.6–206.7	400–3000		689	10,000	ADW-6

Double pole – double throw contacts (2NO+2NC)

Range setting		Adjustable Differential		Maximum allowable pressure		Order Class 9012
Limits of Pressure between which switch can be adjusted to operate on Rising pressure		Subtract from range setting to obtain operating point on Falling pressure				Type...
Bars	PSI	Bars	PSI	Bars	PSI	
9.3– 68.9	135–1000	3.1–13.8	45–200	689	10,000	ADW-23
27.6–206.7	400–3000	8.6–34.5	125–500	689	10,000	ADW-24
37.9–344.5	550–5000	13.8–41.3	200–600	689	10,000	ADW-27

With piston seal *

Bars	PSI		Bars	PSI	Type...
9.3– 68.9	135–1000	Increases with range See Table below	689	10,000	ADW-25
27.6–206.7	400–3000		689	10,000	ADW-26

Approximate differentials for types ADW-5, 6, 25, 26

Bars		ADW-5		ADW-25		PSI		ADW-5		ADW-25	
		Min	Max	Min	Max			Min	Max	Min	Max
Overall Range	9.3–68.9					Overall Range	135–1000				
Lower End	9.3–29.3	4.8	6.9	6.2	7.9	Lower End	135– 425	70	100	90	115
Middle	29.3–49.3	6.5	9.3	8.3	11.0	Middle	425– 715	95	135	120	160
Upper End	49.3–68.9	8.6	10.3	10.3	12.4	Upper End	715–1000	125	150	150	180
Type		ADW-6		ADW-26		Type		ADW-6		ADW-26	
		Min	Max	Min	Max			Min	Max	Min	Max
Overall Range	27.6–206.7					Overall Range	400–3000				
Lower End	27.6– 87.2	14.5	20.7	17.2	24.1	Lower End	400–1265	210	300	250	350
Middle	87.2–146.8	21.4	28.2	25.5	33.8	Middle	1265–2130	310	410	370	490
Upper End	146.8–206.7	27.6	34.5	34.5	38.6	Upper End	2130–3000	400	500	500	560

Connection data

Pressure connection: G $\frac{3}{8}$ " to BS2779
 Conduit (Electrical) entry: Form M11 (standard) 20mm Iso Metric
 Form M12 PG13.5 DIN 40430
 Note: NPT Threads available to special order.

Spare Parts Page 3a6
 Accessories Page 3a6
 Technical Data Pages 3a7 and 3a8
 Dimensions Page 3a9

Standard controls should not be used with phosphate base synthetic hydraulic fluids. Refer to Technical Data.

Ordering Instructions

State... **Class Type** and **Form No.**
 (where applicable, see page 3a6)
 Eg: Class **9012** Type **ADW-5**

* Prevents oil leakage – refer to Technical Data
 # Tested to BS 6134 1981
 □ When fitted with suitable Cable Gland or adequately sealed conduit entry

3a

Differential Pressure Switches

Ingress Protection IP65 □ (IEC 144)

Type AEW Bellows actuated differential pressure switches

Single pole – double throw contacts (1NO+1NC)



Working Pressure Range ('Y' must always be greater than 'X')		Maximum Allowable Pressure		* Sensitivity Between Opening and Closing of Contacts		Adjustable Pressure Differential ●		Order Class 9012
Bars	PSI	Bars	PSI	Bars	PSI	Bars	PSI	Type...

For use on Air, Water or Oil (Bellows Actuated)

0-6.89 0-13.78	0-100 0-200	6.89 17.57	100 255	0.28-0.96 0.55-1.38	4-14 8-20	0.03-1.38 0.2-2.76	0.5-20 3-40	AEW-5 ●AEW-1
760 mm Hg Vac 1.38 to 20		2.07 30		25-406 mm Hg 0.03-0.55 or 1/2- 8		0-406 mm Hg 0.02-0.55 or 0.25- 8		AEW-3

Replacement snap switch assembly – Class 9007 Type AO-1

Application

Differential pressure switches are used to control, or respond to a change in, the difference between two pressures. On these devices the top bellows, identified as the "X" or lower pressure side, works in opposition to the bottom bellows, identified as the "Y" or higher pressure side. These devices can control lower pressure X to maintain a constant difference from variable pressure Y or can control higher pressure Y to maintain a constant difference from variable pressure X or can initiate an alarm circuit to indicate that a predetermined pressure difference has widened beyond or narrowed below the desired value or can be made to operate when a predetermined pressure difference has been reached as a result of either a widening or a narrowing difference between pressures.

Application Example for Differential Pressure Switch using AEW-1

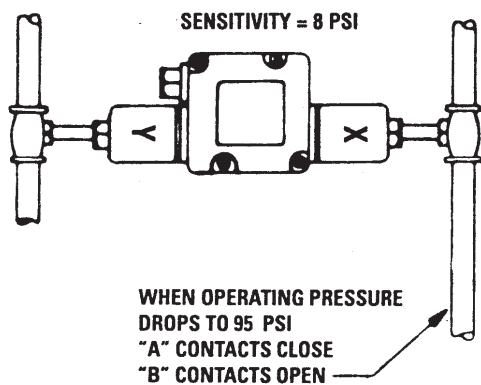

NOTE - THE LOWEST SUPPLY PRESSURE AT WHICH THE SWITCH WILL CYCLE IS EQUAL TO THE SUM OF THE PRESSURE DIFFERENCE AND THE SENSITIVITY FOR WHICH THE DEVICE IS ADJUSTED. IN THIS EXAMPLE, THIS EQUALS 25 PSI. BELOW THIS VALUE, CONTACT "A" REMAINS OPEN, "B" REMAINS CLOSED.

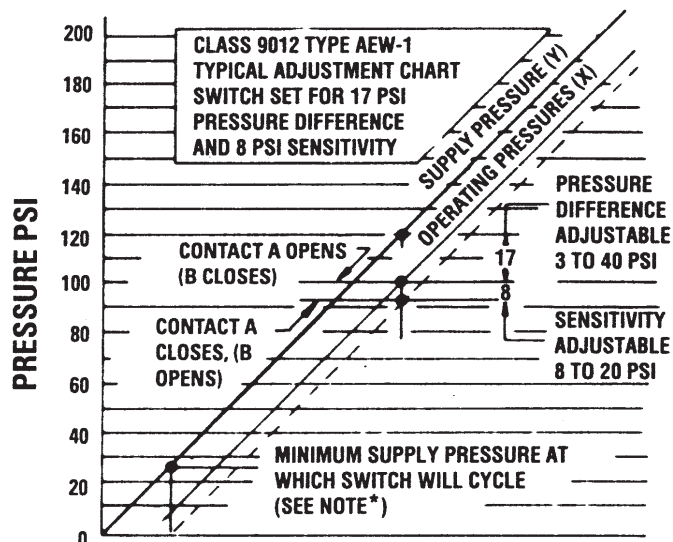

PRESSURE/CONTACT STATE RELATIONSHIP

Connection data
Pressure connection: G1/4" BS2779. x2.
Conduit (Electrical) entry: Form M11 standard 20mm Iso Metric.

Technical Data Pages 3a7 and 3a8
Dimensions Page 3a10

● Registered with the Loss Prevention Council as suitable for use in sprinkler systems.

Ordering Instructions
State... **Class and Type**
Eg: Class 9012 Type AEW-1

* Adds to adjustable pressure differential to obtain operating point on a widening pressure difference.
□ When fitted with suitable cable gland or adequately sealed conduit entry
● Switch can be adjusted to operate on a narrowing pressure difference within this range.

Pressure Switch Selection Criteria

PRESSURE SWITCH SELECTION GUIDE

The selection of a Pressure Switch for a particular application is straightforward with Square D products.

Selection criteria are typically as follows:

ENVIRONMENT – This will affect the degree of ingress protection needed, and possibly the temperature characteristics. All Square D Type A devices meet IP65 and may be used in ambient temperatures from -56°C to $+85^{\circ}\text{C}$, with a maximum media temperature of 125°C .

THE PRESSURE MEDIA – This may be crucial as certain media used over a long term may damage parts of the mechanism with which they come into contact. Square D Pressure Switches are suitable for use on a wide variety of media. Contact Telemecanique for further information.

DIMENSIONS – Square D Type A devices are compact two point switching types.

MAXIMUM NORMAL SYSTEM PRESSURE – This will determine the range of the device selected. Square D switches are available for system pressures up to 9000 psi.

MAXIMUM SURGE PRESSURE EXPECTED – This will affect selection as a device must be capable of accepting the maximum surge expected. Square D Pressure switches are highly tolerant of system surges.

SWITCHING POINTS REQUIRED – On both rising and falling pressure.

DIFFERENTIAL REQUIRED – The difference between the rising and falling pressure switching points

CONNECTION – All Square D devices have standard G Pressure connections to BS2779 and 20mm Iso Metric conduit entries. (PG and NPT entries available to order).

MECHANICAL LIFE – Crucial in fast cycling applications. Square D Type A devices are built for long mechanical life and all parts subject to wear are serviceable.

ELECTRICAL CHARACTERISTICS – Rating and number of contacts – Square D Type A devices are available with single or double pole changeover contacts.

3a

Accessories, Replacement Parts and Modifications

For use with	Description	Class	Order Type...
Replacement Parts Kits for Types ACW & ADW Pressure Switches			
ACW Series B	Bellows kit for Types ACW1, 21, 8 and 28	9998	PCM-25
ACW Series B	Bellows kit for Types ACW2 and 22	9998	PCM-26
ACW Series B	Bellows kit for Types ACW3, 23, 4 and 24	9998	PCM-27
ACW Series B	Bellows kit for Types ACW5 and 25	9998	PCM-28
ACW Series B	Bellows kit for Types ACW9 and 29	9998	PCM-29
ACW Series A	Bellows kit for Types ACW6, 7, 10, 26, 27 and 20	9998	PCM-50
ACW and ADW all	Gasket kit	9998	E1538-S959-G1
ACW and ADW all	Snap switch single pole double throw	9007	AO-1
ACW and ADW all	Snap switch double pole double throw	9007	CO-3
ADW	Piston and cylinder kit for Types ADW3 and 23	9998	E1538-S968-G1
ADW	Piston and cylinder kit for Types ADW4, 24, 7 and 27	9998	E1538-S969-G1
ADW	Piston and cylinder kit for Types ADW5 and 25	9998	E1538-S970-G1
ADW	Piston and cylinder kit for Types ADW6 and 26	9998	E1538-S971-G1
ADW	Diaphragm assembly kit	9998	E1538-S965-G1
ACW and ADW	Replacement lamp unit 24V/125V/250V (specify voltage)	9998	PC 185
Accessories			
ACW and ADW	Range adjustment knob	9049	A-11
ACW and ADW	Sealing cap (to prevent tampering with range adjustment)	9049	A-17
ACW and ADW	Pilot light kit 24V	9998	PC276
ACW and ADW	Pilot light kit 125V	9998	PC278
ACW and ADW	Pilot light kit 250V	9998	PC279
Factory Modifications			
ACW	Range adjustment locking nut (prevents tampering with range adjustment)		#Form Z4
ACW	Substitution of A0-2 snap-switch, with higher DC rating, replacing A0-1 (see note below)		● #Form H3
ACW single pole changeover devices	Hirschmann plug and socket electrical connector		#Form H18
<p># Factory modification only specify form no. after Class and Type.</p> <p>● Note that differential range of devices fitted with this modification will be as shown for double pole devices.</p>		<p>Ordering Instructions State... Class and Type Eg: Class 9049 Type A-17</p>	

Technical Data

Type ACW and AEW

Steam – Switches should not be applied directly on steam exceeding 15 p.s.i. However, with the installation of a steam capillary tubing kit, between the pressure system and the pressure switch, steam pressure up to 250 psi may be applied, providing this does not exceed the maximum allowable pressure rating of the switch, or the maximum temperature at the bellows.

Adjustments – The range setting is made by turning the stem on top of the device with a screwdriver. Removal of the front cover reveals the screwdriver differential adjustment in the upper right-hand corner of the device.

Surge and Pulsation Dampening – ACW switches are furnished with .060 pulsation plugs to prevent false operation of the switch on minor pressure surges. For surges of greater magnitude a surge reducer can be used.

Actuators – The materials in contact with the pressure medium on standard switches are as follows:

- Housing and Connector – Cadmium or Zinc Plated Steel
- Bellows – Phosphor Bronze
- Pulse Plug – Brass
- Joints – Soft Solder

Life Expectancy – Normally, the life of the ACW switching mechanism, excluding the bellows, is about 10 million operations. Bellows life can vary from a few thousand to millions of operations depending on operating pressure, bellows stroke, frequency of operation, presence of corrosive elements and pressure surges. Complete data on this subject is available from the factory. High speed cycling, or rapid pressure drop to zero on each cycle can drastically reduce the life of a bellows actuated switch.

Service Temperature Limitations

Ambient	Pressure Media
Minimum: -56°C (-70°F) Maximum +85°C (+185°F)	Minimum: -73°C (-100°F) Maximum +125°C (+257°F)

Mounting – Types ACW and AEW are mounted from the front. The two mounting holes are exposed by removal of the cover plate.

Type ADW

Use with High Flash Point Synthetic Hydraulic Fluids – When phosphate or phosphate ester base or other synthetic fluids which might damage the standard Buna N diaphragm are to be used, a Viton* diaphragm and piston seal is necessary. Select appropriate type GCWM pressure switch (Page 5b2) which has these fitted as standard.

*Viton is a registered trademark of Du Pont.

Oil Leakage – Slight oil leakage past the piston is normal on the devices that have no piston seal. A G¹/₈" BS2779 tapped drain hole in the cylinder wall on the low pressure side of the piston permits piping of the leakage oil back to the reservoir. This hole should never be plugged nor should oil return lines be connected to a high volume discharge system because back pressure on the drain side can damage the diaphragm. Devices with piston seals have no leakage, and although an oil return line is not needed, the drain hole still should never be plugged.

Surge and Pulsation Dampening – These devices have as standard a .020 orifice pulsation plug which prevents false operation on minor pressure surges. For heavier duty surge snubbing a surge reducer can be used.

Actuators – The materials in contact with the pressure medium on standard switches are as follows:

- Piston Housing – Cast Iron
 - Piston – Steel
 - Pulse Plug – Brass
 - Diaphragm – Nitrile Rubber (Buna N)
 - Seal – Nitrile Rubber (Buna N)
 - Back up Ring – P.T.F.E.
- } Piston Seal Types Only

Service Temperature Limitations

Ambient	Pressure Media
Minimum: -30°C (-22°F) Maximum +85°C (+185°F)	Minimum: -30°C (-22°F) Maximum +125°C (+257°F)

Mounting – Type ADW devices are mounted from the front. The two mounting holes are exposed by removal of the cover plate.

3a

Technical Data

Enclosure

Gasketed, die cast, drip tight and oil resistant housing to IP65 and, NEMA Type 13

Electrical

The snap switches used in Type A devices are:-
 Single Pole, Double throw – Class 9007 Type AO-1 Snap Switch
 Double Pole, Double throw – Class 9007 Type CO-3 Snap Switch

Contact Ratings

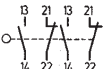
Type		AC Ratings				DC Ratings		
		120V	240V	415V	600V	120V	240V	
Single pole, double throw. One NO circuit and one NC circuit. These circuits cannot be used on opposite polarities. 	Maximum making current Inductive 35% Cos θ A	40	20	10	8	Maximum making and breaking current. Pilot duty resistive and inductive A	0.25	0.1
	Maximum breaking current Inductive 35% Cos θ A	15	10	6	5			
	Maximum continuous current A	15	15	15	15	Maximum continuous current A	15	15
	Maximum making, breaking and continuous current resistive 75% Cos θ A	15	15	15	15			
Double pole, double throw. Each pole electrically separate from the other and may be used on opposite polarities. The contacts on each pole are single pole double throw and cannot be used on opposite polarities. 	Maximum making current Inductive 35% Cos θ A	30	15	7.5	6	Maximum making and breaking current. Pilot duty resistive and inductive A	115V	230V
	Maximum breaking current Inductive 35% Cos θ A	3	1.5	0.75	0.6			
	Maximum continuous current A	10	10	10	10	Maximum continuous current A	10	10
	Maximum making, breaking and continuous current resistive 75% Cos θ A	10	10	10	10			

Adjustment

Type ACW

RANGE – Adjustment of the operating point is made externally using the screw driver adjustment located at the top of the switch. The range scale refers to the operating point on falling pressure.

DIFFERENTIAL – The differential adjusting screw is accessible by removal of the cover assembly. Turn the screw in a clockwise direction to increase the differential. This will affect only the operating point on rising pressure.

Type ADW

RANGE – This adjustment determines the operating point on rising pressure and is made externally with a screwdriver. First, the range locking nut must be loosened. After the adjustment is made, the range locking nut should be tightened.

DIFFERENTIAL – The differential adjusting screw is accessible by removal of the cover. Turn the screw in a clockwise direction to increase the differential. This will affect the resetting point on falling pressure only.

Type AEW

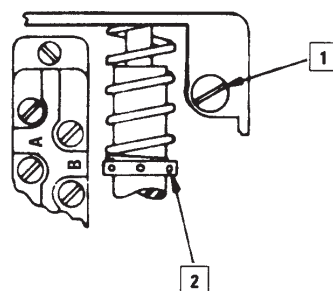

TWO ADJUSTMENTS:

- 1 SENSITIVITY
- 2 PRESSURE DIFFERENCE

PRESSURE DIFFERENCE ADJUSTING NUT. TURN TO RIGHT TO INCREASE PRESSURE DIFFERENCE

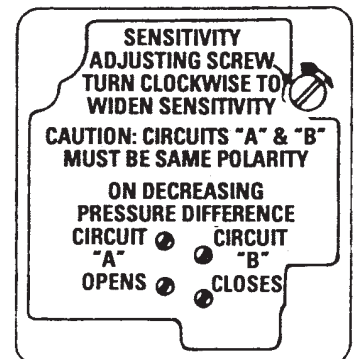

Dimensions
Type ACW and ADW

Types ACW-1, 5, 8, 9, 21, 28 & 29

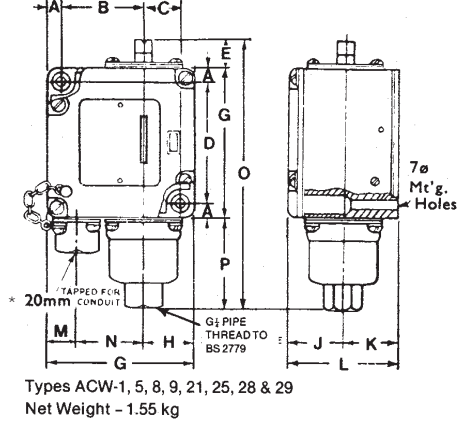

Types ACW-2, 6, 7, 10, 22, 26, 27 & 20

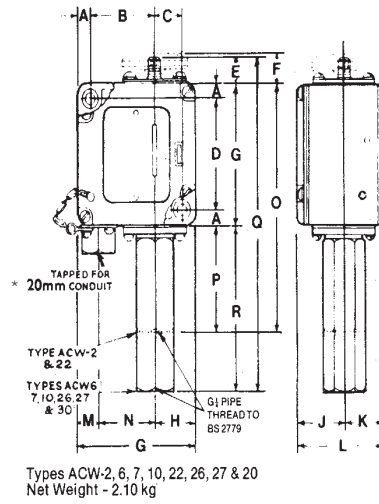

Types ACW-1, 5, 8, 9, 21, 25, 28 & 29
With Range Adjustment Sealing Cap and
Range Adjusting Knob

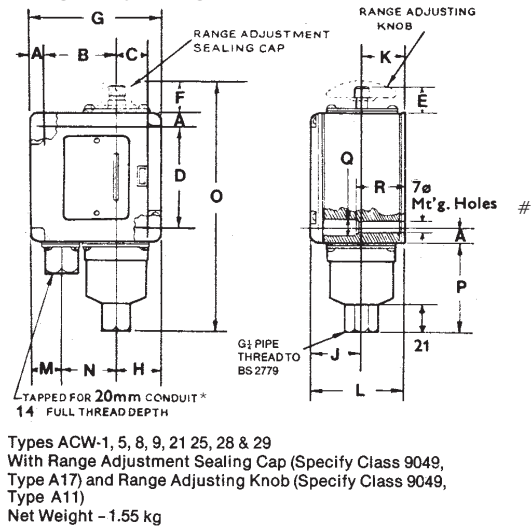

Types ACW-3, 4, 23 & 24

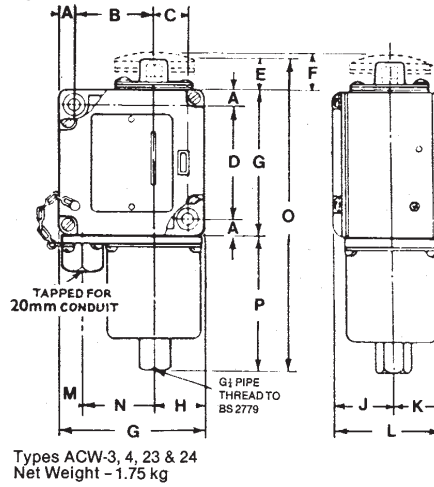

Types ADW-3, 4, 5, 6, 7, 23, 24, 25, 26 & 27

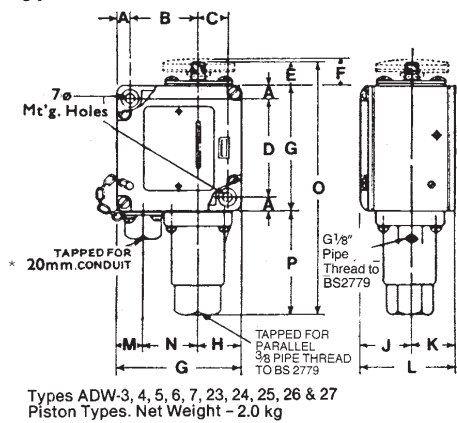

	A	B	C	D	E	F	G	H	J	K
	10	48	21	69	17	19	88	31	37	31
Type	L	M	N	O	P	Q	R			
ACW-3, 4, 23 & 24 *	68	11	46	188	83	-	-			
ACW-1, 5, 8, 9, 21, 25, 28 & 29	68	19	39	165	60	12	24			
ACW-2, 6, 7, 10, 22, 26, 27 & 30	68	18	39	173	68	221	116			
ADW-3, 4, 5, 6, 7, 23, 24, 25, 26 & 27	68	19	39	176	71	-	-			

All Dimensions in mm

*NOTE: Conduit boss now fitted to types ACW-3, ACW-4, ACW23 and ACW24 only. All other types have casings tapped 20mm ISO.
ACW-1, 5, 8, 9, 21, 25, 28 and 29 mounting hole diameter will be reduced to 6.8mm.

3a

Dimensions
Type AEW

Types AEW-1 and 5

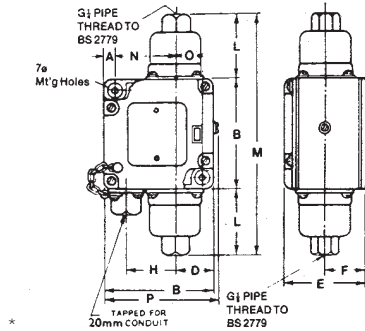

* Types AEW-1 and 5
Net Weight 1.65 kg

Type AEW-3

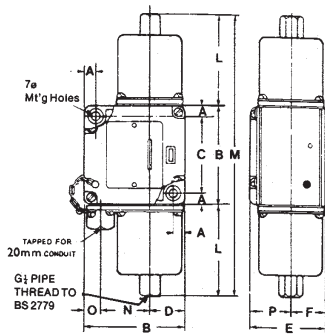

Type AEW-3
Net Weight 2.15 kg

*NOTE: Conduit boss fitted to type AEW-3 only. All other types have casings tapped 20mm ISO.

A	B	C	D	E	F	G	H	J
10	88	69	31	68	31	34	39	56
Type	K	L	M	N	O	P	Q	
AEW-3 *	-	90	263	46	11	37	-	
AEW-1 & 5	-	61	210	48	21	91	-	



3b

**INDUSTRIAL PRESSURE SWITCHES
Type G**

- General Purpose Pressure Switch
Ideal for use in machine tools and virtually any industrial application
- Adjustable or non-adjustable differential versions.
- Diaphragm or Piston actuated types
- Suitable for use on Air, Oil or Water
- 11 pressure ranges up to 621 Bars (9000 PSI)
- Low mass mechanism gives excellent performance under vibration and shock conditions
- Double break snap-switch contacts single or double pole.
- Enclosure to IP66

Diaphragm Actuated Pressure Switches with Adjustable Differential	3b2
Piston Actuated Pressure Switches with Adjustable Differential	3b2
Diaphragm Actuated Pressure Switches Non-adjustable Differential	3b3
Piston Actuated Pressure Switches Non-adjustable Differential	3b3
Vacuum Switches	3b4
Accessories	3b5
Replacement Parts	3b5
Modification Parts	3b5
Technical Data	3b6 – 3b7
Dimensions	3b8

Industrial Pressure Switches
Ingress Protection IP66 □ (IEC 144)

Type GAWM/GBWM Diaphragm Actuated Adjustable Differential Switches

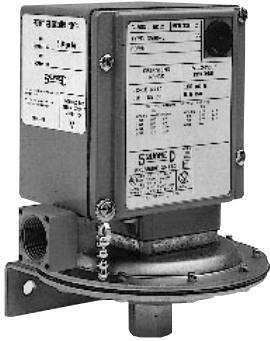

GAWM-1

Single Pole – Double Throw Contacts (1NO+1NC)

Range of Adjustment on Decreasing Pressure		Adjustable Differential Adds to set point on decreasing pressure*		Maximum allowable pressure ●		Order Class 9012
Bars	PSI	Bars	PSI	Bars	PSI	Type ...
0.014- 0.689	0.2- 10	0.021-0.137	0.3- 2	7	100	GAWM-1 #
0.07 - 2.76	1 - 40	0.137-0.551	2 - 8	7	100	GAWM-2
0.10 - 5	1.5- 75	0.2 -1.0	3 - 15	16.5	240	GAWM-4
0.20 -10	3 -150	0.4 -2.4	6 - 35	33	475	GAWM-5
0.35 -17	5 -250	0.6 -3.3	9 - 49	52	750	GAWM-6
1 -29	13 -425	1.1 -6	16 - 90	59	850	GBWM-1
1.4 -47	20 -675	1.6 -9	24 - 130	138	2000	GBWM-2

Double Pole – Double Throw Contacts (2NO+2NC)

Range of Adjustment on Decreasing Pressure		Adjustable Differential Adds to set point on decreasing pressure*		Maximum allowable pressure ●		Order Class 9012
Bars	PSI	Bars	PSI	Bars	PSI	Type ...
0.014- 0.689	0.2- 10	0.04- 0.14	0.6- 2	7	100	GAWM-21
0.07 - 2.76	1 - 40	0.2 - 0.55	3 - 8	7	100	GAWM-22
0.10 - 5	1.5- 75	0.27- 1.1	4 - 16	16.5	240	GAWM-24
0.20 -10	3 -150	0.55- 2.6	8 - 37	33	475	GAWM-25
0.35 -17	5 -250	0.8 - 1.75	12 - 49	52	750	GAWM-26
1 -29	13 -425	1.5 - 6.6	22 - 95	59	850	GBWM-21
1.4 -47	20 -675	2.3 -10	33 -140	138	2000	GBWM-22

Type GCWM Piston Actuated Adjustable Differential Switches



Single Pole – Double Throw Contacts (1NO+1NC)

Range of Adjustment on Decreasing Pressure		Adjustable Differential Adds to set point on decreasing pressure*		Maximum allowable pressure ●		Order Class 9012
Bars	PSI	Bars	PSI	Bars	PSI	Type ...
1.4- 69	20-1000	3 - 14	42- 200	690	10,000	GCWM-1
6.2-200	90-2900	8.6- 38	125- 550	1030	15,000	GCWM-2
12 -386	170-5600	21.3- 83	310-1200	1379	20,000	GCWM-3
18.6-620	270-9000	29.3-131	425-1900	1725	25,000	GCWM-4

Double Pole – Double Throw Contacts (2NO+2NC)

Range of Adjustment on Decreasing Pressure		Adjustable Differential Adds to set point on decreasing pressure*		Maximum allowable pressure ●		Order Class 9012
Bars	PSI	Bars	PSI	Bars	PSI	Type ...
1.4- 69	20-1000	4 - 15	56- 215	690	10,000	GCWM-21
6.2-200	90-2900	11.4- 40.7	165- 590	1030	15,000	GCWM-22
12 -386	170-5600	28.6- 90	415-1300	1379	20,000	GCWM-23
18.6-620	270-9000	39 -141	565-2040	1725	25,000	GCWM-24

Spares Kits Page 3b5
 Accessories and Modification Data Page 3b5
 Technical Data Pages 3b6 and 3b7
 Dimensions Page 3b8

Ordering Instructions
 State... **Class Type** and **Form No.**
 (where applicable)
 Eg: Class **9012** Type **GAWM-1** Form **P2**

Tested to BS 6134 1981
 □ When fitted with suitable cable gland or adequately sealed conduit entry.
 * Differentials listed are at maximum range. Minimum differentials will be less at lower pressures.
 For all form H3 devices differential is double the figure shown above.
 ● **Pressure Rating Warning** If the pressure switch actuators are exposed to system or surge pressures greater than the maximum allowable pressure listed, leakage from the actuator and/or a change in operating values may result.

Industrial Pressure Switches
Ingress Protection IP66 □ (IEC 144)

Type GDWM/GEWM Diaphragm Actuated Non-Adjustable Differential Switches



Single Pole – Double Throw Contacts (1NO+1NC)

Range of Adjustment on Decreasing Pressure		Approximate Switching Differential Value at Mid Range		Maximum allowable pressure ●		Order Class 9012
Bars	PSI	Bars	PSI	Bars	PSI	Type ...
0.014- 0.69	0.2- 10	0.01± .01	0.14± .1	7	100	GDWM-1
0.1 - 2.6	1 - 40	0.09±0.03	1.2 ±0.4	7	100	GDWM-2
0.1 - 5.3	1.5- 75	0.14±0.04	2 ± .5	16.5	240	GDWM-4
0.2 -10	3 -150	0.27± .055	4 ± .8	33	475	GDWM-5
0.34 -17	5 -250	0.48±0.1	7 ±1.5	52	750	GDWM-6
0.9 -29	13 -425	0.69±0.25	10 ±3.5	59	850	GEWM-1
1.4 -47	20 -675	1.2 ±0.35	18 ±5	138	2000	GEWM-2

Double Pole – Double Throw Contacts (2NO+2NC)

Range of Adjustment on Decreasing Pressure		Approximate Switching Differential Value at Mid Range		Maximum allowable pressure ●		Order Class 9012
Bars	PSI	Bars	PSI	Bars	PSI	Type ...
0.014- 0.69	0.2- 10	0.02±0.02	0.3± .2	7	100	GDWM-21
0.1 - 2.6	1 - 40	0.1 ±0.04	1.5± .5	7	100	GDWM-22
0.1 - 5.3	1.5- 75	0.21±0.1	3 ±1	16.5	240	GDWM-24
0.2 -10	3 -150	0.4 ± .11	6 ±1.5	33	475	GDWM-25
0.34 -17	5 -250	0.6 ± .14	9 ±2	52	750	GDWM-26
0.9 -29	13 -425	0.9 ± .35	13 ±5	59	850	GEWM-21
1.4 -47	20 -675	1.5 ±0.5	22 ±7	138	2000	GEWM-22

Type GFWM Piston Actuated Non-Adjustable Differential Switches



Single Pole – Double Throw Contacts (1NO+1NC)

Range of Adjustment on Decreasing Pressure		Approximate Switching Differential Value at Mid Range		Maximum allowable pressure ●		Order Class 9012
Bars	PSI	Bars	PSI	Bars	PSI	Type ...
1.4- 69	20-1000	1.8±0.6	26± 9	690	10,000	GFWM-1
6.2-200	90-2900	6.2±1	90±15	1030	15,000	GFWM-2
11.7-386	170-5600	12.4±3.8	180±55	1380	20,000	GFWM-3
18.6-621	270-9000	18.9±4.8	275±70	1725	25,000	GFWM-4

Double Pole – Double Throw Contacts (2NO+2NC)

Range of Adjustment on Decreasing Pressure		Approximate Switching Differential Value at Mid Range		Maximum allowable pressure ●		Order Class 9012
Bars	PSI	Bars	PSI	Bars	PSI	Type ...
1.4- 69	20-1000	2.4±0.8	35±12	690	10,000	GFWM-21
6.2-200	90-2900	8.3±1.4	120±20	1030	15,000	GFWM-22
11.7-386	170-5600	16.5±5	240±72	1380	20,000	GFWM-23
18.6-621	270-9000	25 ±6.4	365±93	1725	25,000	GFWM-24

Spares Kits Page 3b5
 Accessories and Modification Data Page 3b5
 Technical Data Pages 3b6 and 3b7
 Dimensions Page 3b8

Ordering Instructions
 State... **Class Type** and **Form No.**
 (where applicable)
 Eg: Class **9012** Type **GFWM-1**

● **Pressure rating warning.**
 If the pressure switch actuators are exposed to system or surge pressures greater than the maximum allowable pressure listed, leakage from the actuator and/or a change in operating values may result.
 □ When fitted with suitable cable gland or adequately sealed conduit entry.

3b

Vacuum Switches Ingress Protection IP66 □ (IEC 144)

Type GAW Diaphragm Actuated Vacuum Switches

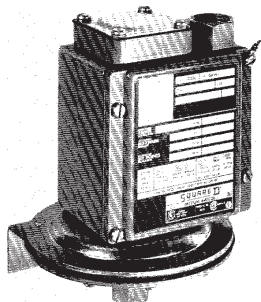

Single Pole – Double Throw Contacts (1NO+1NC)

Range (Millibars)	Differential (Millibars)	Maximum allowable Positive Pressure PSIG	Order Class 9016 Type ...
996.0	27–305*	100	GAW-1
966.0	44–312# 169–678	100	GAW-2

* At low vacuum
At high vacuum

9012 GAW

Dimensions

Type GAW 1

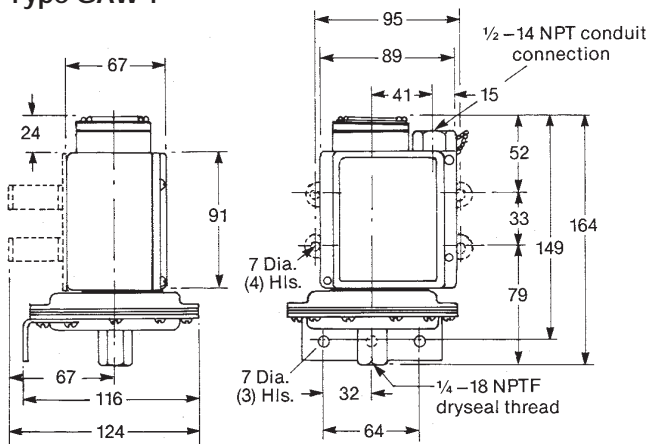

Type GAW 2

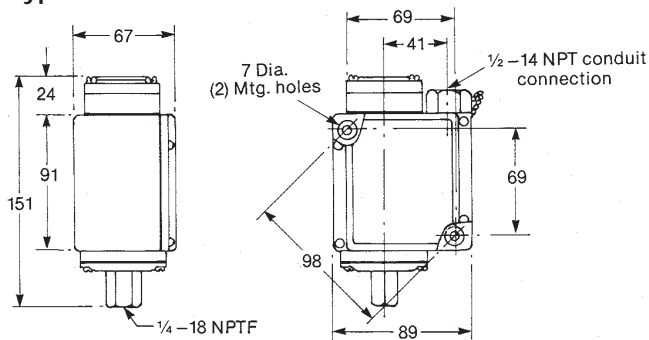

Technical Data Pages 3b6 and 3b7
Modification Data Page 3b5

Ordering Instructions
State... **Class** and **Type**
Eg: Class **9016** Type **GAW-1**

□ When fitted with suitable cable gland or adequately sealed conduit entry.

Accessories, Replacement Parts and Modification Data

For use with	Description	Order Class 9998 Type...
Replacement Parts Kit		
GAWM 1.21 GDWM 1.21	Diaphragm Assembly	PC265
GAWM 2.22 GDWM 2.22	Diaphragm Assembly	PC266
GAWM 4.24 GDWM 4.24	Diaphragm Assembly	PC267
GAWM 5.25 GDWM 5.25	Actuator Assembly	PCM268
GAWM 6.26 GDWM 6.26	Actuator Assembly	PCM269
GBWM 1.21 GEWM 1.21	Actuator Assembly	PCM177
GBWM 2.22 GEWM 2.22	Actuator Assembly	PCM178
GCWM 1.21 GFWM 1.21	Piston Assembly	PCM270
GCWM 2.22 GFWM 2.22	Piston Assembly	PCM271
GCWM 3.23 GFWM 3.23	Piston Assembly	PCM272
GCWM 4.24 GFWM 4.24	Piston Assembly	PCM273
All single pole type switches	Snap Switch Kit	PC 339
All double pole type switches	Snap Switch Kit	PC 340
All types	Gasket Kit	PC 184
All types 1-6 and 21-26	Lamp unit - 24V 125V 250V (specify voltage)	PC 185
	NOTE - Replacement lamp unit only.	
Accessories		
All types 1-6 and 21-26	Pilot Light Kit - 24V Pilot Light Kit - 125V Pilot Light - 250V	PC 276 PC 278 PC 279
Modifications #		
GAWM GDWM GAW	Omit .060 pulsation plug	Form *P2
GAWM GDWM GBWM GEWM	Ethylene propylene diaphragm and seal. Type 316 stainless steel connector and pulsation plate.	Form *Q3
GAWM GDWM GBWM GEWM	VITON● diaphragm and seal. Type 316 stainless steel connector and pulsation plate (Minimum differential increases by 100%)	Form *Q4
GCWM GFWM	Ethylene propylene diaphragm and seal. Type 440 stainless steel piston in Type 303 or 431 stainless steel housing. Steel retainer - PTFE. Pulsation plug - brass.	Form *Q5
All Types	Range Scale Window	Form V1
All Types	S.P.D.T snap switch fitted, rated 1.1 amps at 125V DC. (Note:- stated differential figures are doubled.)	Form H3
<p># Add Form No. to Switch Type No. E.g. Class 9012 Type GCWM-6 Form H3</p> <p>● Registered trade mark of Du Pont</p> <p>* If one of these form designations appears on the pressure switch nameplate, the 9998 PC number for the replacement parts kit must be completed with that same FORM designation.</p> <p>Example: 9012 GAWM-2 takes diaphragm No. 9998 PC-266 9012 GAWM-2 Form Q3 takes diaphragm No. 9998 PC-266 Form Q3.</p> <p>Ordering Instructions State... Class and Type Eg: Class 9998 Type PCM 270</p>		

3b

Technical Data

Type G Pressure Switches

Include diaphragm and piston actuated versions, available with adjustable or non-adjustable differentials.

Piston Actuated Devices

Whilst the piston operated switches are compatible with air or water, it should be noted that a small amount of lubrication is necessary in the operating media to ensure long service life from the switch. Dry operating media can reduce the service life of the device, through lack of piston seal lubrication. The extent of reduction depends greatly on frequency of operation.

Use on Steam Systems

Do not use directly on steam system in excess of 1 bar (14.5 psig). Indirect use may be accomplished by attaching a minimum of ten feet of capillary tubing between the steam source and the actuator. This permits the use of steam up to 17 Bars (245 psig) subject to the maximum allowable pressure rating and the maximum temperature rating of the switch.

Use with Incompatible Pressure Media

For applications where the pressure medium is not compatible with, or corrosive to the standard actuator, diaphragms and seals in alternative materials are available in stainless steel housings.

Enclosure

The Type G switch is housed in a die cast enclosure and fitted with nitrile rubber gaskets to comply with the requirements of BS 5420/IEC 144 degree of protection IP 66.

The switch also meets U.L. rain-tight requirements, NEMA 4 water-tight and dust-tight indoor and outdoor specifications, NEMA 13 oil-tight and dust-tight indoor specifications and C.S.A. enclosure 4 requirements.

For hazardous locations, devices in cast iron enclosures, which meet NEMA 7 and 9 specification, are available. Please contact local Field Office for details.

Actuators – Construction and Materials

The Type G switch utilises diaphragm and piston actuators which have maximum allowable ratings in excess of 200% of the adjustable range.

The materials in contact with the pressure medium on standard switches are as follows:

1. Diaphragm Actuated Devices

Types GAWM and GDWM
Housing: Steel, copper brazed, zinc plated and passivated.
Diaphragm: nitrile rubber.
Pulsation Plug: brass

Types GBWM and GEWM
Connector and Pulsation Plate: steel, zinc plated and passivated.
Diaphragm and Seal: nitrile rubber.

2. Piston Actuated Devices

Types GCWM and GFWM
Housing:
Stainless Steel, Type 303 - on Low Pressure Types 1, 2, 21, & 22.
Stainless Steel Type 431 - on High Pressure Types 3, 4, 23 & 24.
Piston: Stainless Steel Type 440
Diaphragm and Seal: Viton*
Seal Retainer: P.T.F.E.
Pulsation Plug: Stainless Steel.

Adjustments

Removal of the cover permits access to the setting adjustment and, on adjustable differential types, to the differential adjustment. Changes to both may be made with a screwdriver.

Surge and Pulsation Dampening

All Type G switches are furnished with pulsation plugs to dampen pressure surges. If further surge dampening is required, a surge reducer is recommended.

Although the diaphragm will withstand wide pressure changes on each operating cycle, the pressure applied to the diaphragm during the normal operating cycle should never exceed the maximum value listed in the "Range" column in the catalogue listing. Life will be considerably reduced if regularly cycled above this pressure.

Surges which exceed the maximum range value may occasionally occur, especially on the start-up of the machine. The switch will withstand these occasional surges if they are within the maximum allowable pressure rating of the switch. However, frequently applying this higher pressure will greatly reduce the life of the switch.



Service Temperature Limitations

Ambient: Min	-25°C (-13°F)	Max. +85°C (+185°F)
Pressure Media: Min.	-25°C (-13°F)	Max. +120°C (+250°F)

*Registered Trade Mark of Du Pont.

Technical Data

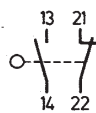
Electrical Contact Ratings

Type	Contact Arrangement	AC Ratings				DC Ratings			
		120V	240V	415V	600V	125V	250V		
Single Pole, double throw. One circuit normally open and one circuit normally closed. Each circuit must be used on the same polarity.		Max Make Current A	60	30	17	12	Max Make & Break Current A	0.22	0.11
		Max Break Current A	6	3	1.7	1.2			
		Continuous Rating A	10	10	10	10			
Double Pole, double throw. Each pole is electrically separate from the other and may be used on opposite polarities. The contacts on each pole are single pole double throw. Each circuit must be used on the same polarity.		Max Make Current A	60	30	17	12	Max Make & Break Current A	0.11	0.05
		Max Break Current A	6	3	1.7	1.2			
		Continuous Rating A	10	10	10	10			

3b

Dimensions

Class 9012 GAWM-1, 21
Class 9012 GDWM-1, 21

Weight 1.473 kg.

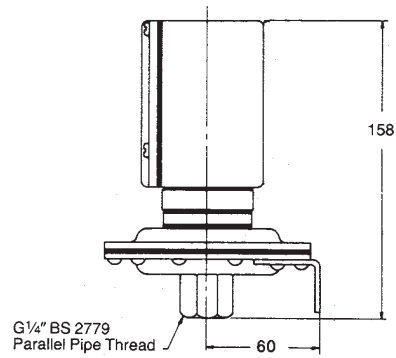
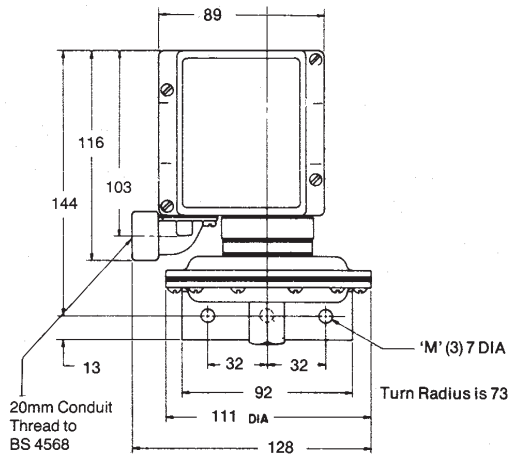

Class 9012 Type GBWM-1, 2, 21, 22
Class 9012 Type GEWM-1, 2, 21, 22

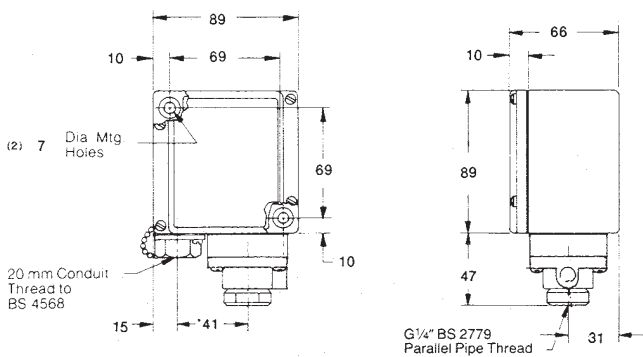

Class 9012 Type GAWM-5, 6, 25, 26
Class 9012 Type GDWM-5, 6, 25, 26

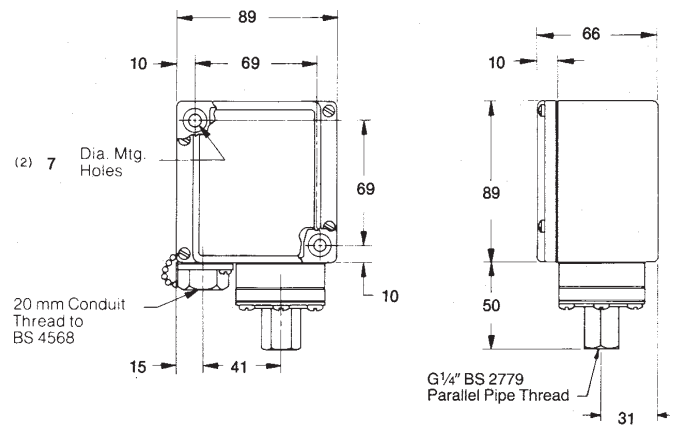

Class 9012 Type GCWM, GFWM

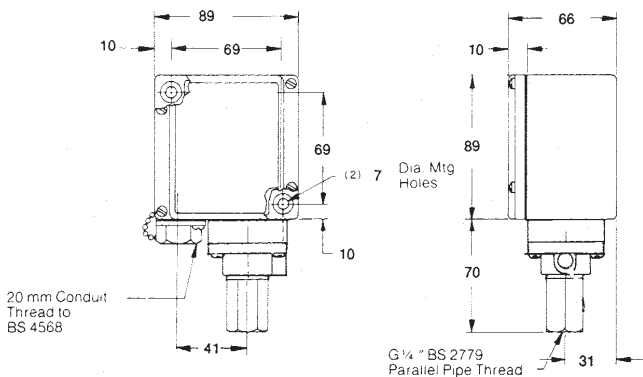

Class 9012 Type GAWM-2, 4, 22, 24
Class 9012 Type GDWM-2, 4, 22, 24

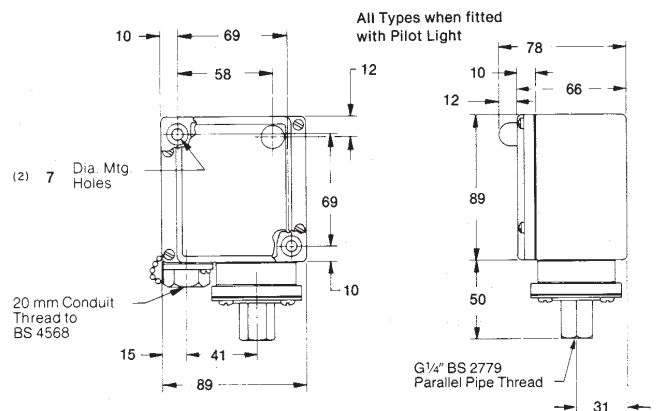

Dimensions in mm
Net Weight 0.82kg

All Dimensions in mm

3c



Type FSG-2

PRESSURE SWITCHES
Type FSG

- Suitable for direct control of small motors
- Suitable for use on air or water
- Designed for control of electrically driven water pumps

Water Pump Pressure Switches FSG..... 3c2

Water Pump Pressure Switches

Type FSG Diaphragm Actuated Water Pump Pressure Switches

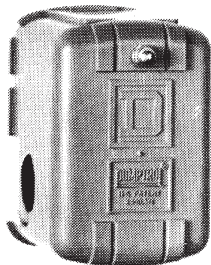

Type FSG-2

Application	Pipe Connections	Poles	Cut-out Pressure Range (PSIG)	Differential† (PSIG)	Cut-out Pressure Range (Bars)	Differential† (Bars)	Order Class 9013 Type...
Domestic Water Pumps Water or Air.	1/4"-18 NPSF internal thread	2	1.5-13	5-20	0.1 -0.9	0.34-1.38	FSG-42P
		2	20 -65	15-30	1.38-4.48	1.03-2.07	FSG-2

† Minimum differentials shown are at low end of pressure range. Differential widens as range increases.

Contacts open on increasing pressure

Application

Designed for the control of electrically driven water pumps, the Class 9013 devices are suitable for the direct control of motors in typical pump applications.

Enclosure - General purpose NEMA Type 1

Electrical Ratings Type FSG

Type FSG	Single Phase AC 110V		220-240V		Polyphase AC 220-240V		Direct Current 32V		115V		230V	
	HP	KW	HP	KW	HP	KW	HP	KW	HP	KW	HP	KW
Type FSG	1	0.75	1.5	1.1	3	2.2	0.25	0.18	0.25	0.18	0.25	0.18

Dimensions

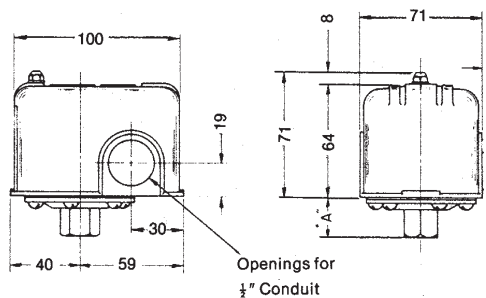

Swing Radius is 57

All Dimensions in mm

Type F
Net Weight - .5 kg

Ordering Instructions

State... Class and Type

Eg: Class 9013 Type FSG-2