

Maxseal Solenoid Valves

Up to 4"



Maxseal Technology from FC^x Thompson Valves.



An Industry Standard Evolved from an Original Concept.

- Original, direct-acting design specified throughout industry for process control and related instrumentation.
- Exacting standards in chemical, gas turbine, naval, nuclear power, offshore, petrochemical and pharmaceutical applications.
- 40 year track record of effective safety in hazardous service duties.
- 40 years experience in North Sea environments.
- A worldwide market leader for proven performance and reliability.



Approvals and Certification.



Maxseal solenoid valves are designed for use in hazardous areas and conform to BASEEFA / SIRA and European CENELEC specifications.



Factory Mutual Research Corporation Approved.



Maxseal valves comply with the following EC directives and are therefore entitled to bear the CE mark.

Machinery Directive	89/392/EEC
Electromagnetic Compatibility Directive (EMCD)	89/336/EEC as amended by 92/31/EEC and 93/68/EEC
Low Voltage Directive (LVD)	72/23/EEC as amended by 93/68/EEC
ATEX Directive	94/9/EC



PHOTOGRAPH COURTESY OF ALSTOM POWER UK LTD



We are here to help!
When you've browsed this overview, talk to us about the best solution for your system.

The Industry Standard Maxseal Solenoid Valve.

Model Shown:

ICO4S 1/4" Stainless Steel EEx d Valve.

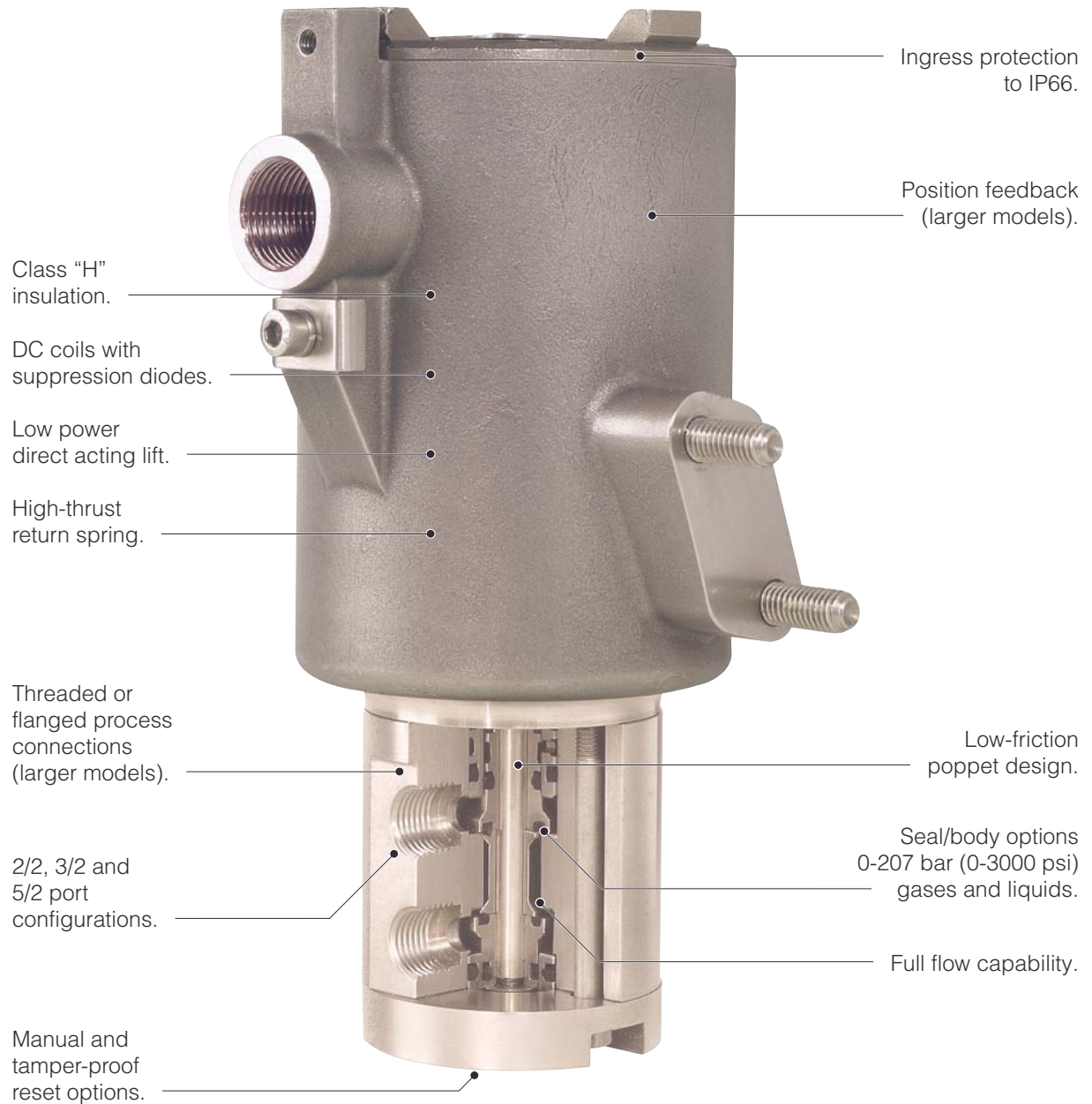

- Proven reliability of the original direct-acting solenoid valve design.
- Certification and approvals for use in hazardous areas.
- Choice of materials to suit process requirements.
- Compact and lightweight unit.

 **We are here to help!**
www.fcx-thompson-valves.com

The Power to Perform.

FC^x Thompson Valves is part of the FC^x Flow Control division of Charles Baynes plc, a leading supplier of specialist flow control products with a network of global resources.

FC^x Thompson Valves packaged and component solutions are specified worldwide for their high technical added value and fitness for purpose in exacting control and instrumentation applications.

A Tradition of Integrity.

Maxseal solenoid valves produced by FC^x Thompson Valves consistently set rigorous standards for process management in the most demanding environments: aerospace, defense, gas turbine, mining, nuclear power, offshore and petrochemical industries.



PHOTOGRAPH COURTESY OF ALSTOM POWER UK LTD

www.fcx-thompson-valves.com



i We are here to help!
sales@fcx-thompson-valves.com
+44 1202 697521

Safe, Reliable and Cost-Effective Solutions.

Maxseal solenoid valves from FC^x Thompson Valves are market leaders. In critical duties such as oil and gas, they perform on most offshore production platforms in the North Sea, as well as in all major onshore terminals.

Absorption equipment
fuel systems
pipeline shut-off
water treatment
Absorption equipment
Gas turbines, generators and compressors
water treatment
fire safety and deluge systems
fire safety and deluge systems

Contents.

				Page
Maxseal Technology from FC^x Thompson Valves				2
Technical Information				
Hazardous area	Model	Connection size	Operating pressure, bar (psi)	
Zone 0	ICO2S	1/4" NPT	Main valve 0 - 20 (0 - 290) Pilot valve 2 - 7 (29 - 101.5)	6
Zone 1	ICO4D	1/4" NPT	0 - 20 (0 - 290)	8
	ICO4S	1/4" NPT	0 - 20 (0 - 290)	10
	ICO4D	1/2" NPT	0 - 20 (0 - 290)	12
	ICO4S	1/2" NPT	0 - 20 (0 - 290)	14
	SOV 1-2	1/2" - 3/4" NPT	0 - 20 (0 - 290)	16
	SOV 3-6	1/2" - 3/4" flanged 1" - 2" NPT 1" - 3" flanged	0 - 20 (0 - 290)	18
Zones 1 and 2	POICO4	1/4" NPT	Main valve 0 - 20 (0 - 290) Pilot valve 2 - 10 (29 - 145)	20
	Dual shuttle valve	1/4" NPT	Main valve 0 - 10 (0 - 145) Pilot valve 0 - 10 (0 - 145)	22
	POV	1/2" - 2" NPT 1/2" - 4" flanged	Main valve 0 - 20 (0 - 290) Pilot valve 2 - 10 (29 - 145)	24
Zone 2	ICO4N	1/4" NPT	0 - 20 (0 - 290)	26
	SOV 1-6	1" - 2" NPT 1" - 4" flanged	0 - 20 (0 - 290)	28
Unclassified	SOV 1-6 (weatherproof)	As SOV 1-6, Zone 2	As SOV 1-6, Zone 2	28
	AOV	1/4" NPT	Main valve 0 - 20 (0 - 290) Pilot signal 2 - 10 (29 - 145)	30
	AOV	1/2" - 2" NPT 1/2" - 4" flanged	Main valve 0 - 20 (0 - 290) Pilot signal 2 - 10 (29 - 145)	32
Optional Valve Features				
	Automatic			34
	Lever Manual Reset			34
	Lever Manual Override			34
	Automatic Latching Lever			34
	Tamperproof Manual Reset			34
Special Valve Features				
	Indicating Switches			35
	High Temperature Spacer			35
	Horizontal Mounting			35
Hazardous Area Guidelines				
	Intrinsic Safety			36
	Installation Guidelines			37
	Coding System			38
Valve Flow Characteristics				
40				
Valve Flow Performance Charts				
	1. Air Flow, ICO4 1/4", Low Pressure			43
	2. Air Flow, ICO4 1/2", Low Pressure			43
	3. Liquid Flow, ICO4 1/4", Low Pressure			44
	4. Liquid Flow, ICO4 1/4", High Pressure			44
	5. Flow Test, ICO4 1/4"			45
	6. Flow Test, ICO4 1/2"			46
	7. Flow Test, ICO4 1/2"			46
Conversion Chart				
47				

turbines, generators and compressors
 pneumatic cylinders pipeline shut-off emergency shutdown
 Absorption emergency shutdown systems pipeline shut-off
 Air conditioners and dryers Absorption equipment
 pneumatic cylinders Air conditioners and dryers
 Fuel systems gas turbines, generators and compressors
 pneumatic cylinders

Maxseal Instrument Changeover and Process Control Valve for Hazardous Areas EEx ia



Model ICO2S 1/4" - 2"

Certification



II 1G
SIRA / CENELEC approved
EEx ia IIC T6 T_a (-40°C to +64°C)
Complies with EN 50014:1997 (incl. amendments A1 and A2), EN 50020:1994 and EN 50284:1999
Complies with ATEX Directive 94/9/EC
Complies to Electrical Safety Standard IEC 1010
Assessed compliant to Pressure Equipment Directive 97/23/EC
FM approved to I.S. Class I Division 1 Groups A.B.C.D.

Description

A pilot operated solenoid valve certified for use with hazardous gases.

5-port

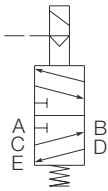

3-port

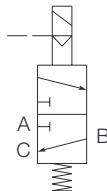

2-port, EO

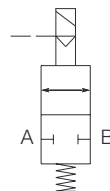

2-port, EC

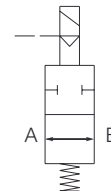

Standard Features

Port thread (main body)	1/4" NPT
Port configuration	3/2 Uni
Operating pressure	
Main valve	0 - 20 bar(g) (0 - 290 psi)
Pilot valve	2 - 7 bar(g) (29 - 101.5 psi)
Actuation method	Pilot assisted
Valve material	Stainless steel BS EN 10088
Media	
Main valve	Liquids and gases
Pilot valve	2 - 7 bar (29 - 101.5 psi) clean and dry instrument air or inert gas
Seat / Seal material	High nitrile (Buna N)
Operating voltage	24V DC; 0.5W at 20°C (68°F) through barrier
Conduit / Signal entry	M20 x 1.5 mm ISO (F) / 1/4" NPT
Paint finish	Unpainted
Coil housing material	Stainless steel BS 3146 ANC.4 BFC.316
Weight	3-port version: 3 kg (6.6 lb)
Cv value	0.8 (Kv 0.69)

Options

Port thread	1/4" - 2" BSPP / BSPT 1/2" - 2" NPT
Port configuration	5/2 Uni; 2/2 EO; 2/2 EC
Actuation method	Autolatch, lever manual reset (LMR), lever manual override (LMO), tamperproof manual reset (see "Optional Valve Features")
Valve material	Brass BS EN 12163: 1998
Seat / Seal material	Viton®, nylon 66 (high pressure seat only) Alternative materials available on request
Conduit / Signal entry	1/2" NPT
CV value (main valve)	
1/4" model	0 - 50 bar(g) (0 - 725 psi) = 0.6 (Kv = 0.5) 0 - 103/207 bar(g) (0 - 1494/3000 psi) = 0.28 (Kv = 0.24)
1/2" - 2" models	Please contact us

Viton® is a registered trademark of DuPont Dow Elastomers LLC.



Maxseal
Instrument Changeover and Process Control Valve for Hazardous Areas
EEx ia
ICO2S 1/4" - 2"

Technical Specification

Protection	Ingress IP66 / X8. NEMA 4X Surge suppression diodes	
Response times (typical, dependent on coil size)	Pull-in < 150 ms Drop-out < 80 ms	
Response times settings	Pull-in: within 87.5% of nominal (factory set at less than 75% of nominal) Drop-out: normally 10-20% of nominal	
Operating pressure ranges (main valve)		
1/4" model	0 - 20 bar(g)	(0 - 290 psi) (standard)
	0 - 50 bar(g)	(0 - 725 psi) (option)
	0 - 103 bar(g)	(0 - 1494 psi) (option)
	0 - 207 bar(g)	(0 - 3000 psi) (option)
1/2" - 2" models	Please contact us	

Dimensions in mm (inches)

(3/2 Uni 1/4" configuration illustrated)

A typical basic installation would comprise a 24V DC power supply, control switch or relay, and an EEx.ia 300Ω 28V barrier.

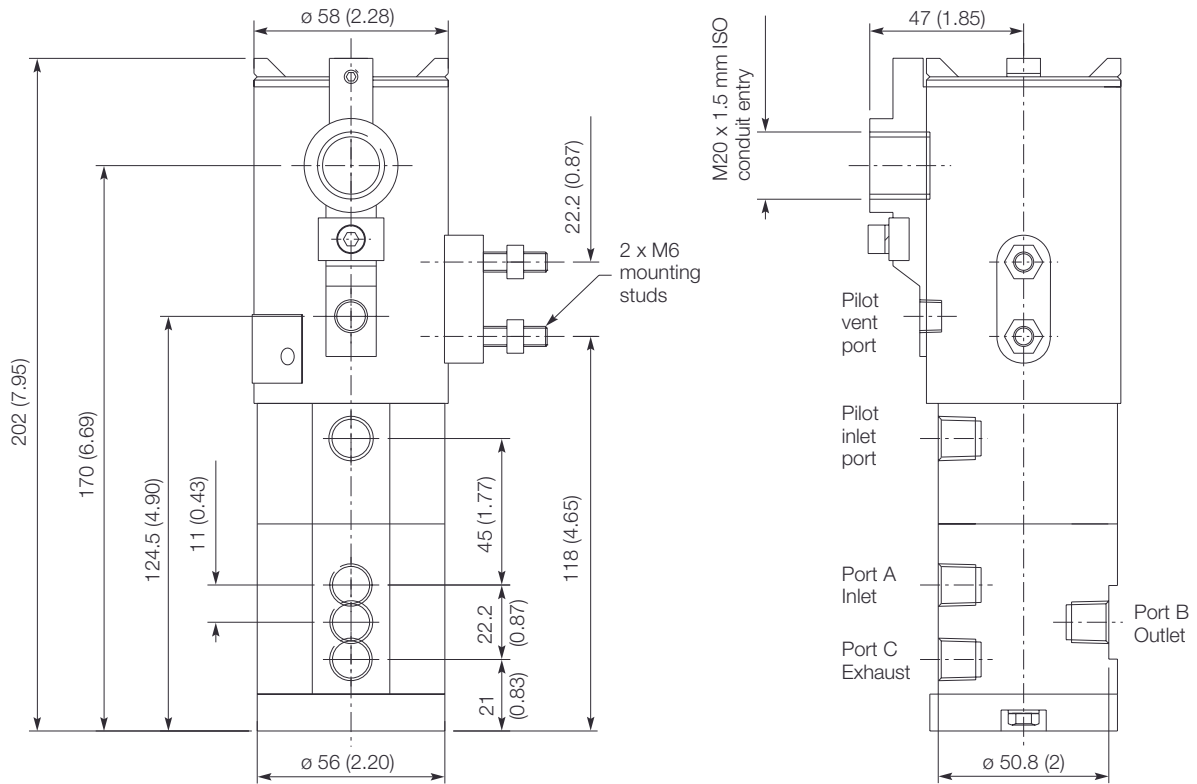

For your convenience, Operation and Maintenance instructions are included with each valve.

Maxseal Instrument Changeover and Process Control Valve for Hazardous Areas EEx d



Model ICO4D 1/4"

Certification



II 2G
 EECS (BASEEFA) / SIRA CENELEC approved
 EEx d IIC T6 ($T_a = -60^{\circ}\text{C}$ to $+40^{\circ}\text{C}$) or
 EEx d IIC T4 ($T_a = -60^{\circ}\text{C}$ to $+90^{\circ}\text{C}$)
 Complies with BS 5501: Part 5:1977, EN 50014:1977 (amendments 1 and 2)
 and EN 50018:1994
 Complies with ATEX Directive 94/9/EC

Description

A direct-acting solenoid valve certified for hazardous area use as well as general air and gas purposes in the offshore and petrochemical industries.

5-port

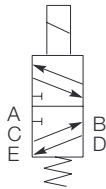

3-port

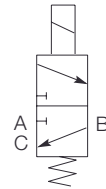

2-port, EO



2-port, EC



Standard Features

Port thread	1/4" NPT
Port configuration	3/2 Uni
Operating pressure	0 - 20 bar(g) (0 - 290 psi)
Actuation method	Automatic
Valve material	Stainless steel BS EN 10088
Seat / Seal material	High nitrile (Buna N)
Operating voltage	24V DC; 4.5W at 20°C (68°F)
Conduit / Signal entry	M20 x 1.5 mm ISO (F)
Paint finish	Standard (green) 40 µm
Coil housing material	Cast iron BS EN 1561: 1997
Weight	3-port version: 5 kg (11 lb)
Cv value	0.8 (Kv 0.69)

Options

Port thread	1/4" BSPP; 1/4" BSPT
Port configuration	5/2 Uni; 2/2 EO; 2/2 EC
Actuation method	Autolatch, lever manual reset (LMR), lever manual override (LMO), tamperproof manual reset (see "Optional Valve Features")
Valve material	Brass BS EN 12163: 1998
Seat / Seal material	Viton®, nylon 66 (high pressure seat only) Alternative materials available on request
Operating voltages	DC: 12, 24, 48, 110, 125, 240 AC: 24, 50, 110, 240, 440
Conduit / Signal entry	1/2" NPT, 13.5 PG
Paint	Epoxy (light grey) 150 µm
CV value	0 - 50 bar(g) (0 - 725 psi) = 0.6 (Kv = 0.5) 0 - 103/207 bar(g) (0 - 1494/3000 psi) = 0.28 (Kv = 0.24)

Viton® is a registered trademark of DuPont Dow Elastomers LLC.



Maxseal
Instrument Changeover and Process Control Valve for Hazardous Areas
EEx d
ICO4D 1/4"

Technical Specification

Protection	Ingress IP65 - IP68 Surge suppression diodes	
Response times (typical, dependent on coil size)	Pull-in < 150 ms Drop-out < 80 ms	
Response times settings	Pull-in: within 87.5% of nominal (factory set at less than 75% of nominal) Drop-out: normally 10-20% of nominal	
Operating pressure ranges	0 - 20 bar(g) (0 - 290 psi) (standard) 0 - 50 bar(g) (0 - 725 psi) (option) 0 - 103 bar(g) (0 - 1494 psi) (option) 0 - 207 bar(g) (0 - 3000 psi) (option)	

Dimensions in mm (inches)

(3/2 Uni configuration illustrated)

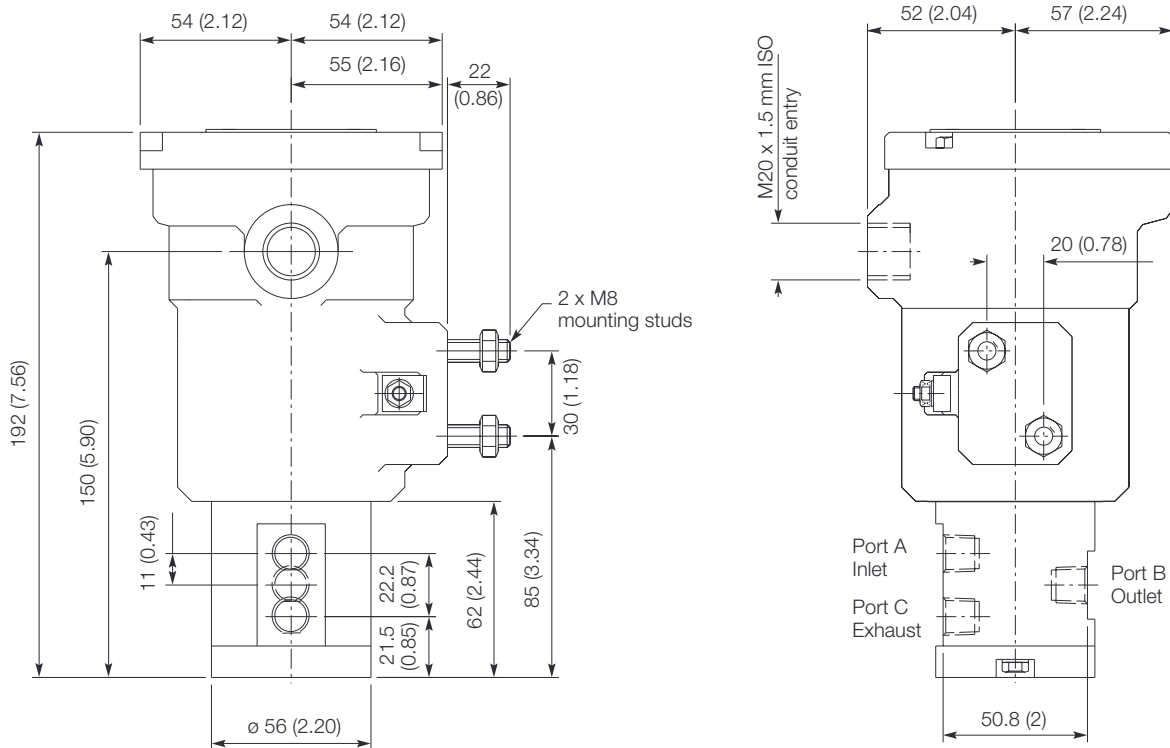

Remember that overhaul kits and replacement coil housing assemblies are available.

Maxseal Instrument Changeover and Process Control Valve for Hazardous Areas EEx d



Model ICO4S 1/4"

Certification



II 2G
 EECS (BASEEFA) / SIRA CENELEC approved
 EEx d IIC T6 ($T_a = -60^{\circ}\text{C}$ to $+48^{\circ}\text{C}$) or
 EEx d IIC T4 ($T_a = -60^{\circ}\text{C}$ to $+90^{\circ}\text{C}$)
 Complies with EN 50014:1997 (amendments 1 and 2) and EN 50018:1994
 Complies with ATEX Directive 94/9/EC
 FM approved to Class I Division 1 Groups A, B, C, D

Description

A direct-acting solenoid valve certified for hazardous area use as well as general air and gas purposes in the offshore and petrochemical industries.

5-port

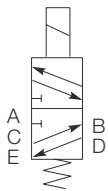

3-port

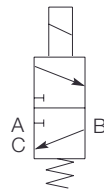

2-port, EO



2-port, EC



Standard Features

Port thread	1/4" NPT
Port configuration	3/2 Uni
Operating pressure	0 - 20 bar(g) (0 - 290 psi)
Actuation method	Automatic
Valve material	Stainless steel BS EN 10088
Seat / Seal material	High nitrile (Buna N)
Operating voltage	24V DC; 4.5W at 20°C (68°F)
Conduit / Signal entry	M20 x 1.5 mm ISO (F)
Paint finish	Unpainted
Coil housing material	Stainless steel BS 3146 ANC.4 BFC.316
Weight	3-port version: 5 kg (11 lb)
Cv value	0.8 (Kv 0.69)

Options

Port thread	1/4" BSPP; 1/4" BSPT
Port configuration	5/2 Uni; 2/2 EO; 2/2 EC
Actuation method	Autolatch, lever manual reset (LMR), lever manual override (LMO), tamperproof manual reset (see "Optional Valve Features")
Valve material	Brass BS EN 12163: 1998
Seat / Seal material	Viton®, nylon 66 (high pressure seat only) Alternative materials available on request
Operating voltages	DC: 12, 24, 48, 110, 125, 240 AC: 24, 50, 110, 240, 440
Conduit / Signal entry	1/2" NPT, 13.5 PG
CV value	0 - 50 bar(g) (0 - 725 psi) = 0.6 (Kv = 0.5) 0 - 103/207 bar(g) (0 - 1494/3000 psi) = 0.28 (Kv = 0.24)

Viton® is a registered trademark of DuPont Dow Elastomers LLC.



Maxseal
Instrument Changeover and Process Control Valve for Hazardous Areas
EEx d
ICO4S 1/4"

Technical Specification

Protection	Ingress IP65 / X8. NEMA 4X Surge suppression diodes	
Response times (typical, dependent on coil size)	Pull-in < 150 ms Drop-out < 80 ms	
Response times settings	Pull-in: within 87.5% of nominal (factory set at less than 75% of nominal) Drop-out: normally 10-20% of nominal	
Operating pressure ranges	0 - 20 bar(g) (0 - 290 psi) (standard) 0 - 50 bar(g) (0 - 725 psi) (option) 0 - 103 bar(g) (0 - 1494 psi) (option) 0 - 207 bar(g) (0 - 3000 psi) (option)	

Dimensions in mm (inches)

(3/2 Uni configuration illustrated)

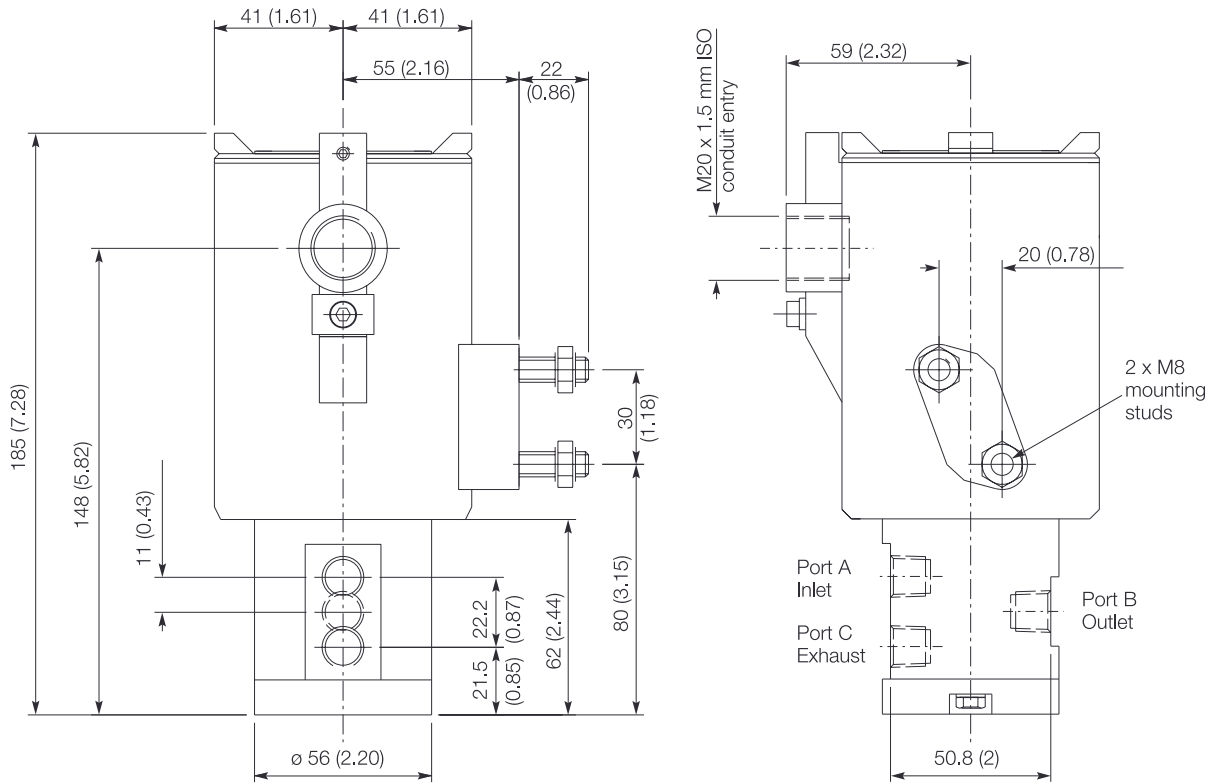

We recommend installing a strainer or filter as close as possible to valve inlet. While protecting seating areas from potential damage, this helps maintain **air quality** - Talk to us about filtration!

Maxseal Instrument Changeover and Process Control Valve for Hazardous Areas EEx d

Model ICO4D 1/2"



Certification



II 2G
 EECS (BASEEFA) / SIRA CENELEC approved
 EEx d IIC T6 ($T_a = -60^{\circ}\text{C}$ to $+40^{\circ}\text{C}$) or
 EEx d IIC T4 ($T_a = -60^{\circ}\text{C}$ to $+90^{\circ}\text{C}$)
 Complies with BS 5501: Part 5:1977, EN 50014:1977 (amendments 1 and 2)
 and EN 50018:1994
 Complies with ATEX Directive 94/9/EC

Description

A direct-acting solenoid valve certified for hazardous area use as well as general air and gas purposes in the offshore and petrochemical industries.

3-port

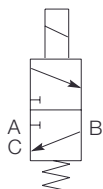

2-port, EO

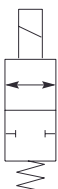

2-port, EC



Standard Features

Port thread	1/2" NPT
Port configuration	3/2 Uni
Operating pressure	0 - 20 bar(g) (0 - 290 psi)
Actuation method	Automatic
Valve material	Stainless steel BS EN 10088
Seat / Seal material	High nitrile (Buna N)
Operating voltage	24V DC; 15.2W at 20°C (68°F)
Conduit / Signal entry	M20 x 1.5 mm ISO (F)
Paint finish	Standard (green) 40 µm
Coil housing material	Cast iron BS EN 1561: 1997
Weight	3-port version: 8 kg (17.6 lb)
Cv value	4.2 (Kv 3.61)

Options

Port thread	1/2" BSPP; 1/2" BSPT
Port configuration	2/2 EO; 2/2 EC
Actuation method	Autolatch, lever manual reset (LMR), lever manual override (LMO), tamperproof manual reset (see "Optional Valve Features")
Valve material	Brass BS EN 12163: 1998
Seat / Seal material	Viton® Alternative materials available on request
Operating voltages	DC: 12, 24, 48, 110, 125, 240 AC: 24, 50, 110, 240, 440
Conduit / Signal entry	1/2" NPT, 13.5 PG
Paint	Epoxy (light grey) 150 µm
CV value	0 - 50 bar(g) (0 - 725 psi) = 3.8 (Kv = 2.7) non-universal

Viton® is a registered trademark of DuPont Dow Elastomers LLC.



Maxseal
Instrument Changeover and Process Control Valve for Hazardous Areas
EEx d
ICO4D 1/2"

Technical Specification

Protection	Ingress IP65 - IP68 Surge suppression diodes
Response times (typical, dependent on coil size)	Pull-in < 150 ms Drop-out < 80 ms
Response times settings	Pull-in: within 87.5% of nominal (factory set at less than 75% of nominal) Drop-out: normally 10-20% of nominal
Operating pressure ranges	0 - 20 bar(g) (0 - 290 psi) (standard) 0 - 50 bar(g) (0 - 725 psi) non-universal (option)

Dimensions in mm (inches)

(3/2 Uni configuration illustrated)

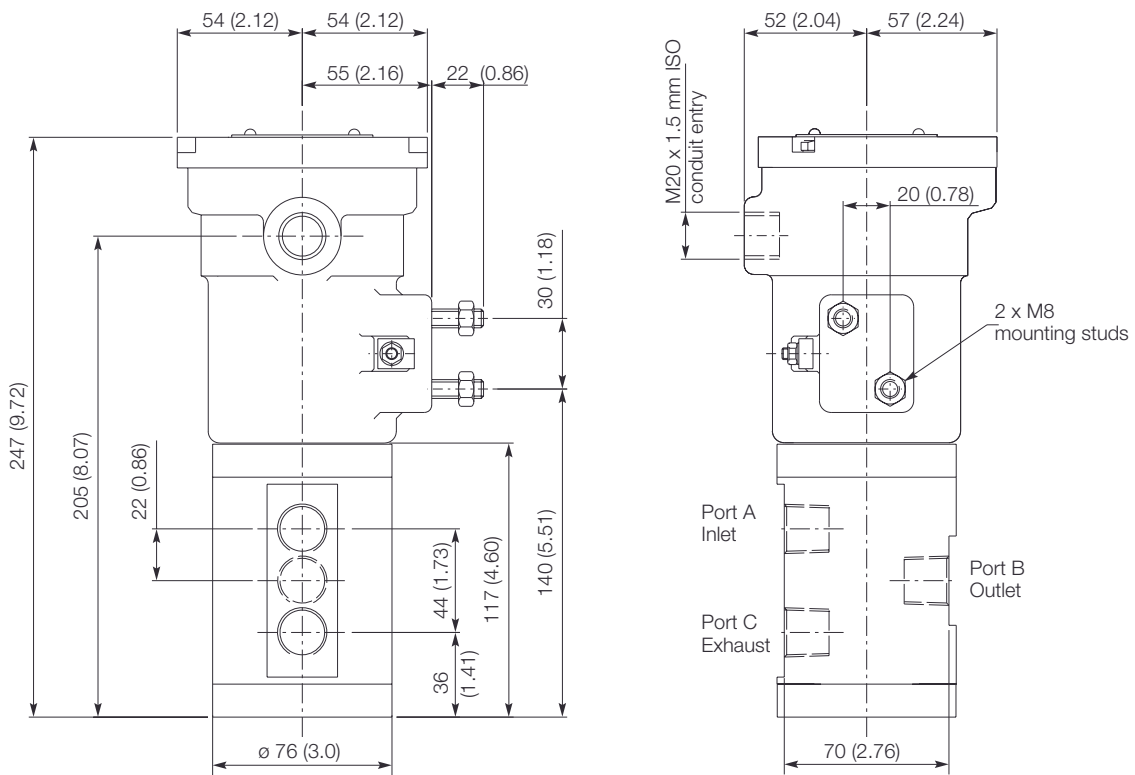

For your convenience, Operation and Maintenance instructions are included with each valve.

Maxseal Instrument Changeover and Process Control Valve for Hazardous Areas EEx d



Model ICO4S 1/2"

Certification



II 2G
 EECS (BASEEFA) / SIRA CENELEC approved
 EEx d IIC T6 ($T_a = -60^{\circ}\text{C}$ to $+48^{\circ}\text{C}$) or
 EEx d IIC T4 ($T_a = -60^{\circ}\text{C}$ to $+90^{\circ}\text{C}$)
 Complies with EN 50014:1997 (amendments 1 and 2) and EN 50018:1994
 Complies with ATEX Directive 94/9/EC
 FM approved to Class I Division 1 Groups A. B. C. D

Description

A direct-acting solenoid valve certified for hazardous area use as well as general air and gas purposes in the offshore and petrochemical industries.

3-port

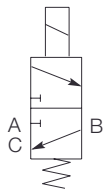

2-port, EO

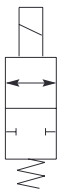

2-port, EC



Standard Features

Port thread	1/2" NPT
Port configuration	3/2 Uni
Operating pressure	0 - 20 bar(g) (0 - 290 psi)
Actuation method	Automatic
Valve material	Stainless steel BS EN 10088
Seat / Seal material	High nitrile (Buna N)
Operating voltage	24V DC; 15.2W at 20°C (68°F)
Conduit / Signal entry	M20 x 1.5 mm ISO (F)
Paint finish	Unpainted
Coil housing material	Stainless steel BS 3146 ANC.4 BFC.316
Weight	3-port version: 8 kg (17.6 lb)
Cv value	4.2 (Kv 3.61)

Options

Port thread	1/2" BSPP; 1/2" BSPT
Port configuration	2/2 EO; 2/2 EC
Actuation method	Autolatch, lever manual reset (LMR), lever manual override (LMO), tamperproof manual reset (see "Optional Valve Features")
Valve material	Brass BS EN 12163: 1998
Seat / Seal material	Viton® Alternative materials available on request
Operating voltages	DC: 12, 24, 48, 110, 125, 240 AC: 24, 50, 110, 240, 440
Conduit / Signal entry	1/2" NPT, 13.5 PG
CV value	0 - 50 bar(g) (0 - 725 psi) = 3.8 (Kv = 2.7) non-universal

Viton® is a registered trademark of DuPont Dow Elastomers LLC.



Maxseal
Instrument Changeover and Process Control Valve for Hazardous Areas
EEx d
ICO4S 1/2"

Technical Specification

Protection	Ingress IP65 / X8. NEMA 4X Surge suppression diodes
Response times (typical, dependent on coil size)	Pull-in < 150 ms Drop-out < 80 ms
Response times settings	Pull-in: within 87.5% of nominal (factory set at less than 75% of nominal) Drop-out: normally 10-20% of nominal
Operating pressure ranges	0 - 20 bar(g) (0 - 290 psi) (standard) 0 - 50 bar(g) (0 - 725 psi) non-universal (option)

Dimensions in mm (inches)

(3/2 Uni configuration illustrated)

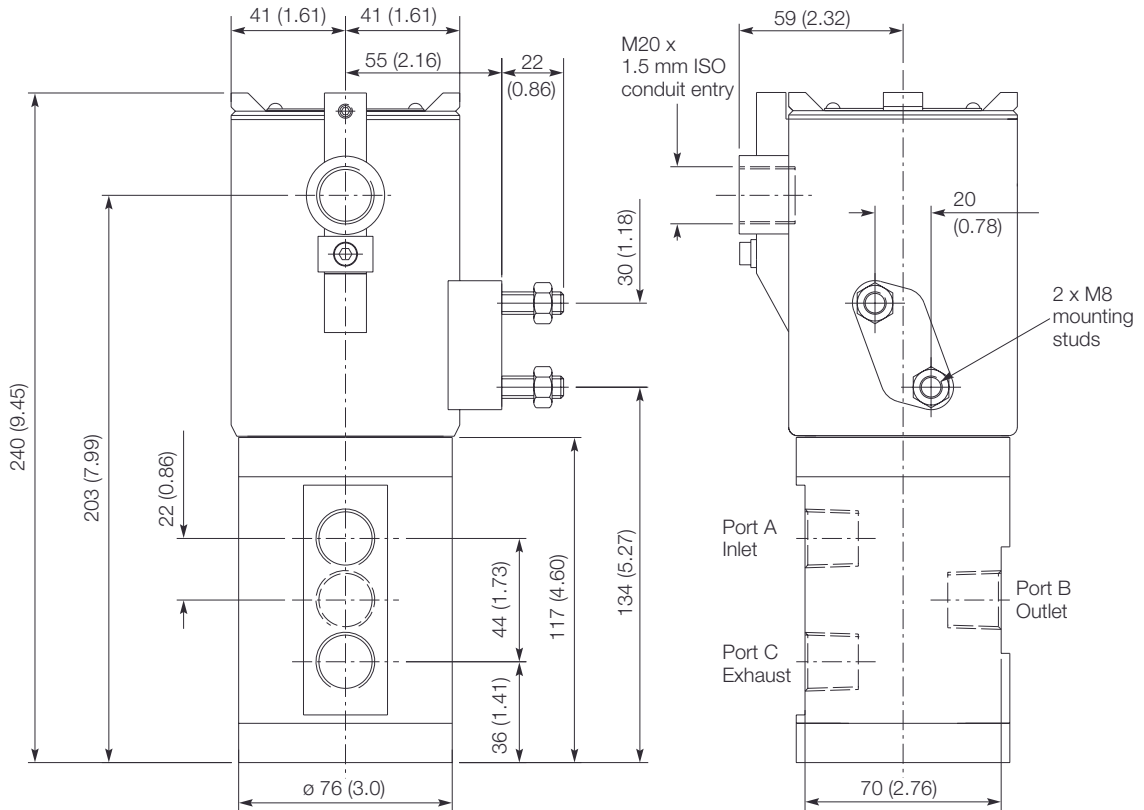

Remember that overhaul kits and replacement coil housing assemblies are available.

Maxseal Direct Solenoid-Operated Control Valve for Hazardous Areas EEx d



Model SOV, Sizes 1 & 2 (1/2" - 3/4")

Certification

EECS (BASEEFA) / GENELEC approved
EEx d IIC T6 or EEx d IIC T4 (T_a = 90°C)
Complies with EN 50014:1997 and EN 50018:1977

Description

A direct-acting solenoid valve certified for hazardous area use as well as general air and gas purposes in the offshore and petrochemical industries.

5-port

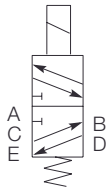

3-port

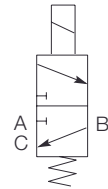

2-port, EO



2-port, EC



Standard Features

Port thread	1/2" - 3/4" NPT
Port configuration	3/2 Uni
Operating pressure	0 - 20 bar(g) (0 - 290 psi)
Actuation method	Automatic
Valve material	Stainless steel BS EN 10088
Seat / Seal material	High nitrile (Buna N)
Operating voltage	
Size 1	24V DC; 18W at 20°C (68°F)
Size 2	24V DC; 25W at 20°C (68°F)
Conduit / Signal entry	M20 x 1.5 mm ISO (F)
Paint finish	Standard (green) 40 µm
Coil housing material	Cast iron BS EN 1561: 1997
Weight (approx.)	3-port version: 20 kg (44 lb)
Cv value at 20 bar (290 psi)	
1/2" model	3.2 (Kv 2.7)
3/4" model	6.8 (Kv 5.8)

Options

Port connections	
Female threaded	1/2" BSPP; 1/2" BSPT
Flanged	1/2" - 3/4" BS 10, BS 1560 or BS 4504
Port configuration	5/2 Uni; 2/2 EO; 2/2 EC
Actuation method	Autolatch, lever manual reset (LMR), lever manual override (LMO), tamperproof manual reset (see "Optional Valve Features")
Valve material	Brass BS EN 12163: 1998 Flanged/cast bodies available on request
Seat / Seal material	Viton®, nylon 66 (high pressure seat only) Alternative materials available on request
Operating voltages	DC: 12, 24, 48, 110, 125, 240 AC: 24, 50, 110, 240, 440
Conduit / Signal entry	1/2" NPT, 13.5 PG
Paint	Epoxy (light grey) 150 µm
CV value	0 - 50 bar(g) (0 - 725 psi) + Please contact us

Viton® is a registered trademark of DuPont Dow Elastomers LLC.



Maxseal
Direct Solenoid-Operated Control Valve for Hazardous Areas
EEx d
SOV, Sizes 1 & 2 (1/2" - 3/4")

Technical Specification

Protection	Ingress IP65 - IP68 Surge suppression diodes
Response times	Pull-in: please contact us Drop-out: please contact us
Response times settings	Pull-in: within 87.5% of nominal (factory set at less than 75% of nominal) Drop-out: normally 10-20% of nominal
Operating pressure ranges	0 - 20 bar(g) (0 - 290 psi) (standard) 0 - 50 bar(g) (0 - 725 psi) bar stock body (option) 0 - 103 bar(g) (0 - 1494 psi) bar stock body (option) 0 - 207 bar(g) (0 - 3000 psi) bar stock body (option)

Dimensions in mm (inches)

(Size 2 3/4" solenoid 3/2 Uni configuration illustrated)

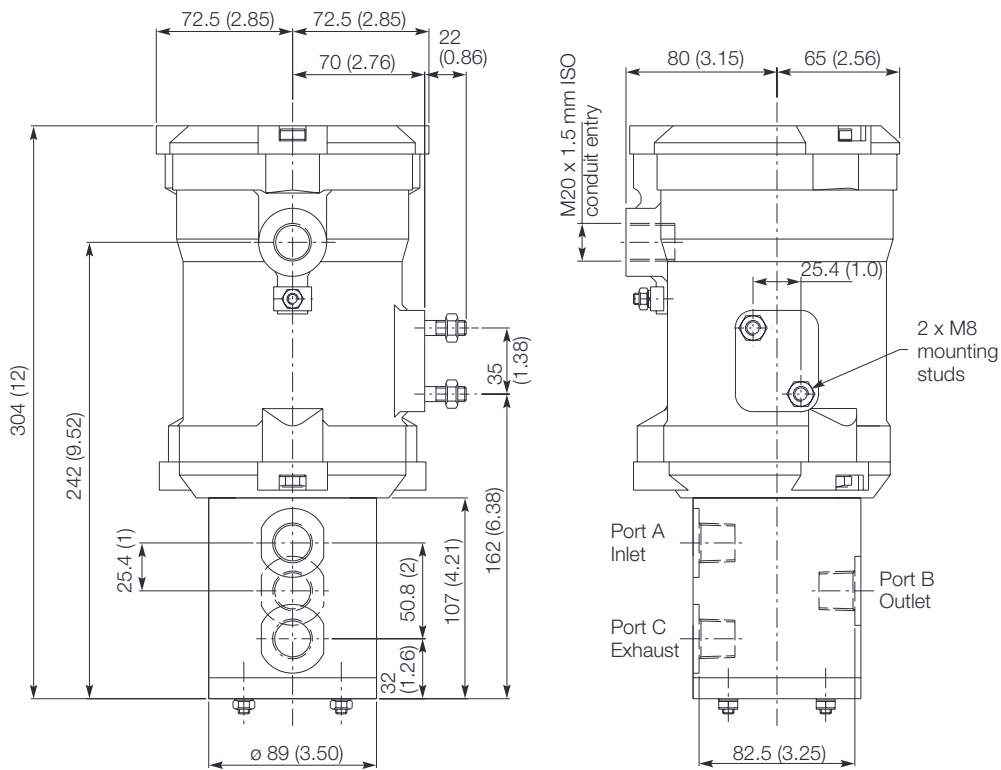

We recommend installing a strainer or filter as close as possible to valve inlet. While protecting seating areas from potential damage, this helps maintain **air quality** - Talk to us about filtration!

Maxseal Direct Solenoid-Operated Control Valve for Hazardous Areas Ex d



Model SOV, Sizes 3, 4, 5 & 6 (1" - 3")

Certification

EECS (BASEEFA) /
GENELEC approved
Ex d IIC T6 or
Ex d IIC T4 (T_a = 90°C)
Complies with
EN 50014:1997
and EN 50018:1977

Description

A direct-acting solenoid valve certified for hazardous area use as well as general air and gas purposes in the offshore and petrochemical industries.

Standard Features

Port thread	1" - 2" NPT
Port configuration	3/2 Uni
Operating pressure	0 - 20 bar(g) (0 - 290 psi)
Actuation method	Automatic
Valve material	Stainless steel BS EN 10088
Seat / Seal material	High nitrile (Buna N)
Operating voltage at 20°C (68°F)	
Size 3	24V DC; 40W
Size 4	24V DC; 75W
Size 5	24V DC; 100W
Size 6	24V DC; 150W
Conduit / Signal entry	M20 x 1.5 mm ISO (F)
Paint finish	Standard (green) 40 µm
Coil housing material	Cast iron BS EN 1561: 1997
Weight (approx.)	
Size 3	35 kg (77 lb)
Size 4	58 kg (128 lb)
Size 5	65 kg (144 lb)
Size 6	115 kg (254 lb)
Cv value at 20 bar (290 psi)	
1" model	12.8 (Kv 11)
1½" model	28 (Kv 24)
2" model	48 (Kv 41)
2½" model	70 (Kv 60)
3" model	100 (Kv 86)

5-port

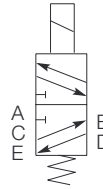

3-port

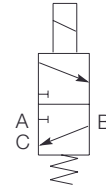

2-port, EO



2-port, EC



Options

Port connections	
Female threaded	1" - 2" BSPP / BSPT
Flanged	1" - 3" BS 10, BS 1560 or BS 4504
Port configuration	5/2 Uni; 2/2 EO; 2/2 EC
Actuation method	Autolatch, lever manual reset (LMR), lever manual override (LMO), tamperproof manual reset (see "Optional Valve Features")
Valve material	Brass BS EN 12163: 1998 Flanged/cast bodies available on request
Seat / Seal material	Viton®, nylon 66 (high pressure seat only) Alternative materials available on request
Operating voltages	DC: 12, 24, 48, 110, 125, 240 AC: 24, 50, 110, 240, 440
Conduit / Signal entry	½" NPT, 13.5 PG
Paint	Epoxy (light grey) 150 µm
CV value	50 bar(g) (725 psi) + Please contact us

Viton® is a registered trademark of DuPont Dow Elastomers LLC.



Maxseal
Direct Solenoid-Operated Control Valve for Hazardous Areas
EEx d
SOV, Sizes 3, 4, 5 & 6 (1" - 3")

Technical Specification

Protection	Ingress IP65 - IP68 Surge suppression diodes
Response times	Pull-in: please contact us Drop-out: please contact us
Response times settings	Pull-in: within 87.5% of nominal (factory set at less than 75% of nominal) Drop-out: normally 10-20% of nominal
Operating pressure ranges	0 - 20 bar(g) (0 - 290 psi) (standard) 0 - 50 bar(g) (0 - 725 psi) bar stock body (option) 0 - 103 bar(g) (0 - 1494 psi) bar stock body (option) 0 - 207 bar(g) (0 - 3000 psi) bar stock body (option)

Dimensions in mm (inches)

(Size 3 1" solenoid 3/2 Uni configuration illustrated. Double conduit thread for switches)

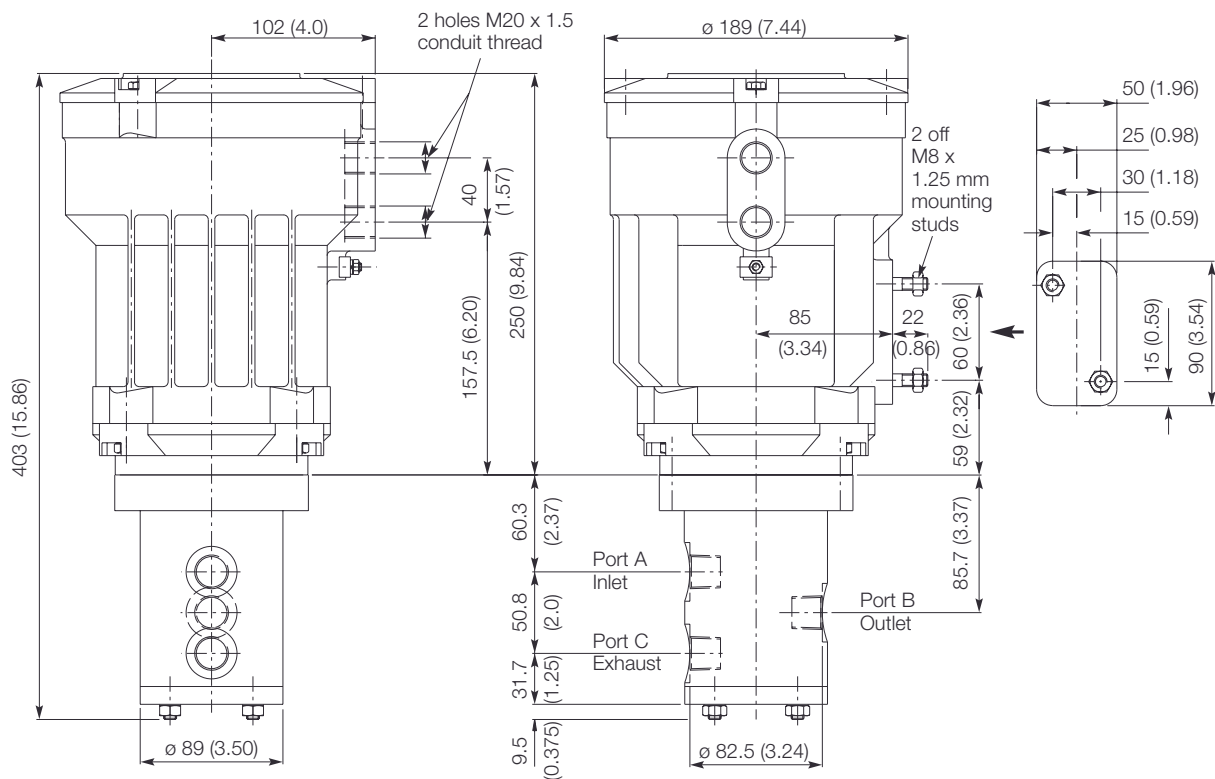

Remember that overhaul kits and replacement coil housing assemblies are available.

Maxseal Solenoid/Pilot-Operated Valve for Hazardous Areas EEx d, Ex N



Model POICO4 1/4"

Certification

Pilot operated valve optionally supplied with ICO4S, ICO4D or ICO4N. Refer to the relevant valves for certification data.

Description

A pilot-operated valve certified for hazardous area use as well as general liquid and gas purposes in the offshore and petrochemical industries.

5-port

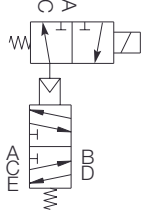

3-port

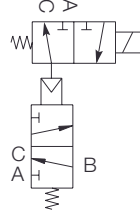

2-port, EO

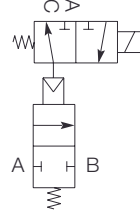

2-port, EC

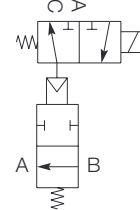

Standard Features

Port thread	1/4" NPT
Port configuration	3/2 Uni
Operating pressure	
Main valve	0 - 20 bar(g) (0 - 290 psi)
Pilot valve	2 - 10 bar(g) (29 - 145 psi)
Actuation method	Solenoid-operated, external pilot liquid/gas assisted
Valve material	Stainless steel BS EN 10088
Seat / Seal material	High nitrile (Buna N)
Operating voltage	24V DC; 4.5W (ICO4D/S) at 20°C (68°F)
Conduit / Signal entry	M20 x 1.5 mm ISO (F)
Paint finish	Standard (green) 40 µm
Coil housing material	
ICO4D and ICO4N	Cast iron BS EN 1561:1997
ICO4S	Stainless steel BS 3146 ANC.4 BFC.316
Weight	3-port version: 5 kg (11 lb)
Cv value	0.8 (Kv 0.69)

Options

Port thread (pilot body)	1/4" BSPP; 1/4" BSPT
Port configuration	5/2 Uni; 2/2 EO; 2/2 EC
Valve material	Brass BS EN 12163: 1998
Seat / Seal material	Viton®, nylon 66 (high pressure seat only) Alternative materials available on request
Operating voltages	DC: 12, 24, 48, 110, 125, 240 AC: 24, 50, 110, 240, 440
Conduit / Signal entry	1/2" NPT, 13.5 PG
Paint	Epoxy (light grey) 150 µm
CV value	0 - 50 bar(g) (0 - 725 psi) = 0.6 (Kv = 0.5) 0 - 103/207 bar(g) (0 - 1494/3000 psi) = 0.28 (Kv = 0.24)

Viton® is a registered trademark of DuPont Dow Elastomers LLC.



Maxseal
Solenoid/Pilot-Operated Valve for Hazardous Areas
EEx d, Ex N
POICO4 1/4"

Technical Specification

Protection	Ingress IP65 / IP68 Surge suppression diodes		
Response times (typical, dependent on coil size)	Pull-in < 150 ms Drop-out < 80 ms		
Response times settings	Pull-in: within 87.5% of nominal (factory set at less than 75% of nominal) Drop-out: normally 10-20% of nominal		
Operating pressure ranges			
Main valve	0 - 20 bar(g) Up to 207 bar(g)	(0 - 290 psi) (3000 psi)	2/2 and 3/2 ports 2/2 and 3/2 ports
Pilot signal	0 - 20 bar(g) 2 - 10 bar(g)	(0 - 290 psi) (29 - 145 psi)	5/2 port 2/2, 3/2 and 5/2 ports

Dimensions in mm (inches)

(ICO4N 3/2 Uni configuration illustrated)

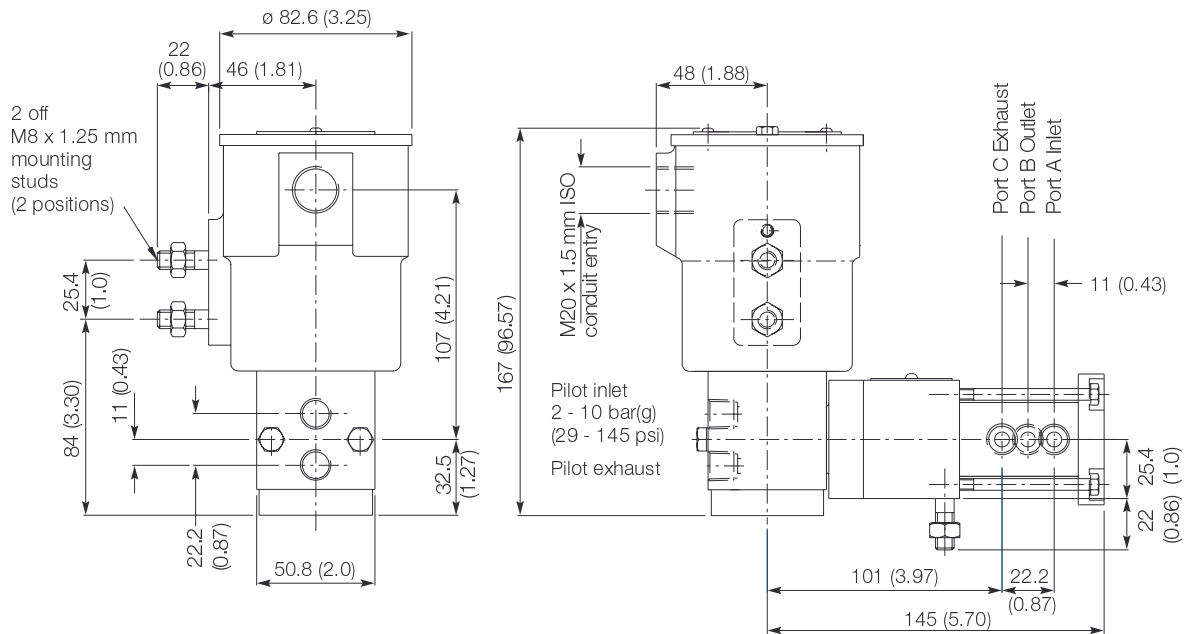

i Remember that overhaul kits and replacement coil housing assemblies are available.

Maxseal Dual Shuttle Valve for Hazardous Areas Ex d, Ex N



Dual Shuttle Valve 1/4" - 1/2"

Certification

Dual shuttle valve optionally supplied with ICO4S, ICO4D or ICO4N. Refer to the relevant valves for certification data.

Description

A valve certified for hazardous area use as well as general liquid and gas purposes in the offshore and petrochemical industries.

5-port

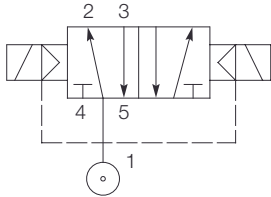

3-port

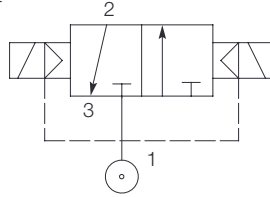

Standard Features

Port thread	
Solenoid valve	1/4" NPT
Shuttle valve (female)	1/4" NPT
Port configuration	
	3/2
Operating pressure	
Main valve	0 - 10 bar(g) (0 - 145 psi)
Pilot valve	2 - 10 bar(g) (29 - 145 psi)
Actuation method	
	Solenoid-operated, internal pilot gas assisted
Valve material	
	Stainless steel BS EN 10088
Seat / Seal material	
	High nitrile (Buna N)
Operating voltage	
	24V DC; 4.5W (ICO4D/S) at 20°C (68°F)
Conduit / Signal entry	
	M20 x 1.5 mm ISO (F)
Paint finish	
	Standard (green) 40 µm
Coil housing material	
ICO4D and ICO4N	Cast iron BS EN 1561:1997
ICO4S	Stainless steel BS 3146 ANC.4 BFC.316
Weight	
	Please contact us
Cv value at 10 bar (145 psi)	
1/4" model	0.8 (Kv 0.69)

Options

Port thread	
Solenoid valve	1/4" BSPP; 1/4" BSPT
Shuttle valve (female)	1/4" - 1/2" BSPP; 1/4" - 1/2" BSPT; 1/2" NPT
Port configuration	
	5/2
Valve material	
	Brass BS EN 12163: 1998
Seat / Seal material	
	Viton® Alternative materials available on request
Operating voltages (solenoid)	
	DC: 12, 24, 48, 110, 125, 240 AC: 24, 50, 110, 240, 440
Conduit / Signal entry	
	1/2" NPT, 13.5 PG
Paint	
	Epoxy (light grey) 150 µm
CV value at 10 bar (145 psi)	
1/2" model	3.2 (Kv 2.7)

Viton® is a registered trademark of DuPont Dow Elastomers LLC.



Maxseal
Dual Shuttle Valve for Hazardous Areas
EEx d, Ex N
Dual Shuttle Valve 1/4" - 1/2"

Technical Specification

Protection (solenoid)	Ingress IP65 / IP68 Surge suppression diodes
Response times (typical, dependent on coil size)	Pull-in: Please contact us Drop-out: Please contact us
Response times settings	Pull-in: within 87.5% of nominal (factory set at less than 75% of nominal) Drop-out: normally 10-20% of nominal

Dimensions in mm (inches)

(5/2 1/4" configuration illustrated)

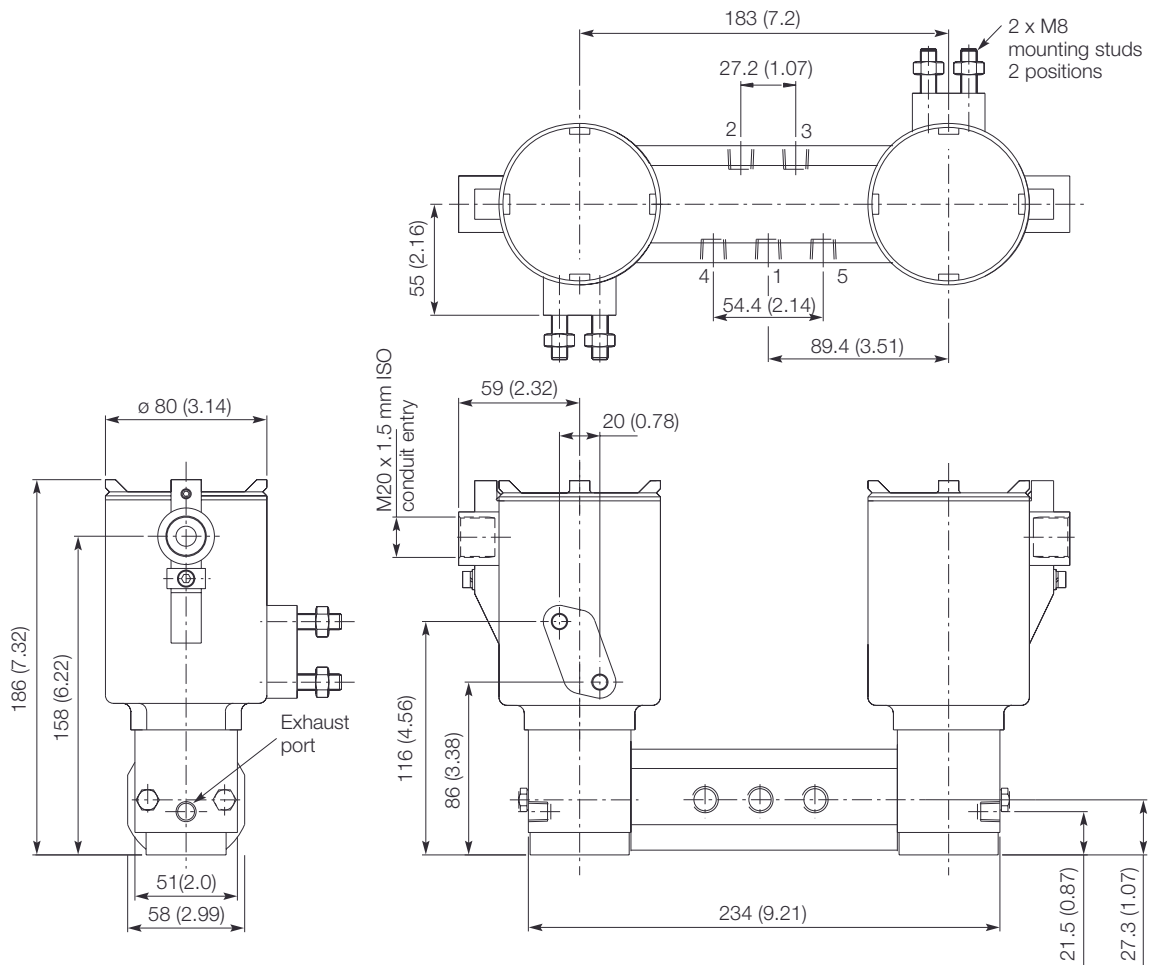

We recommend installing a strainer or filter as close as possible to valve inlet. While protecting seating areas from potential damage, this helps maintain **air quality** - Talk to us about filtration!

Maxseal Solenoid/Pilot-Operated Valve for Hazardous Areas Ex d, Ex N



Model POV 1/2" - 4"

Certification

Pilot operated valve optionally supplied with ICO4S, ICO4D or ICO4N. Refer to the relevant valves for certification data.

Description

A pilot-operated valve certified for hazardous area use as well as general liquid and gas purposes in the offshore and petrochemical industries.

Standard Features

Port thread	1/2" - 2" NPT
Port configuration	1/2" - 4" 2/2 EO, 2/2 EC 1/2" - 3" 3/2 1/2" - 2" 5/2
Operating pressure	Main valve 0 - 20 bar(g) (0 - 290 psi) Pilot valve 2 - 10 bar(g) (29 - 145 psi)
Actuation method	Solenoid-operated, external pilot liquid/gas assisted
Valve material	Stainless steel BS EN 10088
Seat / Seal material	High nitrile (Buna N)
Operating voltage	24V DC; 4.5W (ICO4D/S) at 20°C (68°F)
Conduit / Signal entry	M20 x 1.5 mm ISO (F)
Paint finish	Standard (green) 40 µm
Coil housing material	ICO4D and ICO4N Cast iron BS EN 1561:1997 ICO4S Stainless steel BS 3146 ANC.4 BFC.316
Weight	Please contact us
Cv value at 20 bar (290 psi)	1/2" model 3.2 (Kv 2.7) 3/4" model 6.8 (Kv 5.8) 1" model 12.8 (Kv 11) 1 1/2" model 28 (Kv 24) 2" model 48 (Kv 41) 3" model 100 (Kv 86) 4" model 165 (Kv 142)

5-port

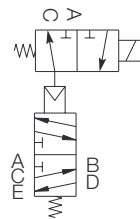

3-port

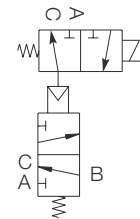

2-port, EO

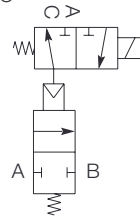

2-port, EC

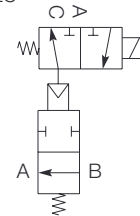

Options

Port thread (pilot body)	1/4" BSPP; 1/4" BSPT
Port connections	Female threaded 1/2" - 2" BSPP / BSPT Flanged 1/2" - 4" BS 10, BS 1504 or BS 4504
Valve material	Brass BS EN 12163: 1998
Seat / Seal material	Viton®, nylon 66 (high pressure seat only) Alternative materials available on request
Operating voltages	DC: 12, 24, 48, 110, 125, 240 AC: 24, 50, 110, 240, 440
Conduit / Signal entry	1/2" NPT, 13.5 PG
Paint	Epoxy (light grey) 150 µm
CV value	0 - 50 bar(g) (0 - 725 psi) 0 - 103/207 bar(g) (0 - 1494/3000 psi) Please contact us

Viton® is a registered trademark of DuPont Dow Elastomers LLC.

Maxseal
Solenoid / Pilot-Operated Valve for Hazardous Areas
EEx d, Ex N
POV 1/2" - 4"



Technical Specification

Protection	Ingress IP65 / IP68 Surge suppression diodes			
Response times	Pull-in: please contact us Drop-out: please contact us			
Response times settings	Pull-in: within 87.5% of nominal (factory set at less than 75% of nominal) Drop-out: normally 10-20% of nominal			
Operating pressure ranges				
Main valve	0 - 10 bar(g)	(0 - 145 psi)	2/2 port 1/2" - 4" 3/2 port 1/2" - 3" 5/2 port 1/2" - 2"	(option) (option) (option)
	0 - 20 bar(g)	(0 - 290 psi)	2/2 port 1/2" - 4" 3/2 port 1/2" - 3" 5/2 port 1/2" - 2"	(standard) (standard) (standard)
	0 - 50 bar(g)	(0 - 725 psi)	2/2 port 1/2" - 2" 3/2 port 1/2" to 1 1/2"	(option) (option)
	0 - 103 bar(g)	(0 - 1494 psi)	2/2 port 1/2" to 1 1/2" 3/2 port 1/2" to 1"	(option) (option)
	0 - 138 bar(g)	(0 - 2001 psi)	2/2 port 1/2" to 1 1/2" 3/2 port 1/2" - 1"	(option) (option)
	0 - 207 bar(g)	(0 - 3000 psi)	2/2 port 1/2" to 1 1/2" 3/2 port 1/2" - 1"	(option) (option)
Pilot signal	2 - 10 bar(g)	(29-145 psi)	2/2, 3/2 and 5/2 ports	

Dimensions in mm (inches)

(3/2 Uni 3/4" configuration illustrated)

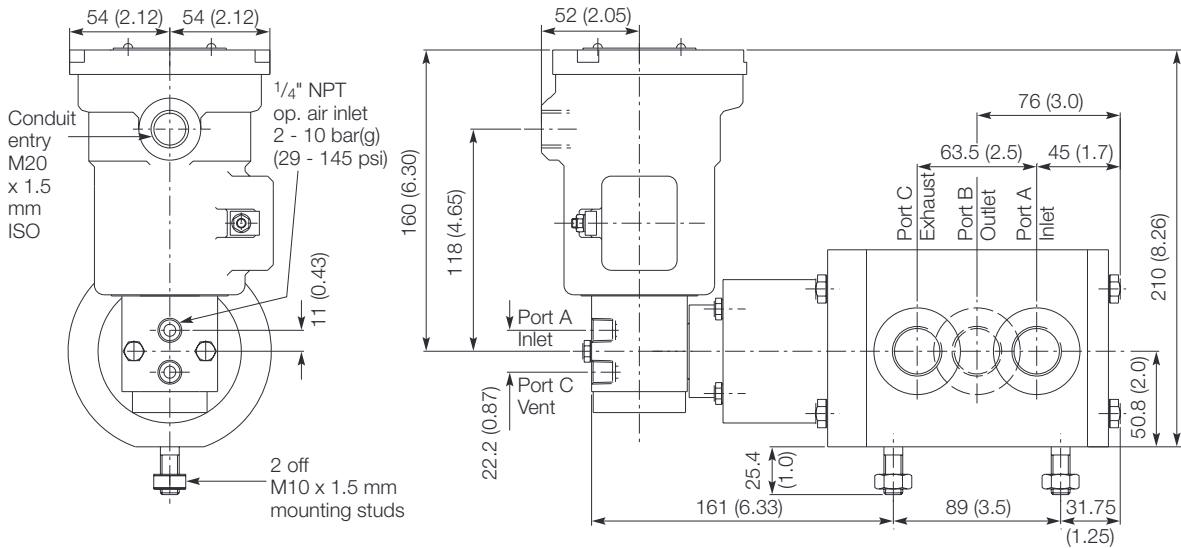

We recommend installing a strainer or filter as close as possible to valve inlet. While protecting seating areas from potential damage, this helps maintain **air quality** - Talk to us about filtration!

Maxseal Instrument Changeover and Process Control Valve for Hazardous Areas Ex N



Model ICO4N 1/4"

Certification

EECS (BASEEFA) approved
Ex N IIC T6
Ex N IIC T4 ($T_{amb} = 90^{\circ}\text{C}$)
Complies with BS 6941: 1988

Description

A direct-acting solenoid valve certified for hazardous area use as well as general air and gas purposes in the offshore and petrochemical industries.

3-port

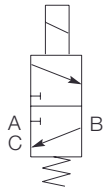

2-port, EO



2-port, EC



Standard Features

Port thread	1/4" NPT
Port configuration	3/2 Uni
Operating pressure	0 - 20 bar(g) (0 - 290 psi)
Actuation method	Automatic
Valve material	Brass BS EN 12163: 1998
Seat / Seal material	High nitrile (Buna N)
Operating voltage	24V DC; 7.8W at 20°C (68°F)
Conduit / Signal entry	M20 x 1.5 mm ISO (F)
Paint finish	Standard (green) 40 µm
Coil housing material	Cast iron BS EN 1561: 1997
Weight	3-port version: 3.5 kg (7.7 lb)
Cv value	0.8 (Kv 0.69)

Options

Port thread	1/4" BSPP; 1/4" BSPT
Port configuration	2/2 EO; 2/2 EC
Actuation method	Autolatch, lever manual reset (LMR), lever manual override (LMO), tamperproof manual reset (see "Optional Valve Features")
Valve material	Stainless steel BS EN 10088
Seat / Seal material	Viton®, Alternative materials available on request
Operating voltages	DC: 12, 24, 50, 110, 125, 240 AC: 24, 50, 110, 240, 440
Conduit / Signal entry	1/2" NPT, 13.5 PG
Paint	Epoxy (light grey) 150 µm
CV value	0 - 50 bar(g) (0 - 725 psi) = 0.6 (Kv = 0.5)

Viton® is a registered trademark of DuPont Dow Elastomers LLC.



Maxseal
Instrument Changeover and Process Control Valve for Hazardous Areas
Ex N
ICO4N 1/4"

Technical Specification

Protection	Ingress IP65 - IP68 Surge suppression diodes
Response times (typical, dependent on coil size)	Pull-in < 150 ms Drop-out < 80 ms
Response times settings	Pull-in: within 87.5% of nominal (factory set at less than 75% of nominal) Drop-out: normally 10-20% of nominal
Operating pressure ranges	0 - 20 bar(g) (0 - 290 psi) (standard) 0 - 50 bar(g) (0 - 725 psi) (option)

Dimensions in mm (inches)

(3/2 Uni configuration illustrated)

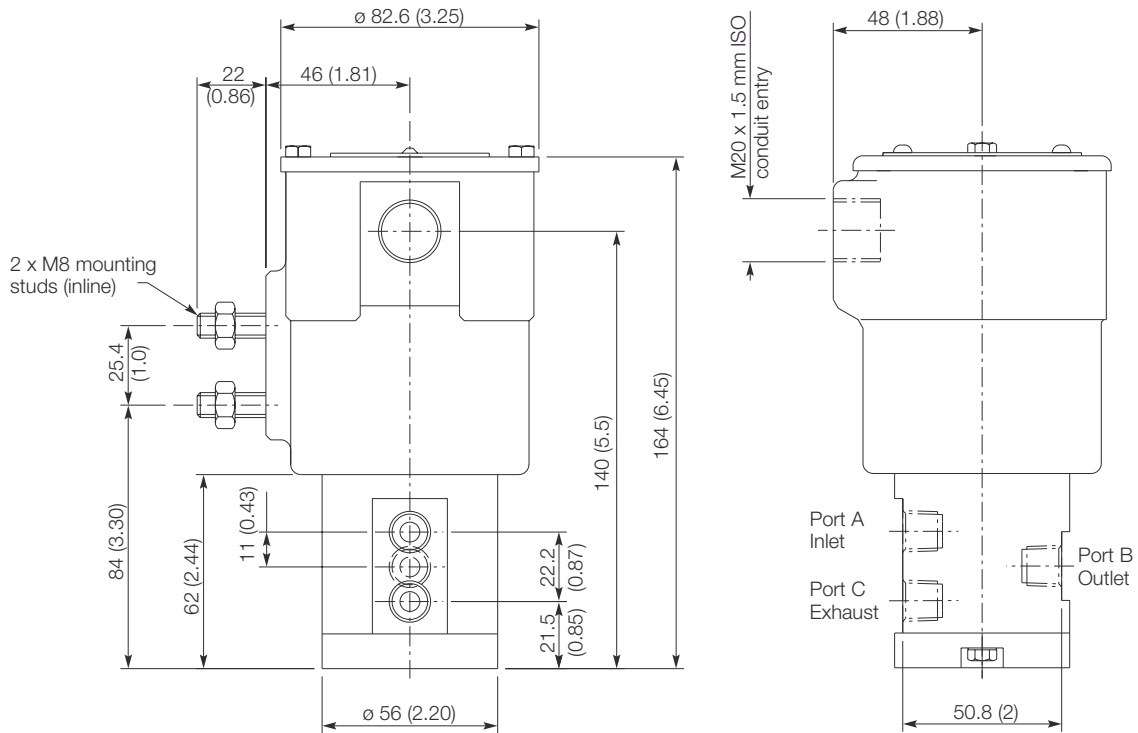

i Remember that overhaul kits and replacement coil housing assemblies are available.

Maxseal Direct Solenoid-Operated Control Valve for Hazardous Areas Ex es



Model SOV, Sizes 1, 2, 3, 4, 5 & 6 (1" - 4")

Certification

EECS (BASEEFA)
approved
Ex es II T6 or Ex es II T4
(ambient = 85°C)
Complies with BS 5501:
Part 6:1977

Description

A direct-acting solenoid valve certified for hazardous area use as well as general air and gas purposes in the offshore and petrochemical industries.

Standard Features

Port thread	1" - 2" NPT
Port configuration	3/2 Uni
Operating pressure	0 - 20 bar(g) (0 - 290 psi)
Actuation method	Automatic
Valve material	Stainless steel BS EN 10088
Seat / Seal material	High nitrile (Buna N)
Operating voltage at 20°C (68°F)	
Size 1	24V DC; 18W
Size 2	24V DC; 25W
Size 3	24V DC; 40W
Size 4	24V DC; 75W
Size 5	24V DC; 100W
Size 6	24V DC; 150W
Conduit / Signal entry	M20 x 1.5 mm ISO (F)
Paint finish	Standard (green) 40 µm
Coil housing material	Cast iron BS EN 1561: 1997
Weight (approx.)	
Size 1	20 kg (44 lb)
Size 2	30 kg (66 lb)
Size 3	35 kg (77 lb)
Size 4	58 kg (128 lb)
Size 5	65 kg (144 lb)
Size 6	115 kg (254 lb)
Cv value at 20 bar (290 psi)	
1" model	12.8 (Kv 11)
1½" model	28 (Kv 24)
2" model	48 (Kv 41)
2½" model	70 (Kv 60)
3" model	100 (Kv 86)
4" model	165 (Kv 142)

5-port

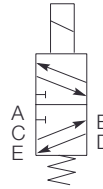

3-port

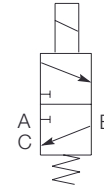

2-port, EO



2-port, EC



Options

Port connections	
Female threaded	1" - 2" BSPP / BSPT
Flanged	1" - 4" BS 10, BS 1560 or BS 4504
Port configuration	5/2 Uni; 2/2 EO; 2/2 EC
Actuation method	Autolatch, lever manual reset (LMR), lever manual override (LMO), tamperproof manual reset (see "Optional Valve Features")
Valve material	Brass BS EN 12163: 1998 Flanged/cast bodies available on request
Seat / Seal material	Viton®, nylon 66 (high pressure seat only) Alternative materials available on request
Operating voltages	DC: 12, 24, 48, 110, 125, 240 AC: 24, 50, 110, 240, 440
Conduit / Signal entry	½" NPT, 13.5 PG
Paint	Epoxy (light grey) 150 µm
CV value	50 bar(g) (725 psi) + Please contact us



Maxseal
Direct Solenoid-Operated Control Valve for Hazardous Areas
Ex es
SOV, Sizes 1, 2, 3, 4, 5 & 6 (1" - 4")

Technical Specification

Protection	Ingress IP65 - IP68 Surge suppression diodes
Response times (typical, dependent on coil size)	Pull-in: Please contact us Drop-out: Please contact us
Response times settings	Pull-in: within 87.5% of nominal (factory set at less than 75% of nominal) Drop-out: normally 10-20% of nominal
Operating pressure ranges	0 - 20 bar(g) (0 - 290 psi) (standard) 0 - 50 bar(g) (0 - 725 psi) bar stock body (option) 0 - 103 bar(g) (0 - 1494 psi) bar stock body (option) 0 - 207 bar(g) (0 - 3000 psi) bar stock body (option)

Dimensions in mm (inches)

(Size 2 3/4" solenoid 3/2 Uni configuration illustrated)

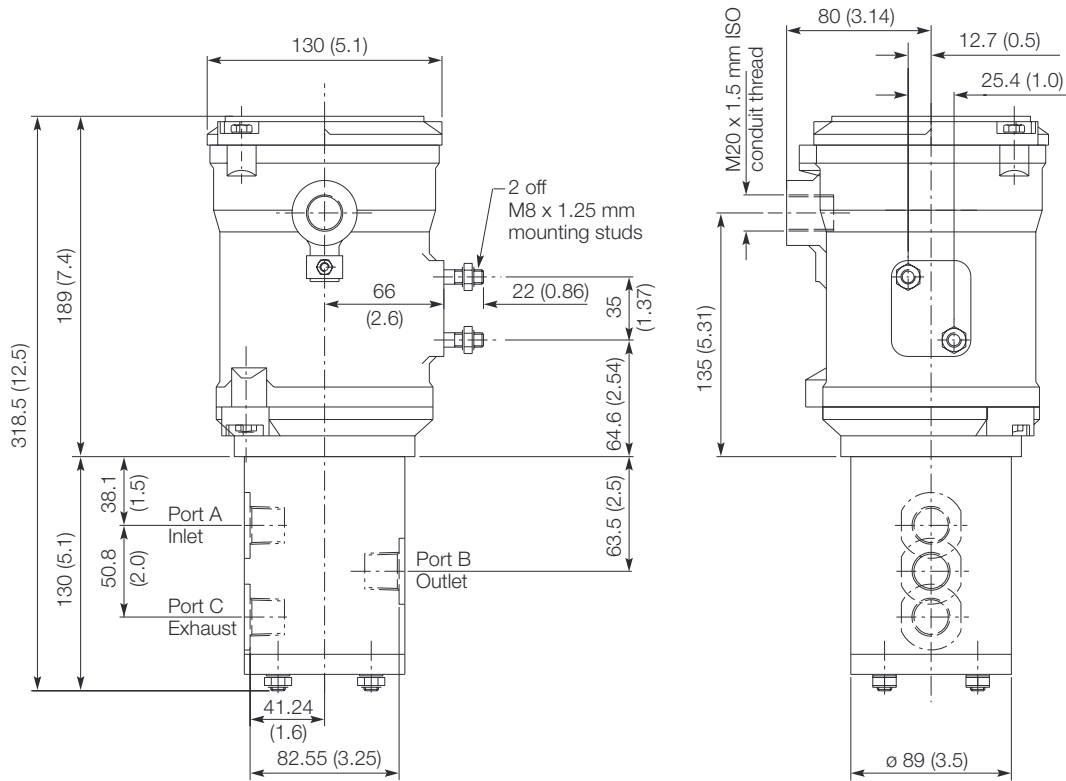

We recommend installing a strainer or filter as close as possible to valve inlet. While protecting seating areas from potential damage, this helps maintain **air quality** - Talk to us about filtration!

Viton® is a registered trademark of DuPont Dow Elastomers LLC.

Maxseal Air Operated Valve



Model AOV 1/4"

Description

A general purpose direct-acting valve for liquid and gas management in industrial applications.

5-port

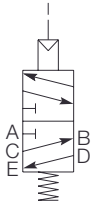

3-port

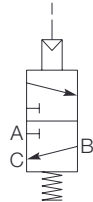

2-port, EO

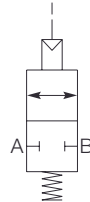

2-port, EC

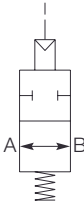

Standard Features

Port thread	1/4" NPT
Port configuration	3/2 Uni
Operating pressure	
Main valve	0 - 20 bar(g) (0 - 290 psi)
Pilot signal	2 - 10 bar(g) (29 - 145 psi)
Actuation method	Liquid/gas operated
Valve material	Brass BS EN 12163: 1998
Seat / Seal material	High nitrile (Buna N)
Paint finish	Standard (green) 40 µm
Weight	3-port version: 2 kg (4.4 lb)
Cv value	0.8 (Kv 0.69)

Options

Port thread	1/4" BSPP; 1/4" BSPT
Port configuration	5/2, 2/2 EO; 2/2 EC
Valve material	Stainless steel BS EN 10088
Seat / Seal material	Viton® Alternative materials available on request
Paint	Epoxy (light grey) 150 µm
CV value	0 - 50 bar(g) (0 - 725 psi) = 0.6 (Kv = 0.5) 0 - 103/207 bar(g) (0- 1494/3000 psi) = 0.28 (kv = 0.24)

Viton® is a registered trademark of DuPont Dow Elastomers LLC.



**Maxseal
Air Operated Valve**

AOV 1/4"

Technical Specification

Response times	60 - 100 ms		
Operating pressure ranges			
Main valve	0 - 20 bar(g) Up to 207 bar(g)	(0 - 290 psi) (3000 psi)	2/2 and 3/2 ports 2/2 and 3/2 ports
Pilot signal	0 - 20 bar(g) 2 - 10 bar(g)	(0 - 290 psi) (29 - 145 psi)	5/2 port 2/2, 3/2 and 5/2 ports

Dimensions in mm (inches)

(3/2 Uni configuration illustrated)

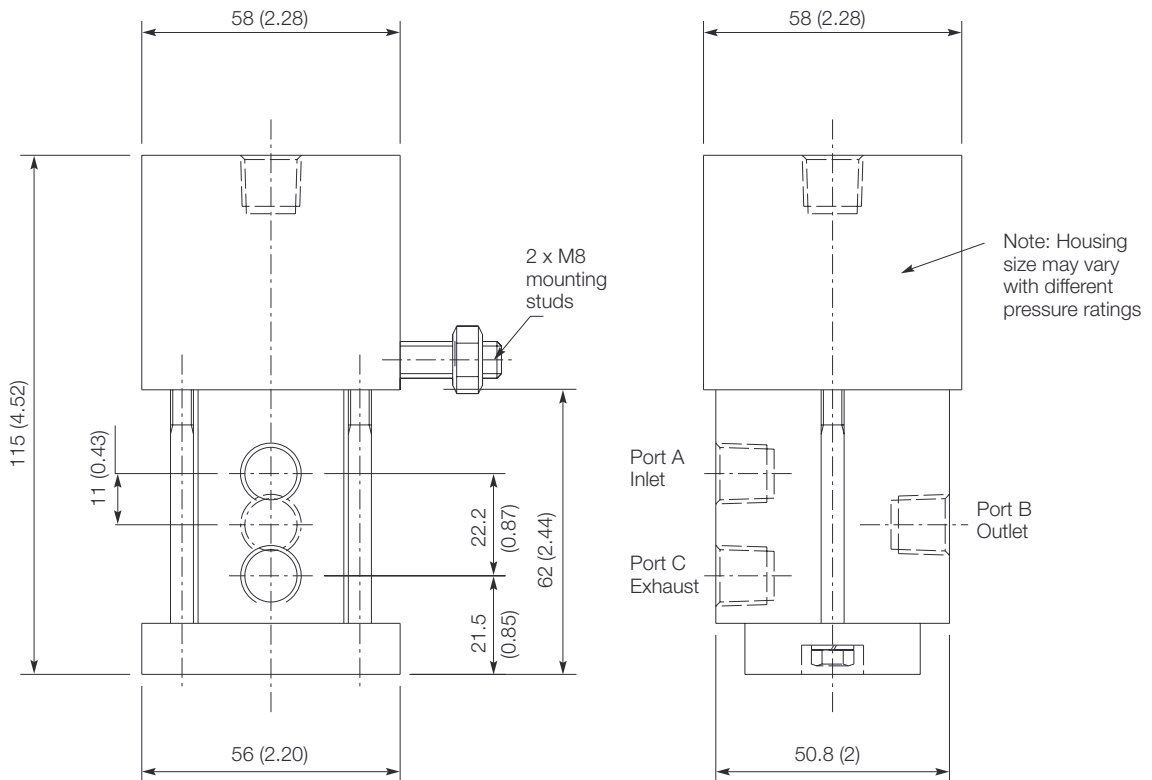

i For your convenience, Operation and Maintenance instructions are included with each valve.

Maxseal Air Operated Valve



Model AOV 1/2" - 4"

Description

A general purpose direct-acting valve for liquid and gas management in industrial applications.

5-port

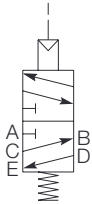

3-port

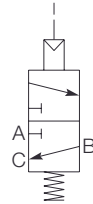

2-port, EO

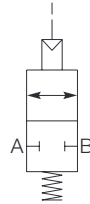

2-port, EC

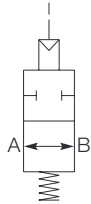

Standard Features

Port thread	1/2" - 2" NPT
Port configuration	1/2" - 4" 2/2 EO, 2/2 EC 1/2" - 3" 3/2 1/2" - 2" 5/2
Operating pressure	Main valve 0 - 20 bar(g) (0 - 290 psi) Pilot signal 2 - 10 bar(g) (29 - 145 psi)
Actuation method	Air operated, external pilot liquid/gas assisted
Valve material	Brass BS EN 12163: 1998
Seat / Seal material	High nitrile (Buna N)
Paint finish	Standard (green) 40 µm
Weight	Please contact us
Cv value	Please contact us

Options

Port thread	1/2" BSPP; 1/2" BSPT
Port connections	Female threaded 1/2" - 2" BSPP / BSPT Flanged 1/2" - 4" BS 10, BS 1504 or BS 4504
Valve material	Stainless steel BS EN 10088
Seat / Seal material	Viton® Alternative materials available on request
Paint	Epoxy (light grey) 150 µm
CV value	Please contact us

Viton® is a registered trademark of DuPont Dow Elastomers LLC.



**Maxseal
Air Operated Valve**

AOV 1/2" - 4"

Technical Specification

Response times	60 - 100 ms			
Operating pressure ranges				
Main valve	0 - 10 bar(g)	(0 - 145 psi)	2/2 port 1/2" - 4" 3/2 port 1/2" - 3" 5/2 port 1/2" - 2"	(option) (option) (option)
	0 - 20 bar(g)	(0 - 290 psi)	2/2 port 1/2" - 4" 3/2 port 1/2" - 3" 5/2 port 1/2" - 2"	(standard) (standard) (standard)
	0 - 50 bar(g)	(0 - 725 psi)	2/2 port 1/2" to 2" 3/2 port 1/2" to 1 1/2"	(option) (option)
	0 - 103 bar(g)	(0 - 1494 psi)	2/2 port 1/2" to 1 1/2" 3/2 port 1/2" to 1"	(option) (option)
	0 - 138 bar(g)	(0 - 2001 psi)	2/2 port 1/2" - 1 1/2" 3/2 port 1/2" to 1"	(option) (option)
	0 - 207 bar(g)	(0 - 3000 psi)	2/2 port 1/2" - 1 1/2" 3/2 port 1/2" - 1"	(option) (option)
Pilot signal	2 - 10 bar(g)	(29-145 psi)	2/2, 3/2 and 5/2 ports	

Dimensions in mm (inches)

(2/2 EO 4" configuration illustrated)

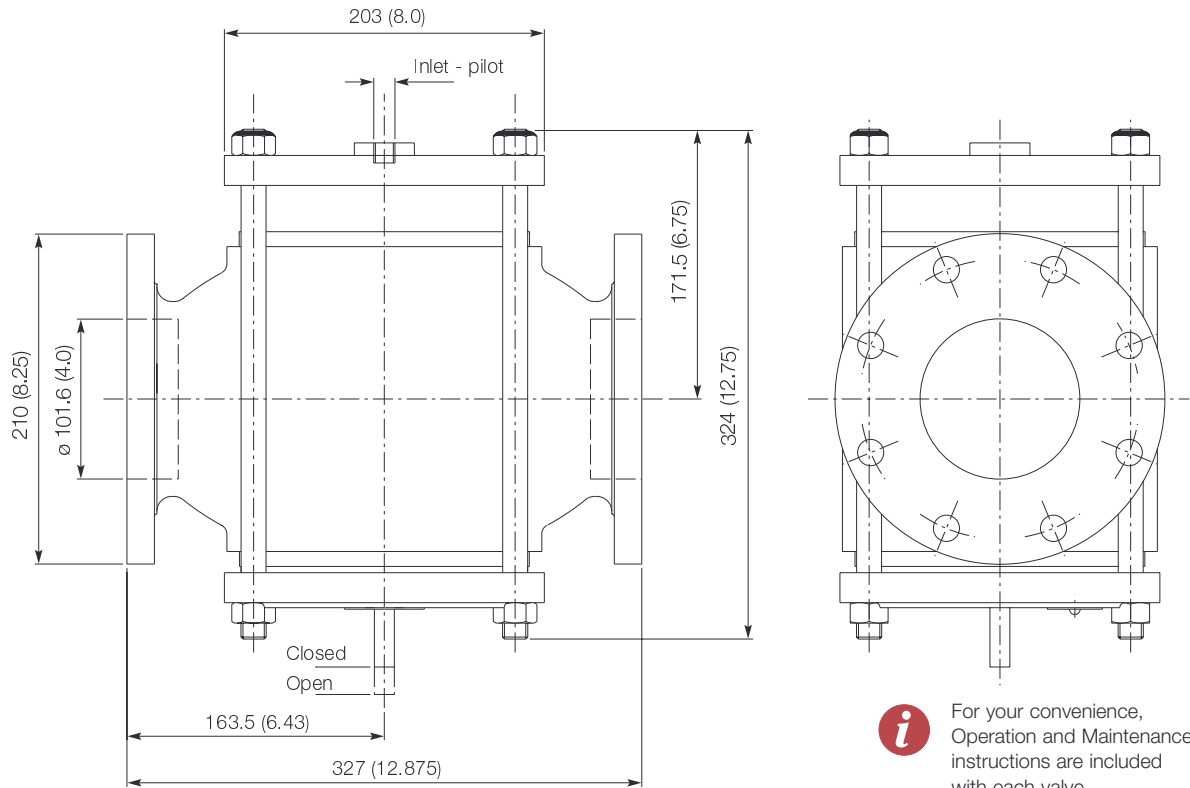

Maxseal Solenoid Valves.

Optional Valve Features.



Automatic (Standard).

An electrical and/or air/gas supply energizes the valve, opening, closing or changing over valve ports, depending on model and porting configuration. When the valve is de-energized, it is spring-returned to its original position.

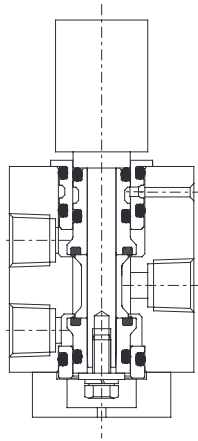

Automatic Latching Lever.

When the solenoid is energized, the lever (standard) drops and latches the valve in the energized position. On loss of electrical supply, it remains latched until manually unlatched.

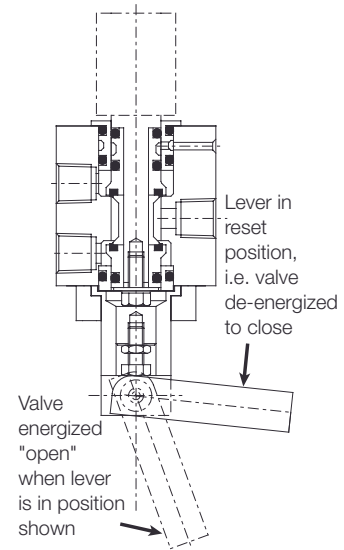

Lever Manual Reset.

After the valve operator is energized, the manual reset lever (or button) must be operated to move the valve to the energized position. When the valve is de-energized, it is spring-returned to its original position.

Lever option:
ICO4 and SOV.
Button option:
ICO2 and ICO4.

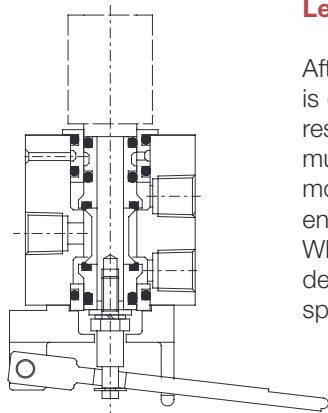

Tamperproof Manual Reset.

Models ICO2 and ICO4 3-port only.

- When de-energized and with air on inlet port (A), the valve will not change-over, even when the reset button is pressed.
- When the coil is energized and the reset button pressed, the reset button lifts the spool assembly into the magnetic field of the coil, thereby holding the spool assembly in the energized position.
- No air will flow through the valve until the reset button is released.
- In the energized position, air flows from inlet port (A), via the "gallery drilling", through the valve body and out through outlet port (B). At this point, exhaust port (C) is isolated.
- When the coil is de-energized, the spool assembly is spring-returned to the de-energized position, isolating inlet port (A) and venting air from outlet port (B) to exhaust port (C).
- If the push button is held, jammed or wire-locked in the depressed position, the air inlet supply remains isolated.

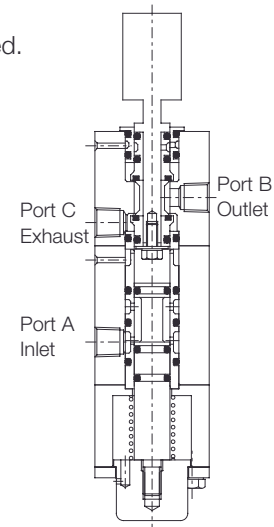

Lever Manual Override.

A jackscrew or lever (as shown) fitted to the base of the valve moves it to the energized or de-energized position without electrical power.

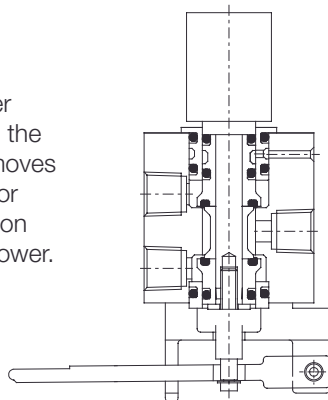

Special Valve Features.

Indicating Switches.



Micro-switches, available on models SOV, AOV and POV only, indicate valve open and closed positions (2 x spdt standard). They can be fitted inside the coil housing (SOV) or to the base of the main valve (AOV and POV), and are electrically certified for the hazardous area required.

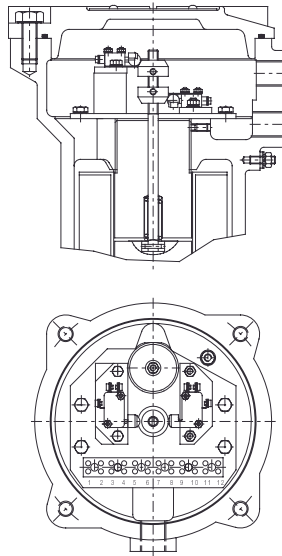

High Temperature Spacer.

Available on models ICO4 and SOV direct-acting solenoid valves only, high-temperature spacers are fitted between coil housing and valve assembly where media temperature exceeds 80°C (176°F). This feature dissipates heat away from the coil housing, preventing overheating of the coil itself.

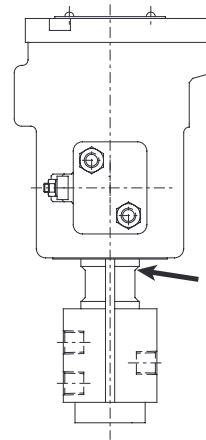

Horizontal Mounting.

For SOV direct-acting solenoid valves only, this feature is used on valves requiring the coil housing to be installed horizontally. It prevents excessive wear of dynamic seals within the valve body.

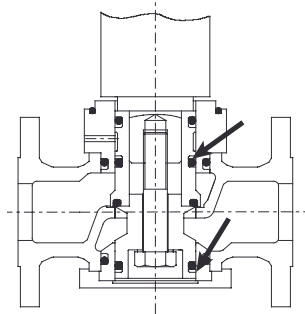

We are here to help!
Remember that complete spares kits are available.

Intrinsic Safety.

This type of protection is based on the minimum energy needed to ignite a hazardous atmosphere. The risk of ignition can be avoided by designing the whole circuit in such a way that this energy is never available, either under normal operating conditions or under specific fault conditions.

Unlike other types of protection which apply to single electrical devices, “intrinsic safety” applies to *the whole electrical circuit*. Intrinsic safety implies:

- limiting peak current and voltage at open circuit conditions,
- limiting thermal and electrical energy storage.

An intrinsically safe electrical device such as a solenoid valve must be installed together with a safety device which limits the available power (energy) to specific values.

Typical Intrinsically Safe Circuit.

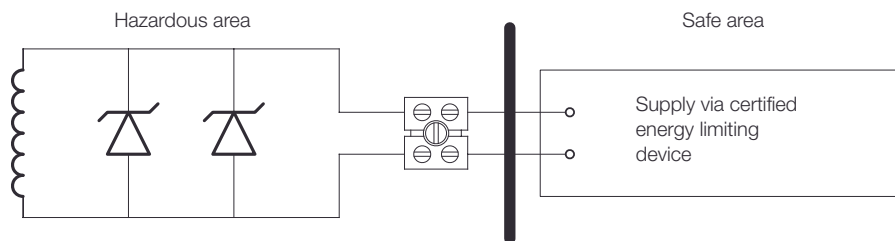

PHOTOGRAPH COURTESY OF SHELL

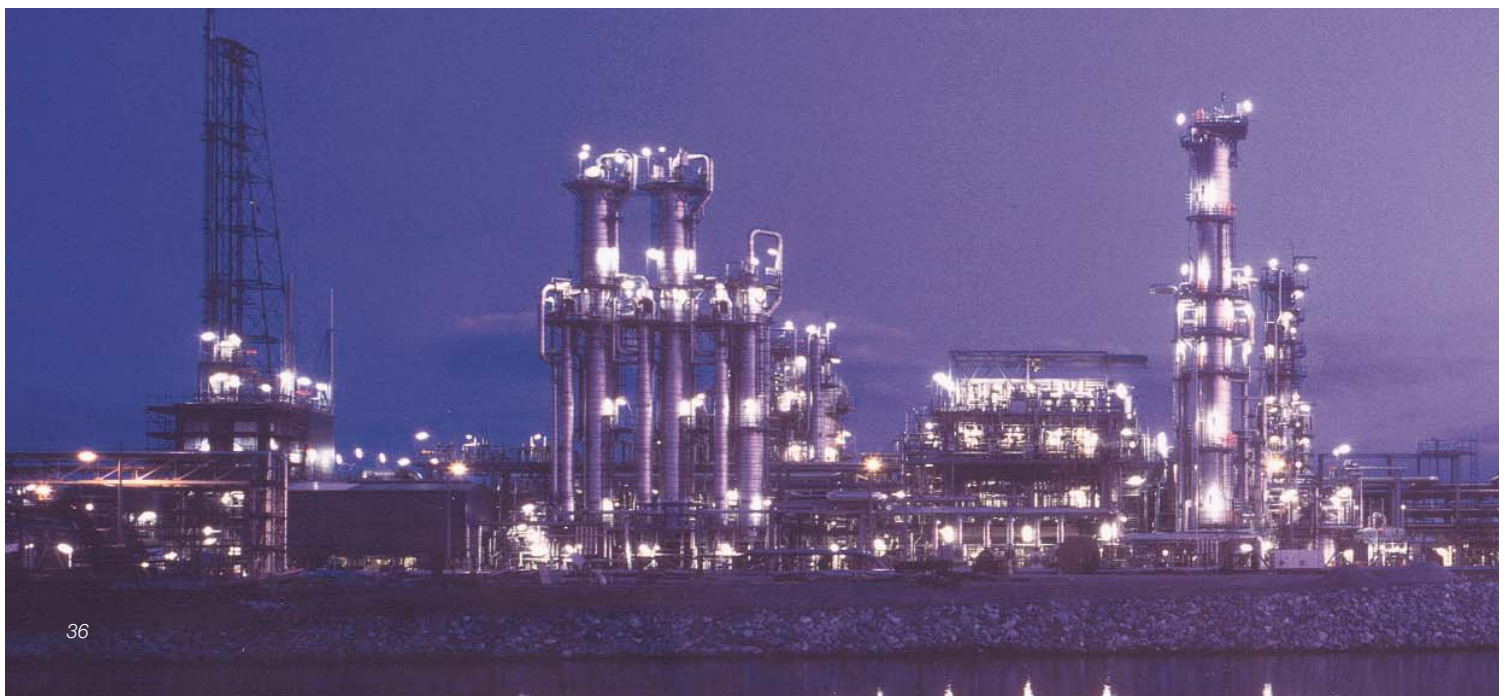

Hazardous Area Installation Guidelines.

A simplified appreciation of hazardous area types and risk levels involved.



The ultimate decision as to what constitutes a hazardous area (or zone) rests with the company chemist, usually in consultation with health and safety executives or an authorizing body. The role of the instrument or

design engineer is to ensure that emergency shutdown apparatus (ESD), e.g. Maxseal solenoid valves, complies with operating speed and zoning requirements.

Most countries or trade areas have their own certifying authorities. Hazardous area installation standards in force in the EU are written by CENELEC¹/IEC². They can be certified by any

recognized authorizing body, such as BASEEFA in the UK, and enjoy wide global acceptance, except in the USA and dollar areas where American standards prevail.

¹ International Electrotechnical Commission ² European Committee for Electrotechnical Standards.

Current CENELEC/IEC Hazardous Area Classification.

An open area of plant or factory is considered hazardous when a fire or explosion may result from specific potential conditions. Three zones are defined:

Zone 0
(Category 1 from 2003 as per the ATEX directive)
“An area in which a hazardous or gas/air mixture is continuously present or present for long periods.”

Zone 1
(Category 2 from 2003 as per the ATEX directive)
“An area in which a hazardous gas/air mixture is likely to occur in normal operation.”

Zone 2
(Category 3 from 2003 as per the ATEX directive)
“An area where a hazardous gas/air mixture is unlikely to occur under normal operation, but if it occurred it would only be for a short duration.”

Both the risk level and zoning definition are affected by ventilation, quantity and type of gas (heavier/lighter than air), as well as the need for a heat source to prompt ignition.



Solenoids should be selected according to the standard identification code for hazardous area equipment.

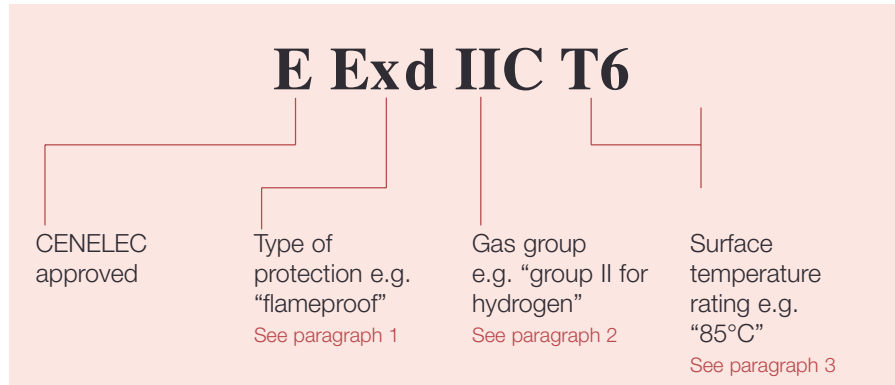

1. Protection Methods in Hazardous Areas.

Type	Symbol	Zone	Comments
Flameproof	'd'	1 ³ & 2	Relies on containment of any explosion inside the coil housing
Intrinsic safety	'ia'	0	Low power technique. Insignificant energy to create an explosion. (permits two failure conditions)
Increased safety	'e'	1 & 2	Relies on design criteria
Non-incendive	'N'	2	Relies on design criteria

³ Theoretical. Little precedent for use in Zone 1.

Other protection methods such as oil immersion ('o') or powder filling ('q') are usually associated with products other than solenoid valves.

2. Apparatus or Gas Groups.

There are 2 main gas groups:

Group I relates specifically to mining applications.

Group II applies to all applications other than mining and is subdivided into:

- Group IIA** - Propane
- Group IIB** - Ethylene
- Group IIC** - Hydrogen

Group IIA includes the least incendive gases and IIC the most incendive. For standardization and safety reasons, valve manufacturers usually fit solenoids certified for group IIC gases.

It should be noted that American incendivity groups go in reverse, A being the most incendive and D the least.

PHOTOGRAPH COURTESY OF BAE SYSTEMS MARINE LIMITED



i We are here to help!
Protect your system with a relief valve.

3. Surface Temperature.

Most gases will not ignite without a heat source. This could be any heated object, not necessarily a naked flame, approaching the gas flash point.

Hazardous area equipment is therefore designed to limit surface temperature in continuous or intermittent operation, so as to minimize the risk of ignition of surrounding gases.

⁴ 'G' in Germany.

⁵ Based on an ambient of 40°C (104°F).

Apparatus Temperature Classification

Class	Maximum Surface Temperature (°C/°F) ⁵
T1	450°C/842°F
T2	300°C/572°F
T3	200°C/392°F
T4	135°C/275°F
T5	100°C/212°F
T6	85°C/185°F

Maxseal solenoid valves can be installed in ambient temperatures of up to 90°C (194°F) while still retaining a T4 rating.

General Note.

Hazardous areas standards for dust and fibres (zones 10 and 11) are not covered here, nor are the USA standards. Please contact FC^x Thompson Valves regarding these types of hazardous areas, and any other matter where installation guidance or valve selection information is needed.



PHOTOGRAPH COURTESY OF SHELL

Maxseal Solenoid Valves.

Valve Flow Characteristics.



Table 1
Flow Coefficients

Valve Type Nominal Size		Flow Path	Maximum Pressure	Valve Flow Coefficients				
(")	(mm)			C Conductance (l/s/ bar abs)	B Critical Pressure Ratio	C_v (USgpm for 1 psi Δp)	K_v (l/min for 1 bar Δp)	K_v (m ³ /hr for 1 bar Δp)
1/4	6	Any	20	3.7	0.32	0.8	11.5	0.69
3/8	10	Any	20	10	0.33	1.7	24.5	1.46
1/2	15	Any	20	15	0.35	3.2	46	2.75
3/4	20	Any	20	27	0.35	6.8	98	5.84
1	25	Any	20	50	0.36	12.8	184	11
1 1/4	32	Any	20	70	0.38	18	259	15.5
1 1/2	40	Any	20	106	0.39	28	403	24
2	50	Any	20	190	0.39	48	691	41.2
2 1/2	60	Any	20	270	0.4	70	1008	60.2
3	75	Any	20	380	0.4	100	1440	86
4	100	Any	20	630	0.4	165	2376	141.9

Table 2
Media Characteristics - Gases

Medium	Symbol	Density Relative to Air (G)	Actual Density (kg/m ³)
Air	N ₂ + O ₂	1.0	1.2
Hydrogen	H ₂	0.068	0.082
Nitrogen	N ₂	0.96	1.15
Oxygen	O ₂	1.10	1.32
Helium	He	0.138	0.166
Argon	A	1.38	1.66
Neon	Ne	0.69	0.83
Krypton	Kr	2.90	3.48
Xenon	Xe	4.55	5.46
Carbon dioxide	CO ₂	1.52	1.824
Carbon monoxide	CO	0.96	1.15
Ammonia	NH ₃	0.59	0.71
Methane	CH ₄	0.55	0.67

Density figures at 293°K and 1.018 bar (14.7 psi).

Table 3
Media Characteristics - Liquids

Medium	Symbol	Mass Density (kg/l)
Water	H ₂ O	1.0
Heavy water	D ₂ O	1.1
Shell Tellus T15	-	0.86
Olive oil	-	0.9
Ethanol	C ₂ H ₅ OH	0.8

We are here to help!
www.fcx-thompson-valves.com

Glossary of Terms.

Conductance (C) The conductance is a constant value that is the ratio of airflow across the valve to inlet pressure p_1 at choked flow conditions.

Critical Pressure Ratio (B) The critical pressure ratio of a pneumatic component is the ratio of outlet pressure to inlet pressure where choked flow is reached.

K_v The K_v value for a valve is the flow rate of water through the valve in l/min or in m³/hr when the Δp across the valve is 1 bar.

C_v The C_v value for a valve is the flow rate of water through the valve in USgpm for a 1 psi Δp .

Liquid Flow.

The flow rate of a liquid through a valve is given by:

$$Q = K_v \cdot \sqrt{\frac{\Delta p}{\gamma}}$$

Where:

Q = Flow rate l/min

γ = Mass density in kg/l at process temperature and pressure (water @ 20°C = 1 kg/l)

$\Delta p = p_1 - p_2$

p_1 = inlet pressure in bar abs.

p_2 = outlet pressure in bar abs.

K_v = Flow rate of water through the valve in l/min when Δp across the valve is 1 bar. For comparison and conversion purposes, the C_v (USgpm for 1 psi) and K_v (m^3/hr for 1 bar) are also given in Table 1.

Gas Flow.

The following modes of calculation are based on BS 7294:1990; ISO 6358:1989.

1. For non-choked flow (low flow conditions i.e. $p_2/p_1 > B$)

$$Q = \frac{C \cdot p_1}{\sqrt{G}} \cdot \sqrt{\frac{T_0}{T_1}} \cdot \sqrt{1 - \left[\frac{\frac{p_2}{p_1} - B}{1 - B} \right]^2}$$

Where:

Q = Flow rate in normal (N) l/s

C = Conductance in l/s/bar abs. See Table 1.

B = Critical pressure ratio. See Table 1.

p = Pressure in bar abs.

p_1 = inlet pressure in bar abs.

p_2 = outlet pressure in bar abs.

G = Specific gravity relative to air.

T = Temperature.

$T_0 = 293^\circ K$

$T_1 =$ Upstream temperature $^\circ K$

2. For choked flow (high flow conditions i.e. $p_2/p_1 < B$)

$$Q = \frac{C \cdot p_1}{\sqrt{G}} \cdot \sqrt{\frac{T_0}{T_1}}$$

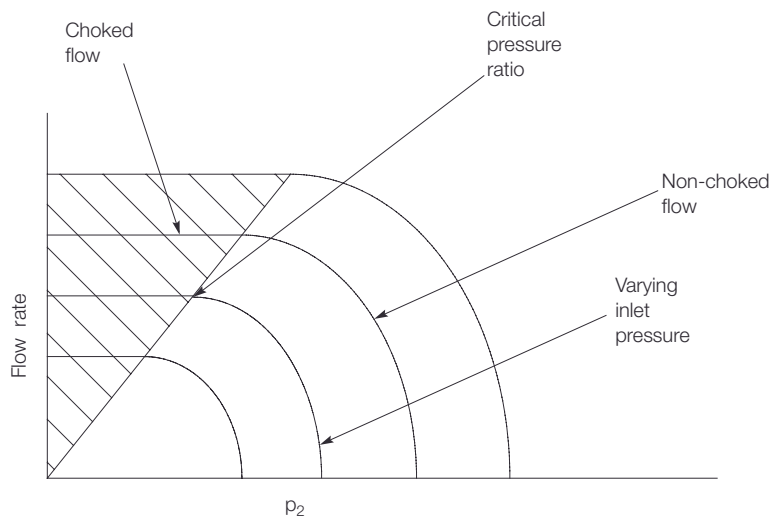

We are here to help!

When you've browsed this overview, talk to us about the best solution for your system.

Maxseal Solenoid Valves. Valve Flow Characteristics.



Example Gas Flow Calculations.

Non-choked flow.

What is the maximum flow of methane through a 1" SOV with an inlet pressure of 15 bar and a pressure drop of 7 bar?

Is the flow choked?

For choked flow, $p_2/p_1 = 0.36$ (critical pressure ratio). p_2 , the outlet pressure, is equal to 9 bar abs (16 - 7 bar) and p_1 , the inlet pressure, is equal to 16 bar abs (1 + 15 bar).

As $p_2/p_1 = 0.56$, the flow is choked.

Determine flow

Using Table 1, conductance C for 1" valve = 50 l/s/bar abs

And, from Table 2, specific gravity of methane relative to air is 0.55

Therefore

$$Q = \frac{C \cdot p_1}{\sqrt{G}} \sqrt{1 - \left[\frac{\frac{p_2}{p_1} - B}{1 - B} \right]^2} = \frac{50 \times 16}{\sqrt{0.55}} \sqrt{1 - \left[\frac{\frac{9}{16} - 0.36}{1 - 0.36} \right]^2} = 1022 \text{ l/s}$$

Choked flow.

What is the maximum flow of air (to atmosphere) through a 1/4" ICO4 valve with an inlet pressure of 4.5 bar?

Is the flow choked?

For choked flow, $p_2/p_1 = 0.32$ (critical pressure ratio). p_2 , the ambient air pressure, is equal to 1 bar abs and p_1 , the inlet pressure, is equal to 5.5 bar abs (1 + 4.5 bar).

As $p_2/p_1 = 0.18$, the flow is choked.

Determine flow

Using Table 1, conductance C for 1/4" valve = 3.7 l/s/bar abs

Therefore

$$Q = C \cdot p_1 = 3.7 \times 5.5 = 20.4 \text{ l/s}$$



We are here to help!
Filters contribute to longer system life.

Valve Flow Performance.

Chart 1.

Air Flow, ICO4 1/4", Low Pressure

20 bar max., universal

$C = 3.7$, $B = 0.3$, $C_v = 0.8$ USgpm

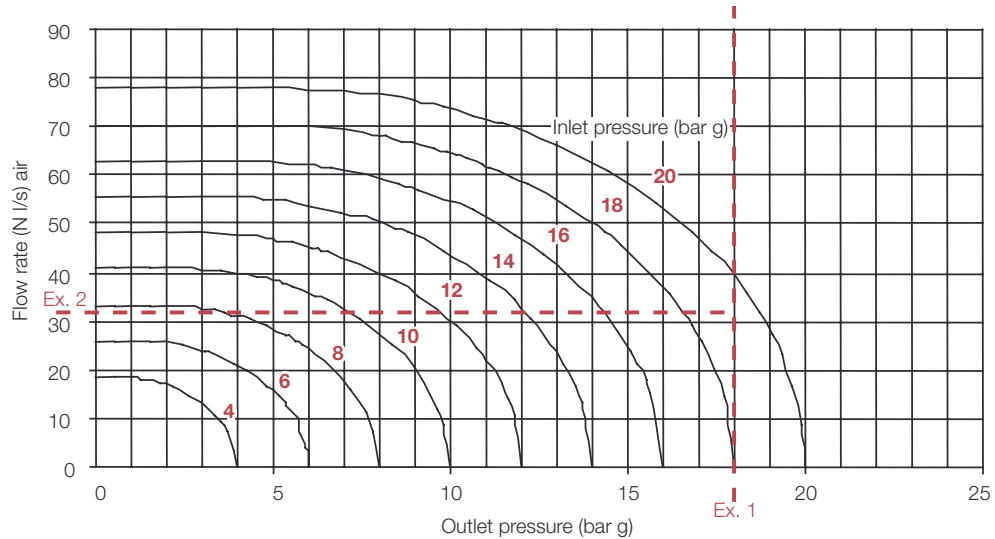

Example 1: What is the flow rate at 20 bar inlet and 18 bar outlet pressures (i.e. 2 bar Δp)?

Answer: 40 N l/s.

Example 2: What is the Δp at inlet 10 bar and 32 l/s flow?

Answer: $10 - 7 = 3$ bar.

Chart 2.

Air Flow, ICO4 1/2", Low Pressure

20 bar max., universal

$C = 15$, $B = 0.35$, $C_v = 4.2$ USgpm

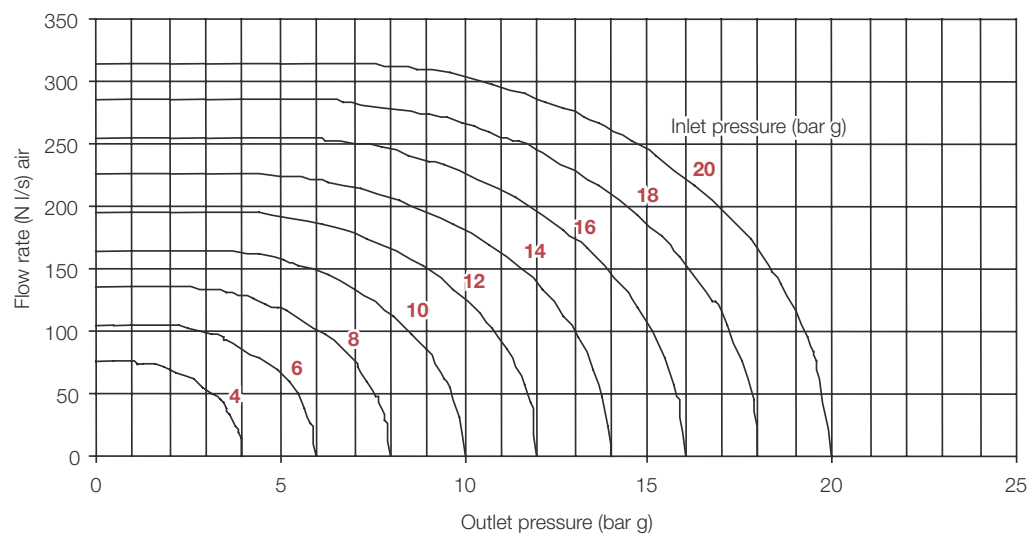

Maxseal Solenoid Valves. Valve Flow Performance.



Chart 3.
Liquid Flow, ICO4 1/4", Low Pressure
 20 bar max., $C_v = 0.8$ USgpm
 Fluid water at density 1 kg/l

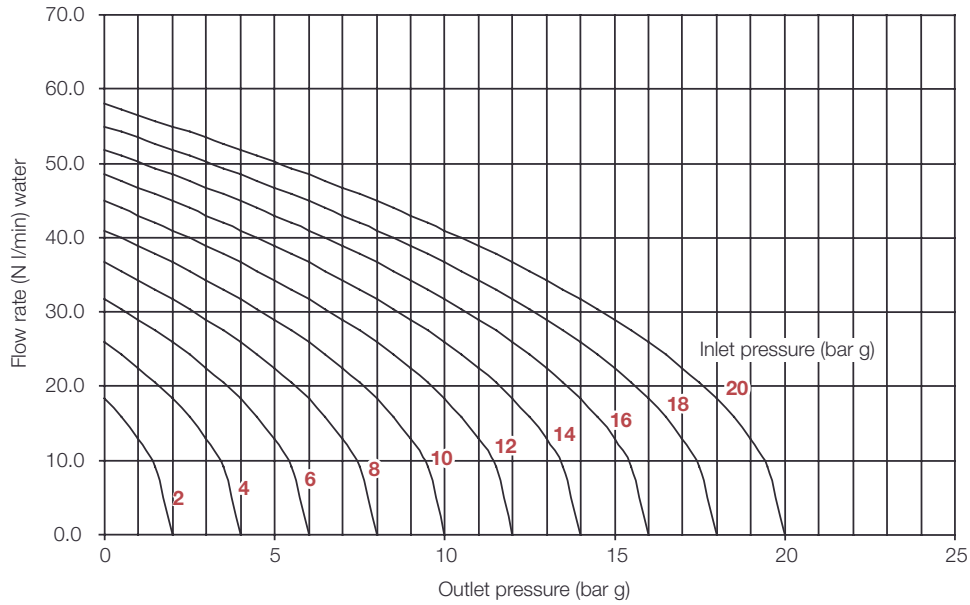

Chart 4.
Liquid Flow, ICO4 1/4", High Pressure
 207 bar max., $C_v = 0.28$ USgpm

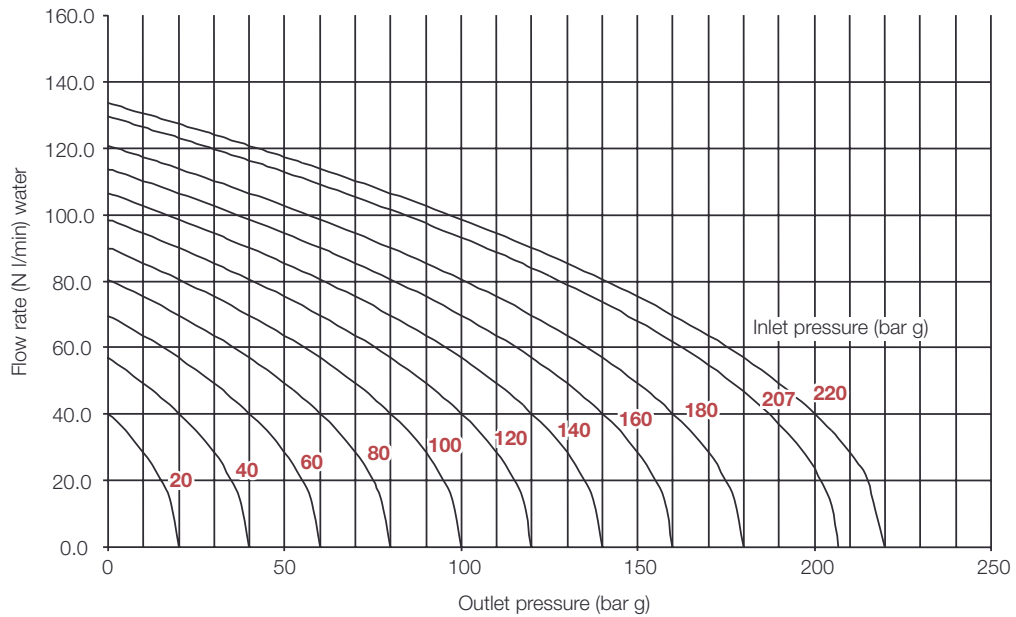
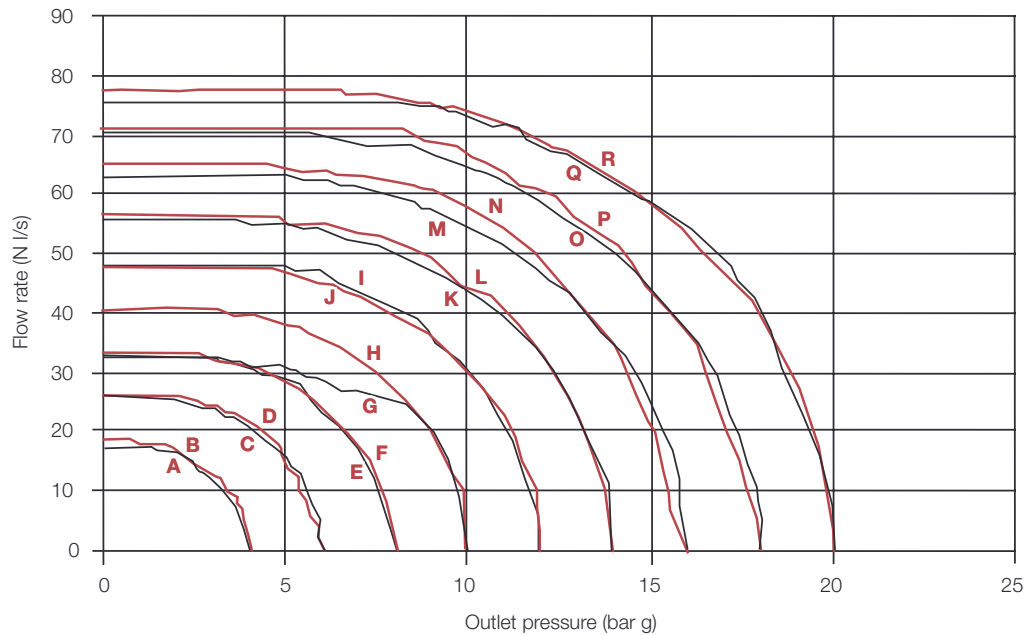

Chart 5.
Flow Test, ICO4 1/4"



- A** Theoretical flow for 4 bar g inlet pressure
- B** Actual flow for 4 bar g inlet pressure
- C** Theoretical flow for 6 bar g inlet pressure
- D** Actual flow for 6 bar g inlet pressure
- E** Theoretical flow for 8 bar g inlet pressure
- F** Actual flow for 8 bar g inlet pressure
- G** Theoretical flow for 10 bar g inlet pressure
- H** Actual flow for 10 bar g inlet pressure
- I** Theoretical flow for 12 bar g inlet pressure
- J** Actual flow for 12 bar g inlet pressure
- K** Theoretical flow for 14 bar g inlet pressure
- L** Actual flow for 14 bar g inlet pressure
- M** Theoretical flow for 16 bar g inlet pressure
- N** Actual flow for 16 bar g inlet pressure
- O** Theoretical flow for 18 bar g inlet pressure
- P** Actual flow for 18 bar g inlet pressure
- Q** Theoretical flow for 20 bar g inlet pressure
- R** Actual flow for 20 bar g inlet pressure

Maxseal Solenoid Valves. Valve Flow Performance.



Chart 6.

Flow Test, ICO4 1/2"

At 10 bar inlet pressure for lift of 0.055"

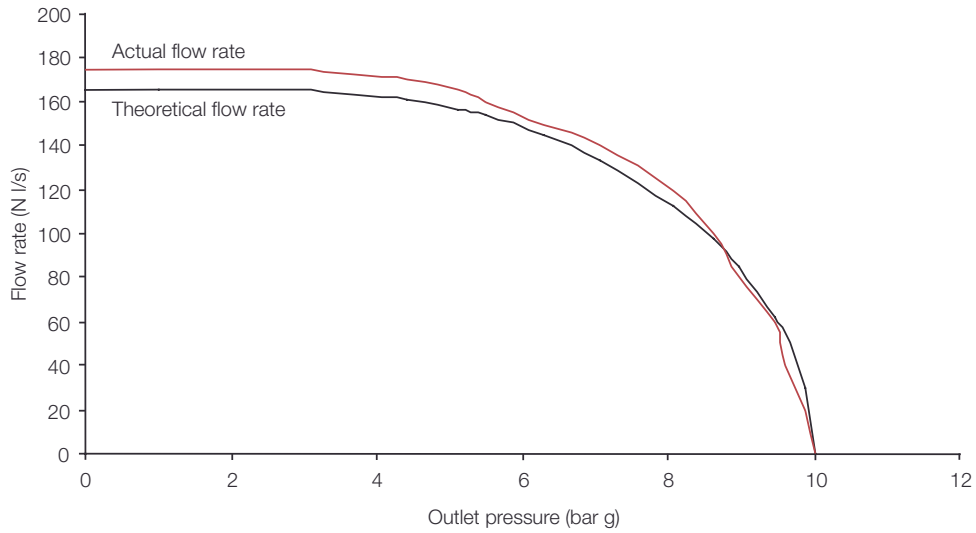
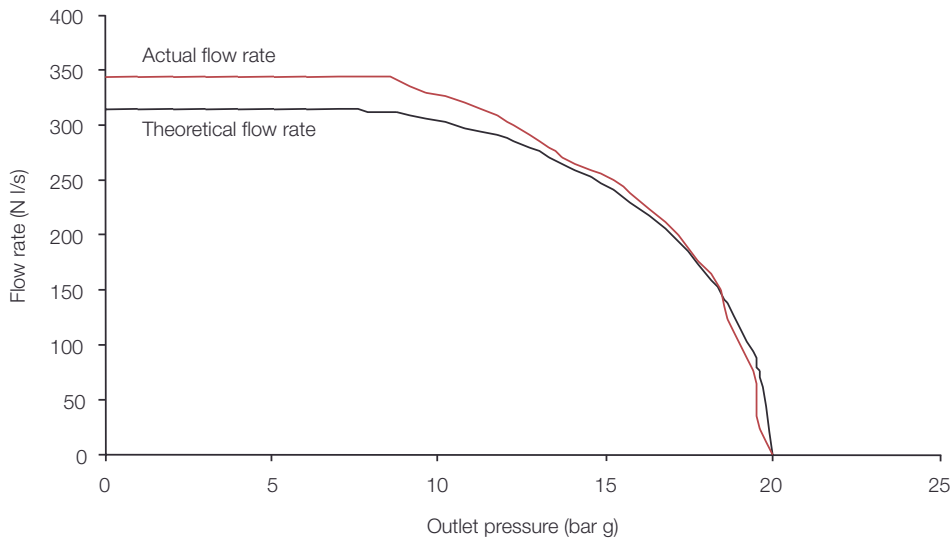

Chart 7.

Flow Test, ICO4 1/2"

At 20 bar inlet pressure for lift of 0.055"



Maxseal Solenoid Valves.

Conversion Chart.



To convert Unit (Symbol)	into Unit (Symbol)	Multiply by
To convert Unit (Symbol)	from Unit (Symbol)	Divide by
atmospheres (Atm)	bar (bar)	1.013250
cubic feet (ft ³)	litres (l)	28.3161
cubic inches (in ³)	centilitres (cl)	1.63866
feet (ft)	metres (m)	0.3048
feet of water (ft H ₂ O)	bar (bar)	0.0298907
foot pounds force (ft lbf)	joules (J)	1.35582
foot pounds force/minute (ft lbf/min)	watts (W)	81.3492
gallons, UK (UK gal)	litres (l)	4.54596
gallons, US (US gal)	litres (l)	3.78531
horsepower (hp)	kilowatts (kW)	0.7457
inches of mercury (in Hg)	millibar (mbar)	33.8639
inches of water (in H ₂ O)	millibar (mbar)	2.49089
inches (in)	centimetres (cm)	2.54
kilogramme force (kgf)	newtons (N)	9.80665
kilogramme force metre (kgf m)	newton metres (Nm)	9.80665
kilopascals (kPa)	bar (bar)	0.01
millimetres of mercury (mm Hg)	millibar (mbar)	1.33322
millimetres of water (mm H ₂ O)	millibar (mbar)	0.09806
newtons/square centimetre (N/cm ²)	bar (bar)	0.1
pounds (lb)	kilogrammes (kg)	0.4536
pounds/cubic foot (lb/ft ³)	kilogrammes/cubic metre (kg/m ³)	16.0185
pounds/cubic inch (lb/in ³)	kilogrammes/cubic centimetre (kg/cm ³)	0.0276799
pounds force (lbf)	newtons (N)	4.44822
pound force feet (lbf ft)	newton metres (Nm)	1.35582
pounds force inches (lbf in)	newton metres (Nm)	0.112985
pounds force/square inch (lbf/in ²)	bar (bar)	0.06894
square feet (ft ²)	square metres (m ²)	0.092903
square inches (in ²)	square centimetres (cm ²)	6.4516



We are here to help!
Remember that complete spares kits are available.

FC^xThompson Valves designs and manufactures exclusive valve products for the most demanding applications. We offer cost-effective integrated product packages, supported by the resources of the FC^x Flow Control division.



Maxseal Solenoid Valves

Resilient, low power consumption, fast acting instrument changeover and solenoid valves.



Ashford Bellows-Sealed and Gland Packed Needle Valves and Manifolds

Compact, lightweight and robust, widely used in nuclear applications.



Maxseal IVP Pressure Regulators

Pressure regulators and relief valves with high performance accuracy for all process fluids, including nuclear applications.



NHI Bellows-Sealed Globe Valves

High-integrity forged valves, specifically designed for nuclear duties.



Service and Refurbishment Centre

Dedicated service engineers for installation and refurbishment.

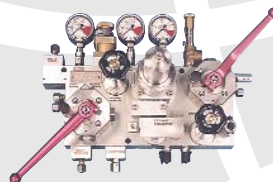

Specialist Packaged Solutions

- HP air management systems.
- Cryogenic valves for aerospace applications.



Classes 1, 2 and 3



BASEEFA/EECS
Licence M3782

A Division of FC^x Manufacturing UK Ltd

FC^xThompson Valves reserves the right to amend product specifications or designs without notice. Information is given in good faith and no liability can be accepted for any error or omission.



BS EN ISO 9001: 1994
Certificate No. FM 315

FC^xThompson Valves
17 Balena Close
Creekmoor, Poole
Dorset BH17 7EF, England
Tel +44 (0)1202 697521
Fax +44 (0)1202 605385
sales@fcx-thompson-valves.com
www.fcx-thompson-valves.com

