

Introduction

Parker U Series Union Bonnet Valves have been engineered for use at pressures up to 6,000 (414 bar) and temperatures as high as 1,200°F (649°C). A non-rotating lower stem helps to extend packing life by removing rotation from the packing area. Stem packing below the threads isolates the thread lubricant from the flow, ensuring adequate lubrication regardless of the media.

Features

- ▶ Union bonnet design ensures high integrity seal under severe service applications
- ▶ Packing below the power threads protects thread lubricants from media and isolates the lubricants from the media
- ▶ Dust seal in the packing nut protects stem threads from external contamination
- ▶ Stem swivel above the packing eliminates entrapment area and increases packing life
- ▶ Choice of Grafoil® or PTFE packing
- ▶ Choice of Regulating or Blunt stem types. Blunt stem type helps combat wire draw which may occur when two phase flow is present (i.e. steam service)
- ▶ 316 stainless steel construction
- ▶ Wide variety of US Customary and SI ports
- ▶ Panel mountable
- ▶ 100% factory tested

Materials of Construction

Item #	Description	Material
*1	Body	ASTM A 182, Type F316
2	Bonnet Nut	ASTM A 479, Type 316
*3	Bonnet	ASTM A 479, Type 316
4	Lower Stem	ASTM A 564, Type 630
5	Upper Stem	ASTM A 564, Type 630
6	Stem Guide	ASTM A 581, Type 416
7	Ball	440-C Stainless Steel
*8	Bonnet Seal**	Nickel-Chromium-Iron Alloy
9	Packing Nut	ASTM A 479, Type 316
*10	Packing***	Grafoil®
*11	Packing Washer	316 Stainless Steel
12	Handle****	Aluminum
13	Handle Screw	316 Stainless Steel
14	Dust Seal*****	Nylon 6/6
15	Locking Nut	Stainless Steel

* Wetted parts

* Lower Stem material is ASTM A 276 Type 316 with HT option

** Not required on U6 and U12 Series which have metal-to-metal seals

*** Optional PTFE Packing is available

**** Handle material is stainless steel with HT option

***** Dust Seal not available with HT option

Lubrication: Molybdenum disulfide with soft metallic fillers

Specifications

Pressure Rating:

6000 psig (414 bar) CWP

Temperature Rating:

PTFE packing:

-65°F to 450°F (-54°C to 232°C)

Grafoil® packing:

-65°F to 700°F (-54°C to 371°C)

Grafoil® packing with HT option:

-65°F to 1200°F (-54°C to 649°C)

Orifice: .177" to .437" (4.5mm to 11.1mm)

Cv: .53 to 3.55

Pressure Rating and Tubing Selection:

For working pressures of A-LOK® and CPI™ tube connections, please see the Instrument Tubing Selection Guide (Bulletin 4200-TS), found in the Technical Section of the Parker Instrumentation Products Master Binder, or the Parker Instrument Tube Fitting Installation Manual (Bulletin 4200-B4).

For working pressures of valves with external or internal pipe threads, please see Catalog 4260, Instrumentation Pipe Fittings.

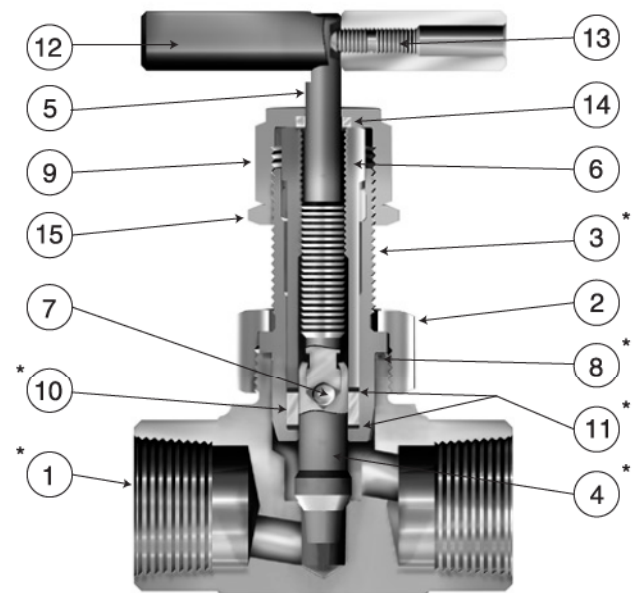

Model Shown: 16F-U16LR-G-SS

Grafoil® is a registered trademark GrafTech International Holdings, Inc.

Pressure vs. Temperature

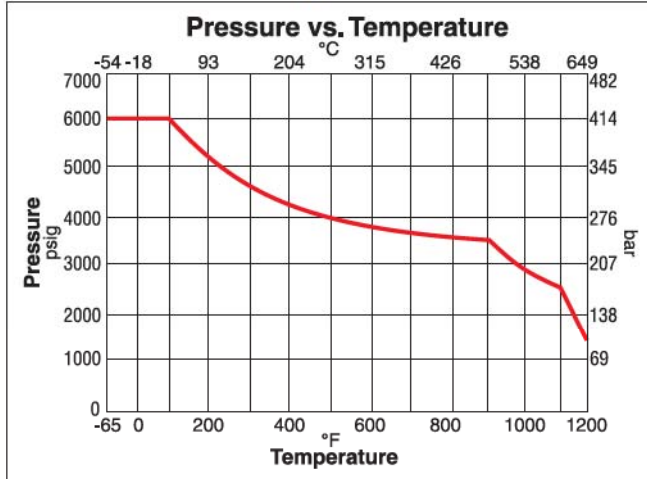

Flow Characteristics

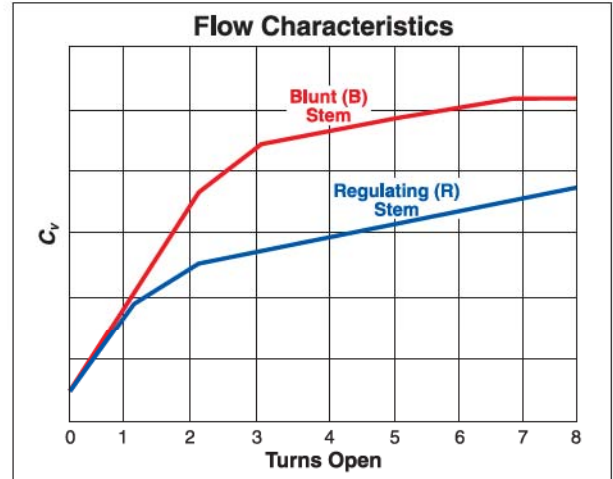

U6 Series Dimensions / Flow Data

Model Shown:
4Z-U6LB-T-SS

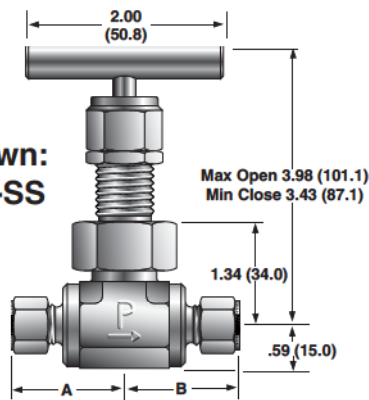

Panel Hole Diameter:
0.65 (16.5)
Max Panel Thickness:
0.42 (10.7)

Model Shown:
4F-U6AR-T-SS

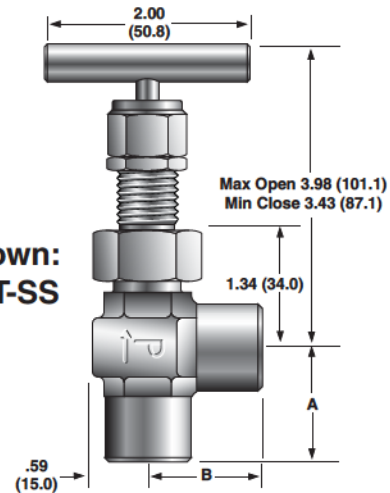

() Denotes dimensions
in millimeters

Basic Part Number		End Connections		Stem Type	Flow Data				Dimensions					
Inline	Angle	Inlet (Port 1)	Outlet (Port 2)		Orifice		Inline		Angle		A†		B†	
					Inch	mm	Cv	X _T *	Cv	X _T *	Inch	mm	Inch	mm
2F-U6LR	2F-U6AR	1/8" Female NPT		Regulating	0.188	4.8	0.58	0.83	0.77	0.70	1.00	25.4	1.00	25.4
2F-U6LB	2F-U6AB			Blunt			0.69	0.50	0.91	0.42				
4A-U6LR	4A-U6AR	1/4" Compression A-LOK®		Regulating	0.177	4.5	0.53	0.80	0.70	0.67	1.38	35.1	1.38	35.1
4A-U6LB	4A-U6AB			Blunt			0.65	0.48	0.86	0.40				
4F-U6LR	4F-U6AR	1/4" Female NPT		Regulating	0.228	5.8	0.78	0.95	1.04	0.80	1.03	26.2	1.03	26.2
4F-U6LB	4F-U6AB			Blunt			0.82	0.59	1.09	0.50				
4M-U6LR	4M-U6AR	1/4" Male NPT		Regulating	0.177	4.5	0.53	0.80	0.70	0.67	1.09	27.7	1.09	27.7
4M-U6LB	4M-U6AB			Blunt			0.65	0.48	0.86	0.40				
4W-U6LR	4W-U6AR	1/4" Socket Weld		Regulating	0.177	4.5	0.53	0.80	0.70	0.67	.91	23.1	.91	23.1
4W-U6LB	4W-U6AB			Blunt			0.65	0.48	0.86	0.40				
4Z-U6LR	4Z-U6AR	1/4" Compression CPI™		Regulating	0.177	4.5	0.53	0.80	0.70	0.67	1.38	35.1	1.38	35.1
4Z-U6LB	4Z-U6AB			Blunt			0.65	0.48	0.86	0.40				
M6A-U6LR	M6A-U6AR	6mm Compression A-LOK®		Regulating	0.177	4.5	0.53	0.80	0.70	0.67	1.38	35.1	1.38	35.1
M6A-U6LB	M6A-U6AB			Blunt			0.65	0.48	0.86	0.40				
M6Z-U6LR	M6Z-U6AR	6mm Compression CPI™		Regulating	0.177	4.5	0.53	0.80	0.70	0.67	1.38	35.1	1.38	35.1
M6Z-U6LB	M6Z-U6AB			Blunt			0.65	0.48	0.86	0.40				
M8A-U6LR	M8A-U6AR	8mm Compression A-LOK®		Regulating	0.177	4.5	0.53	0.80	0.70	0.67	1.38	35.1	1.38	35.1
M8A-U6LB	M8A-U6AB			Blunt			0.65	0.48	0.86	0.40				
M8Z-U6LR	M8Z-U6AR	8mm Compression CPI™		Regulating	0.177	4.5	0.53	0.80	0.70	0.67	1.38	35.1	1.38	35.1
M8Z-U6LB	M8Z-U6AB			Blunt			0.65	0.48	0.86	0.40				

* Tested in accordance with ISA S75.02. Gas flow will be choked when $P_1 - P_2 / P_1 = X_T$.
 † For CPI™ and A-LOK®, dimensions are measured with nuts in the finger tight position.

Dimensions in inches/millimeters are for reference only, subject to change.

U12 Series Dimensions / Flow Data

Model Shown:
6F-U12LB-G-SS-HT

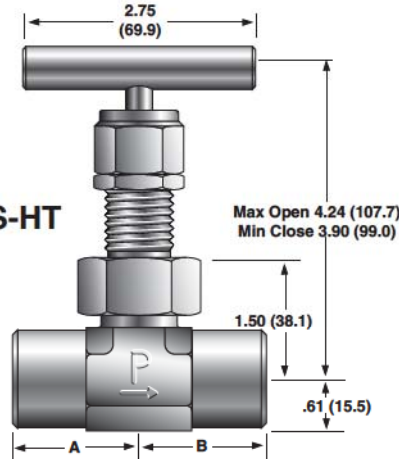

Panel Hole Diameter:
0.83 (21.1)
Max Panel Thickness:
0.61 (15.5)

Model Shown:
8A-U12AB-T-SS

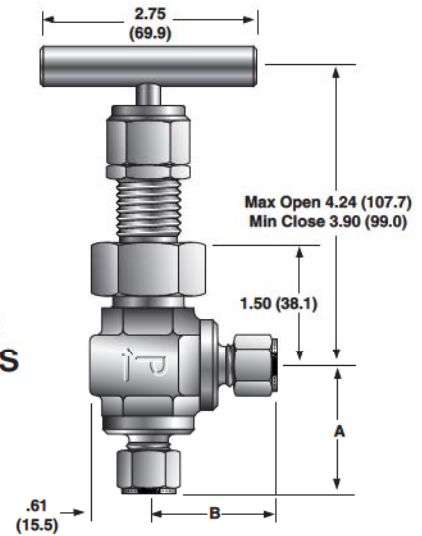

() Denotes dimensions in millimeters

Basic Part Number		End Connections		Stem Type	Flow Data				Dimensions					
Inline	Angle	Inlet (Port 1)	Outlet (Port 2)		Orifice	Inline		Angle		A†		B†		
					Inch	mm	C_V	X_T^*	C_V	X_T^*	Inch	mm	Inch	mm
4A-U12LR	4A-U12AR	1/4" Compression A-LOK®	Regulating	Blunt	0.125	3.2	0.44	0.57	0.60	0.49	1.39	35.3	1.39	35.3
4A-U12LB	4A-U12AB						0.51	0.40	0.68	0.33				
4F-U12LR	4F-U12AR	1/4" Female NPT	Regulating	Blunt	0.250	6.4	0.94	0.65	1.25	0.55	1.13	28.7	1.13	28.7
4F-U12LB	4F-U12AB						1.03	0.60	1.37	0.51				
4Z-U12LR	4Z-U12AR	1/4" Compression CPI™	Regulating	Blunt	0.125	3.2	0.44	0.57	0.60	0.49	1.39	35.3	1.39	35.3
4Z-U12LB	4Z-U12AB						0.51	0.40	0.68	0.33				
6A-U12LR	6A-U12AR	3/8" Compression A-LOK®	Regulating	Blunt	0.187	4.7	0.69	0.61	0.92	0.52	1.60	40.6	1.60	40.6
6A-U12LB	6A-U12AB						0.77	0.50	1.02	0.42				
6F-U12LR	6F-U12AR	3/8" Female NPT	Regulating	Blunt	0.312	7.9	1.19	0.78	1.58	0.66	1.30	33.0	1.30	33.0
6F-U12LB	6F-U12AB						1.31	0.80	1.74	0.68				
6W-U12LR	6W-U12AR	3/8" Tube Socket Weld	Regulating	Blunt	0.228	5.8	0.85	0.64	1.13	0.54	1.13	28.7	1.13	28.7
6W-U12LB	6W-U12AB						0.94	0.57	1.25	0.48				
6Z-U12LR	6Z-U12AR	3/8" Compression CPI™	Regulating	Blunt	0.187	4.7	0.69	0.61	0.92	0.52	1.60	40.6	1.60	40.6
6Z-U12LB	6Z-U12AB						0.77	0.50	1.02	0.42				
8A-U12LR	8A-U12AR	1/2" Compression A-LOK®	Regulating	Blunt	0.250	6.4	0.94	0.65	1.25	0.55	1.49	37.8	1.49	37.8
8A-U12LB	8A-U12AB						1.03	0.60	1.37	0.51				
8F-U12LR	8F-U12AR	1/2" Female NPT	Regulating	Blunt	0.312	7.9	1.19	0.78	1.58	0.66	1.50	38.1	1.50	38.1
8F-U12LB	8F-U12AB						1.31	0.80	1.74	0.68				
8W-U12LR	8W-U12AR	1/2" Tube Socket Weld	Regulating	Blunt	0.312	7.9	1.19	0.78	1.58	0.66	1.25	31.8	1.25	31.8
8W-U12LB	8W-U12AB						1.31	0.80	1.74	0.68				
8Z-U12LR	8Z-U12AR	1/2" Compression CPI™	Regulating	Blunt	0.250	6.4	0.94	0.65	1.25	0.55	1.49	37.8	1.49	37.8
8Z-U12LB	8Z-U12AB						1.03	0.60	1.37	0.51				
M10A-U12LR	M10A-U12AR	10mm Compression A-LOK®	Regulating	Blunt	0.250	6.4	0.94	0.65	1.25	0.55	1.53	38.9	1.53	38.9
M10A-U12LB	M10A-U12AB						1.03	0.60	1.37	0.51				
M10Z-U12LR	M10Z-U12AR	10mm Compression CPI™	Regulating	Blunt	0.250	6.4	0.94	0.65	1.25	0.55	1.53	38.9	1.53	38.9
M10Z-U12LB	M10Z-U12AB						1.03	0.60	1.37	0.51				
M12A-U12LR	M12A-U12AR	12mm Compression A-LOK®	Regulating	Blunt	0.312	7.9	1.19	0.78	1.58	0.66	1.70	43.2	1.70	43.2
M12A-U12LB	M12A-U12AB						1.31	0.80	1.74	0.68				
M12Z-U12LR	M12Z-U12AR	12mm Compression CPI™	Regulating	Blunt	0.312	7.9	1.19	0.78	1.58	0.66	1.70	43.2	1.70	43.2
M12Z-U12LB	M12Z-U12AB						1.31	0.80	1.74	0.68				
M14A-U12LR	M14A-U12AR	14mm Compression A-LOK®	Regulating	Blunt	0.312	7.9	1.19	0.78	1.58	0.66	1.70	43.2	1.70	43.2
M14A-U12LB	M14A-U12AB						1.31	0.80	1.74	0.68				
M14Z-U12LR	M14Z-U12AR	14mm Compression CPI™	Regulating	Blunt	0.312	7.9	1.19	0.78	1.58	0.66	1.70	43.2	1.70	43.2
M14Z-U12LB	M14Z-U12AB						1.31	0.80	1.74	0.68				

* Tested in accordance with ISA S75.02. Gas flow will be choked when $P_1 - P_2 / P_1 = X_T$.
† For CPI™ and A-LOK®, dimensions are measured with nuts in the finger tight position.

Dimensions in inches/millimeters are for reference only, subject to change.

U16 Series Dimensions / Flow Data

Model Shown:
16M-U16LR-G-SS

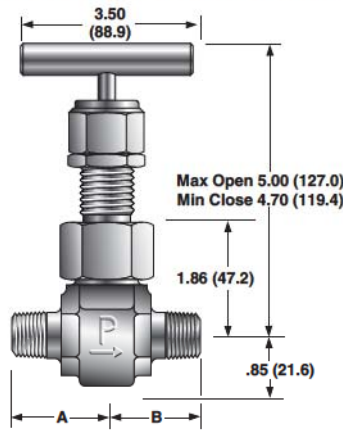

Panel Hole Diameter:
1.02 (25.9)
Max Panel Thickness:
0.62 (15.7)

Model Shown:
16M16F-U16AB-T-SS

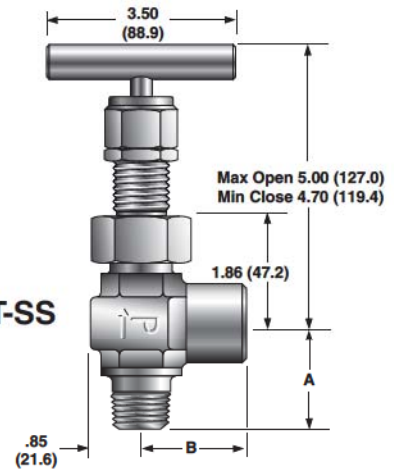

() Denotes dimensions in millimeters

Basic Part Number		End Connections		Stem Type	Flow Data				Dimensions					
Inline	Angle	Inlet (Port 1)	Outlet (Port 2)		Orifice		Inline		Angle		A†		B†	
					Inch	mm	C _v	X _T *	C _v	X _T *	Inch	mm	Inch	mm
8A-U16LR	8A-U16AR	1/2" Compression A-LOK®		Regulating	0.394	10.0	1.59	0.73	2.11	0.62	1.97	50.0	1.97	50.0
8A-U16LB	8A-U16AB			Blunt										
8F-U16LR	8F-U16AR	1/2" Female NPT		Regulating	0.437	11.1	1.82	0.72	2.42	0.61	1.56	39.6	1.56	39.6
8F-U16LB	8F-U16AB			Blunt										
8M-U16LR	8M-U16AR	1/2" Male NPT		Regulating	0.437	11.1	1.82	0.72	2.42	0.61	1.92	48.8	1.92	48.8
8M-U16LB	8M-U16AB			Blunt										
8PSW-U16LR	8PSW-U16AR	1/2" Pipe Socket Weld		Regulating	0.437	11.1	1.82	0.72	2.42	0.61	1.56	39.6	1.56	39.6
8PSW-U16LB	8PSW-U16AB			Blunt										
8W-U16LR	8W-U16AR	1/2" Tube Socket Weld		Regulating	0.394	10.0	1.59	0.73	2.11	0.62	1.69	42.9	1.69	42.9
8W-U16LB	8W-U16AB			Blunt										
8Z-U16LR	8Z-U16AR	1/2" Compression CPI™		Regulating	0.394	10.0	1.59	0.73	2.11	0.62	1.97	50.0	1.97	50.0
8Z-U16LB	8Z-U16AB			Blunt										
12A-U16LR	12A-U16AR	3/4" Compression A-LOK®		Regulating	0.437	11.1	1.82	0.72	2.42	0.61	1.97	50.0	1.97	50.0
12A-U16LB	12A-U16AB			Blunt										
12F-U16LR	12F-U16AR	3/4" Female NPT		Regulating	0.437	11.1	1.82	0.72	2.42	0.61	1.63	41.4	1.63	41.4
12F-U16LB	12F-U16AB			Blunt										
12M-U16LR	12M-U16AR	3/4" Male NPT		Regulating	0.437	11.1	1.82	0.72	2.42	0.61	1.63	41.4	1.63	41.4
12M-U16LB	12M-U16AB			Blunt										
12PSW-U16LR	12PSW-U16AR	3/4" Pipe Socket Weld		Regulating	0.437	11.1	1.82	0.72	2.42	0.61	1.56	39.6	1.56	39.6
12PSW-U16LB	12PSW-U16AB			Blunt										
12W-U16LR	12W-U16AR	3/4" Tube Socket Weld		Regulating	0.437	11.1	1.82	0.72	2.42	0.61	1.56	39.6	1.56	39.6
12W-U16LB	12W-U16AB			Blunt										
12Z-U16LR	12Z-U16AR	3/4" Compression CPI™		Regulating	0.437	11.1	1.82	0.72	2.42	0.61	1.97	50.0	1.97	50.0
12Z-U16LB	12Z-U16AB			Blunt										
16A-U16LR	16A-U16AR	1" Compression A-LOK®		Regulating	0.437	11.1	1.82	0.72	2.42	0.61	1.97	50.0	1.97	50.0
16A-U16LB	16A-U16AB			Blunt										
16F-U16LR	16F-U16AR	1" Female NPT		Regulating	0.437	11.1	1.82	0.72	2.42	0.61	1.81	46.0	1.81	46.0
16F-U16LB	16F-U16AB			Blunt										
16M-U16LR	16M-U16AR	1" Male NPT		Regulating	0.437	11.1	1.82	0.72	2.42	0.61	1.81	46.0	1.81	46.0
16M-U16LB	16M-U16AB			Blunt										
16Z-U16LR	16Z-U16AR	1" Compression CPI™		Regulating	0.437	11.1	1.82	0.72	2.42	0.61	1.97	50.0	1.97	50.0
16Z-U16LB	16Z-U16AB			Blunt										
M12A-U16LR	M12A-U16AR	12mm Compression A-LOK®		Regulating	0.394	10.0	1.59	0.73	2.11	0.62	1.97	50.0	1.97	50.0
M12A-U16LB	M12A-U16AB			Blunt										
M12Z-U16LR	M12Z-U16AR	12mm Compression CPI™		Regulating	0.394	10.0	1.59	0.73	2.11	0.62	1.97	50.0	1.97	50.0
M12Z-U16LB	M12Z-U16AB			Blunt										
M20A-U16LR	M20A-U16AR	20mm Compression A-LOK®		Regulating	0.437	11.1	1.82	0.72	2.42	0.61	1.97	50.0	1.97	50.0
M20A-U16LB	M20A-U16AB			Blunt										
M20Z-U16LR	M20Z-U16AR	20mm Compression CPI™		Regulating	0.437	11.1	1.82	0.72	2.42	0.61	1.97	50.0	1.97	50.0
M20Z-U16LB	M20Z-U16AB			Blunt										
M25A-U16LR	M25A-U16AR	25mm Compression A-LOK®		Regulating	0.437	11.1	1.82	0.72	2.42	0.61	1.97	50.0	1.97	50.0
M25A-U16LB	M25A-U16AB			Blunt										
M25Z-U16LR	M25Z-U16AR	25mm Compression CPI™		Regulating	0.437	11.1	1.82	0.72	2.42	0.61	1.97	50.0	1.97	50.0
M25Z-U16LB	M25Z-U16AB			Blunt										

* Tested in accordance with ISA S75.02. Gas flow will be choked when $P_1 - P_2 / P_1 = X_T$.

† For CPI™ and A-LOK®, dimensions are measured with nuts in the finger tight position.

Dimensions in inches/millimeters are for reference only, subject to change.

How to Order

Dimensions in inches/millimeters are for reference only, subject to change.

The correct part number is easily derived from the following example and ordering chart. The six product characteristics required are coded as shown in the chart.

The example below describes an angle pattern U6 Series needle valve equipped with 1/4" CPI™ compression inlet and outlet ports, a regulating stem type, Grafoil® packing, stainless steel construction.

Example 1: 4Z-U6AR-G-SS

4Z		-		U6A		R		-		G		-		SS		
Inlet Port*		Outlet Port*		Valve Series		Stem Type		Packing		Body Material						
Inlet Port*		Outlet Port*		Valve Series		Stem Type		Packing		Body Material						
2F	4F	4W	M6A	M8	U6A	B	Blunt	T	PTFE	SS	Stainless Steel					
4A	4M	4Z	M6Z	M8Z	U6L	R	Regulating	G	Grafoil®							
4A	6W	8W	12A	M12A	U12A											
4F	6Z	8Z	12Z	M12Z	U12L											
4Z	8A	10A	M10A	M14A												
6A	8F	10Z	M10Z	M14Z												
6F																
8A	8W	12PSW	16M	M20Z	U16A											
8F	8Z	12W	16Z	M25A	U16L											
8M	12F	12Z	M12Z	M25Z												
8PSW	12M	16F	M20A													

*If the inlet and outlet ports are the same, eliminate the outlet port designator.

How to Order Options

High Temperature – Add the suffix **-HT** to the end of the part number to receive valves with a 316 stainless steel lower stem and stainless steel handle. **Example:** 4M-U6LB-G-SS-HT

Oxygen Cleaning – Add the suffix **-C3** to the end of the part number to receive valves cleaned and assembled for oxygen service in accordance with Parker Specification ES8003. **Example:** 8A-U12LR-T-SS-C3

Stainless Steel Bar Handle – To obtain valves with stainless steel bar handle, add the suffix **-ST** to the end of the part number. **Example:** 12Z-U16AB-T-SS-ST

ASME B31.1 Compliant Valves – Add the suffix **-QC311**. **Example:** 8F-U12LR-G-SS-QC311

How to Order Maintenance Kits

Stainless Steel T-Bar Handles with Handle Screw – **Examples:** U6: V4-BAR-HANDLE-SS; U12:U12-BAR-HANDLE-SS; U16: U16-BAR-HANDLE-SS

Aluminum T-Bar Handles with Handle Screw – **Examples:** U6: V4-BAR-HANDLE-AL; U12:U12-BAR-HANDLE-AL; U16: U16-BAR-HANDLE-AL

Panel Mounting Nuts – **Examples:** U6: U6-LOCKNUT; U12: U12-LOCKNUT; U16: U16-LOCKNUT

PTFE Packing Kits – Consists of One PTFE Packing; One Dust Seal; Maintenance Instructions. Kit-Valve Series-T. **Example:** KIT-U12-T

Grafoil® Packing Kits – Consists of One Grafoil® Packing; One Dust Seal; Maintenance Instructions. Kit-Valve Series-G. **Example:** KIT-U16-G

Grafoil® is a registered trademark GrafTech International Holdings, Inc.