

10A3220/
10A3250

Armored Purgemeter

Instruction Bulletin

D184B003U33 Rev. 01 / 01.2001



ABB

You have purchased a high quality, modern Flowmeter from ABB Automation Products. We thank you for your purchase and the confidence you have shown in us.

This Instruction Bulletin contains the instructions relating to the assembly and installation of the instrument and the specifications for this instrument design. ABB Automation Products reserves the right to make hardware and software refinements which enhance the operation of the instrument without prior notice.

Should any questions arise that are not specifically answered by these instructions please contact us at our main plant in Göttingen, Germany Tel. 49-551/905-0 or one of our Technical Sales Bureaus

Operating Safety Information

Please read this Instruction Bulletin and the safety notes before attempting installation of the flowmeter system.

Only qualified personnel should have access to the instrument. The personnel should be familiar with the warnings and operating requirements described in this Instruction Bulletin.

Ground the flowmeter system when electronic elements are installed in the indicator housing (see Instrument Tag and Interconnection Diagram).

When housing cover and the power is turned on there is no personnel contact protection!

Observe the warning notes indicated in this document by the symbol:



Hazardous Material Information Repairs

In view of the Disposal Law of 27.08.86 (AbfG. 11 Special Wastes) the owner of special wastes is responsible for its care and the employer also has, according to the Hazardous Material Law of 01.10.86 (GefStoffV, §17 General Protection Responsibility), a responsibility to protect his employees, we must make note that:

- a) All flowmeter primaries and/or flowmeter converters which are returned to ABB Automation Products for repair are to be free of any hazardous materials (acids, bases, solutions, etc.)
 - b) The flowmeter primaries must be flushed so that the hazardous materials are neutralized. There are cavities in the flowmeter housing. Therefore after metering hazardous materials the cavities are to be neutralized (see Hazardous Material Law -GefStoffV). To accomplish this it is necessary to remove the float and float stop from the flowmeter housing.
 - c) For service and repairs **written confirmation** is required that the measures listed in a) and b) have been carried out.
 - d) Any costs incurred to remove the hazardous materials during a repair will be billed to the owner of the equipment.
-

Contents	Page
1. Principle of Operation	1
2. Installation	1
2.1 Installation Requirements	1
2.2 Pressure Drop	2
2.3 Minimum Required Pressure Drop for Gas Metering	2
2.4 Fluids Containing Solids	2
3. Temperature Specifications	2
3.1 Specifications for Accessories	3
4. Maintenance	4
4.1 Cleaning	4
4.2 Removal of the Float and Metering Tube	4
4.2.1 Vertical Connections	4
4.2.2 Horizontal Connections	4
4.2.3 Horizontal and Vertical Connections	4
4.3 Replacement Part Orders	4
5. Recommended Switch Amplifier for Alarm Signal Transmitter	4
6. Replaceable Parts List	5
6.1 10A3220 Horizontal Design 1 - 100 l/h Water	5
6.2 10A3225 Vertical Design, 1 - 100 l/h Water	7
6.3 Indicator with/without Alarm	9
6.4 Indicator with Angular Rotation Transmitter	11

1. Principle of Operation

Armored Metal Tube Flowmeter Series 10A3220

The Series 10A3220 flowmeters are metal tube flowmeters in which a float moves in a conical, vertical meter tube. These flowmeters provide a local indication of the instantaneous flowrate value and incorporate a built-in alarm switch for monitoring the flowrate value. They are also available with a differential pressure regulator.

Flowmeters with an all metal construction can be used in applications where sudden pressure shocks may occur and/or where the metering of flammable or aggressive fluids precludes the use of glass tube flowmeters.



Fig. 1 10A3220

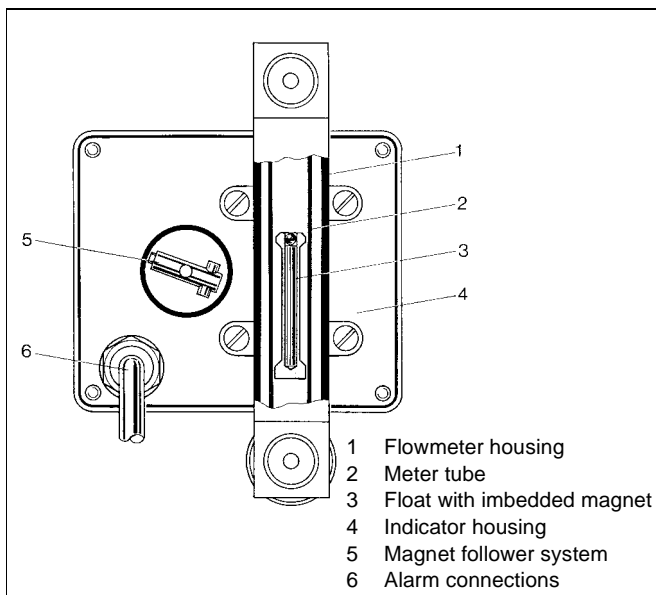

Fig. 2 Cross Section Conical Meter tube Principle

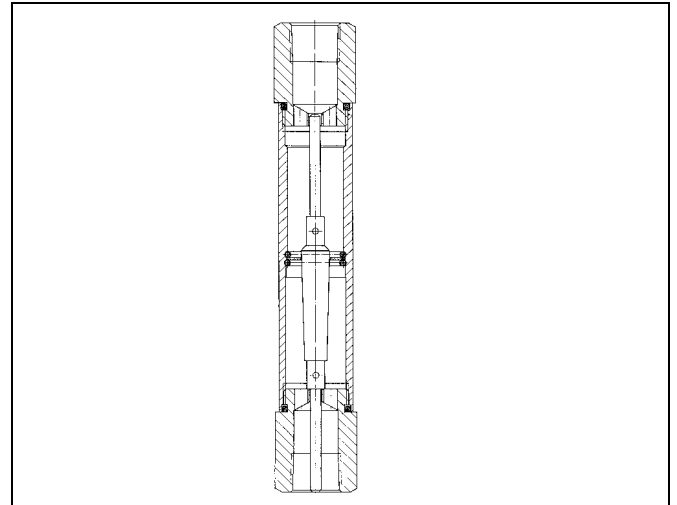

Fig. 3 Cross Section Float and Orifice Principle

2. Installation

2.1 Installation Requirements

- Remove the **shipping protection**.
- The installation **orientation** must be **vertical**.
- The flowmeter should be isolated from pipeline vibrations. Pipeline mounting is sufficient in normal situations.
- Unobstructed **in- and outlet sections** are not required. Valves or elbows may be connected directly to the meter.
- Observe the limits listed in the Specification Sheet.
- Take care to avoid stray magnetic fields which could affect the metering results.
- When the flowmeter is to be installed in a pipeline in which interruption of service is undesirable or impossible, a bypass line should be installed as shown in Fig. 4.
- See also VDI/VDE Guideline 3513 Sheet 3 "Selection and Installation Recommendations for Variable Area Flowmeters".

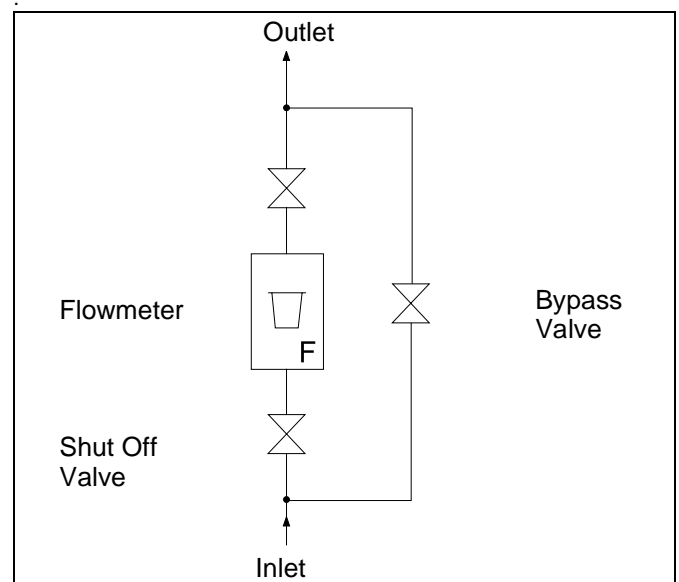

Fig. 4 Installation Example

Armored Purgemeter

2.2 Pressure Drop

The pressure which exists at the flowmeter must be sufficient to satisfy the pressure drop through the flowmeter primary. This pressure drop is made up of the constant pressure drop at the float and the pressure drop through the fittings and the flowmeter. The later increases as the square of the flow velocity. The pressure drop values are listed in the Specification Sheet.

2.3 Minimum Required Pressure Drop for Gas Metering

Even with pulsation free flows spontaneous pulsations of the float are possible (float bounce). These pulsations generally occur when the critical volume before and after the float to the nearest throttle point up- or downstream from the flowmeter is exceeded and when both the pressure and flowrate are low. If the operating pressure is below the minimum value listed in the Specification Sheet, it is possible to provide a design with gas damping to eliminate the pulsations.

To eliminate the self-induced compression pulsations the following measures can be employed:

- Select a flowmeter with the lowest pressure drop specifications.
- Utilize short pipe sections between the flowmeter and the up- or downstream throttling locations.
- The inside diameter of the pipeline should not be larger than the flowmeter connection size.
- Reduce the flowrate range from the usual 10% - 100% to 25% - 100%.
- Set the flowrate by approaching the required value from a higher flowrate.
- Increase the operating pressure while taking into account the increase in the flowrate indication due to the increase in the gas density at the new operating conditions.

2.4 Fluids Containing Solids

For fluids which contain magnetic particles, such as iron filings, etc., the danger exists that these magnetic particles may become attached to the float. The accuracy will be affected in an adverse manner.

In such applications we recommend the use of a magnetic separator. During installation of the flowmeter it is positioned between the flanges of the pipeline and the meter (see Fig. 4).

In general solid particles in the fluid cause increased mechanical friction and thereby increased wear on the float metering edge. In such installations an appropriate filter should be provided.

3. Temperature Specifications

Temperature Limits:

O-Rings	O-Ring Viton A	150°C
	O-Ring Buna N	120°C
Meter tube holder	PVDF	100°C
	PTFE	260°C
Alarm transmitter	Non Ex-Design	100°C
	Ex-Design	80°C T4 45°C T6
Rotation converter.	Ex-Design	50°C T4 40°C T6

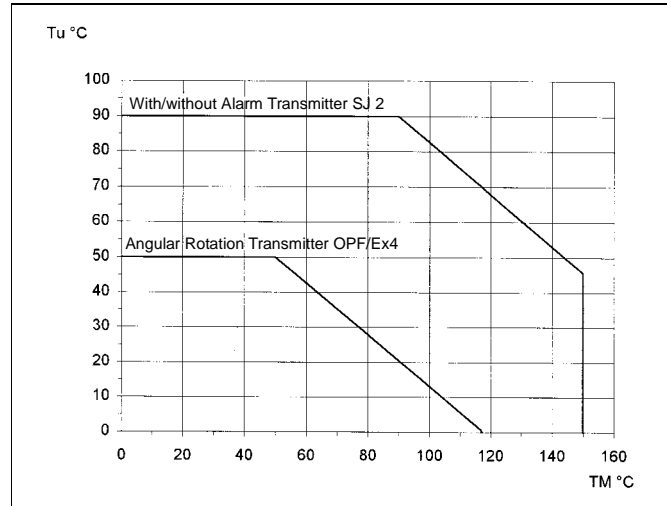

Fig. 5 10A3220/25 Non Ex-Design (w/wo Alarm Transmitter and Angular Rotation Transmitter)

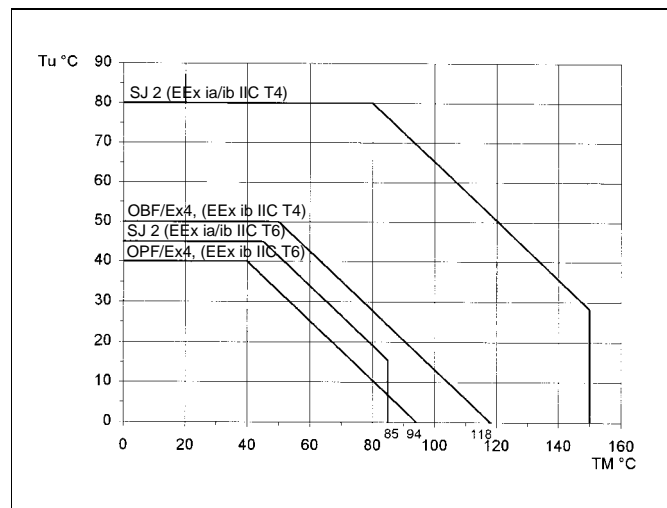

Fig. 6 10A3220/25 with Alarm Transmitter SJ 2, (EEx ia/ib IIC T4/T6, PTB No.: Ex-83/2022) and Angular Rotation Transmitter OPF/Ex4, (EEx ib IIC T4/T6, 90C.980 14X)

Tu = Ambient Temperature

TM = Fluid Temperature

3.1 Specifications for Accessories

Alarm Contacts, Models D10A3220/25 ¹⁾

Alarm contacts can be installed in the flowmeter housing that react to min.- and/or max. flowrate limits. They can be utilized to control pumps, magnetic valves, etc. (Fig. 7).

The Alarm Signal Transmitter consists of a slot initiator and a switch amplifier. The switch amplifier is installed separately and not in the indicator housing. A control vane actuates the alarm circuit when it enters the slot initiator. The slot initiator position can be set using a screwdriver.

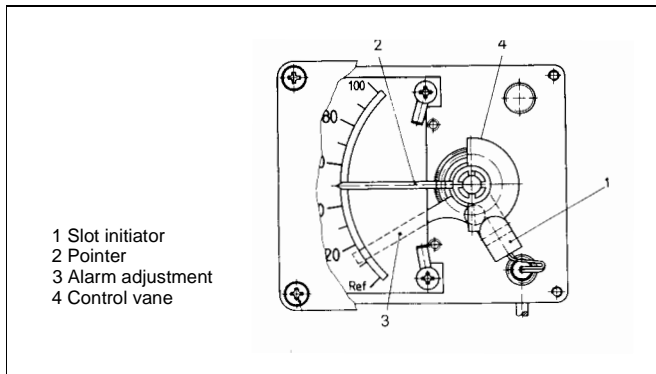

Fig. 7 Armored Purgemeter 10A3220 Indicator with Single Alarm

Alarm Signal Transmitter	Slot Initiator Type SJ2-N (Pepperl & Fuchs)
Ambient Temperature	-20 °C to +45 °C
Certificate of Conformity	PTB Ex 83/2022X EEx ia IIc T6; EEx ib IIc T6
Alarm Point Setting	
Single alarm	Min. 0 to 60% Max. 40 to 100%
Double alarm	Min. range setting approx. 5%
Setting Accuracy	±2% or rate

Electr. Converter ¹⁾

Type: OPF Ex 4-2R/L.P. (Mfg'r. Tempres A/S)

Model 10A3250/55-Ex

The Model 10A3250/55 are flowmeters with an integral Angular Rotation Transmitter. The transmitter is mounted on the indicator shaft and converts the pointer indication into a proportional 4-20 mA current output signal.

Output Signal 4-20 mA-/2-Wire

U_{max}	30 V
I_{max}	30 mA
$C_i \leq 50$ nF; $L_i \leq 360$ μH	

Ambient Temperature

-20°C to +40°C

Certificate of Conformity

DEMCO-No. 90C.98014X, EEX ib IIC T6

Zero Setting

Position the pointer of the magnet follower system to the lowest scale graduation (e.g. percent scale=10%, direct reading scale 30 - 300l/h = 30l/h).. The output signal for this pointer setting can be calculated as follows:

$$\text{Percent Scale: } I[\text{mA}] = \left(16\text{mA} \cdot \frac{\% \text{min}}{100} \right) + 4\text{mA}$$

$$\text{DR. Scale: } I[\text{mA}] = \left(16\text{mA} \cdot \frac{Q_v \text{min}}{Q_v \text{max}} \right) + 4\text{mA}$$

The output signal can be adjusted when required by turning the potentiometer "ZERO".

Span Setting

Position the pointer at the 100% scale graduation or at the highest graduation on a direct reading scale. The potentiometer "SPAN" should be adjusted so that the output signal value is exactly 20mA. It is recommended that the zero setting be rechecked.

Warning!

- For non-linear scales, e.g. due to viscosity effects, a linearization unit is required. In many situations an adjustment made at a single point is satisfactory. If required, please contact the factory.

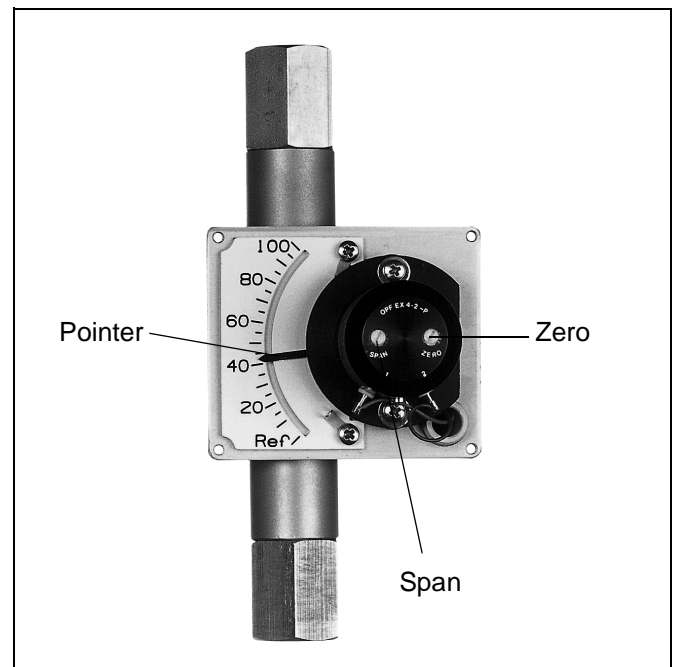

Fig. 8

1) Available as an option

Armored Purgemeter

Differential Pressure Regulator Model 53RT2110¹⁾ Model 10A3220

The differential pressure regulator is used in conjunction with the Armored Purgemeter. It maintains a constant flowrate through the flowmeter whose value is set using the needle valve.

Max. Allow. Diff. Pressure 7 bar

Connections R 1/4"

Materials

Housing Stn. stl. 316Ti [No.1.4571]

Diaphragm Viton A (max. 150°C)*

O-Rings Viton A*

Springs Stn. stl. 316 [No.1.4401]

Valve seat and shaft Stn. stl. 316 [No.1.4401]

Connecting pipe Stn. stl. 304 [No.1.4301]

Pipe coupling Stn. stl. 304 [No.1.4301]

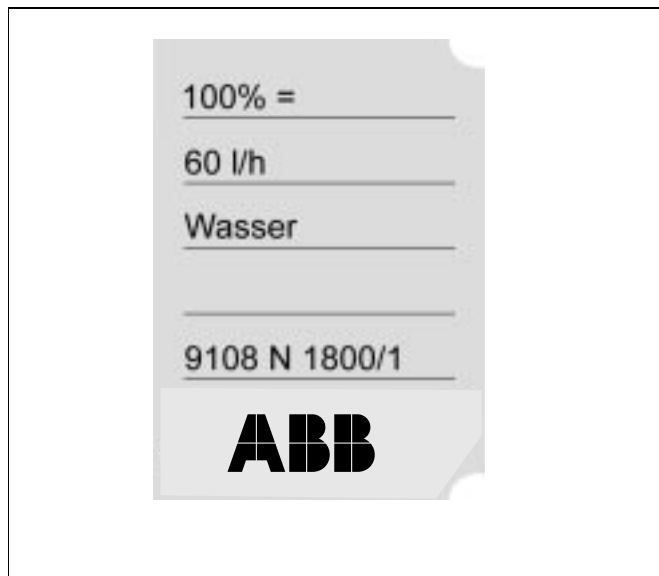

Fig. 9 Typical Instrument Tag

4. Maintenance

4.1 Cleaning

The meter tube and float should be cleaned as frequently as necessary to maintain the accuracy of the flowmeter. Generally the flowmeter is removed from the pipeline for cleaning, checking or repair of the meter tube or float.

4.2 Removal of the Float and Metering Tube

4.2.1 Vertical Connections (Fig. 11 , Fig. 12)

Loosen outlet fitting (2).

Follow the instructions for Horizontal Connections (4.2.2)

4.2.2 Horizontal Connections (see Fig. 10)

Loosen threaded rod (16). Remove safety retainer ring (17). Remove pressure ring (14) and pressure piece (13).

4.2.3 Horizontal and Vertical Connections

Remove and clean meter tube holder (5), meter tube (6) and float (7). Check O-Ring (15) for possible damage and replace if necessary. Reassemble flowmeter in the reverse order.

4.3 Replacement Part Orders

Please include the Instrument Serial No. when ordering replacement parts. The Serial No. may be found on the Instrument Tag (Fig. 9) which is attached to the housing cover.

5. Recommended Switch Amplifier for Alarm Signal Transmitter¹⁾

- Single channel
- Reversible operating direction
- Line interruption monitor
- Control circuit EEx ia IIC

AC 115V	WE 77/Ex-1 or KFA5-SR2-Ex 1.W	PTB No. Ex-94.C.2086
AC230V	WE 77/Ex-1 or KFA6-SR2-Ex 1.W	PTB No. Ex-94.C.2086
DC24V	WE 77/Ex-1 or KFD2-SR2-Ex 1.W	PTB No. Ex-94.C.2086

- 2-Channel (for double alarm)
- Reversible operating direction
- Line interruption monitor
- Control circuit EEx ia IIC

AC 115V	WE 77/Ex-2 or KFA5-SR2-Ex 2.W	PTB No. Ex-94.C.2086
AC230V	WE 77/Ex-2 or KFA6-SR2-Ex 2.W	PTB No. Ex-94.C.2086
DC24V	WE 77/Ex-2 or KFD2-SR2-Ex 2.W	PTB No. Ex-94.C.2086

*Buna N is required for Ammonia service, max. 120°C

¹⁾ Available as an option

6. Replaceable Parts List

6.1 10A3220 Horizontal Design 1 - 100 l/h Water

Item	Quantity	Description	Part No.	Comments
1	1	Meter housing	D609A582U01	Without valve
	1	Meter housing	D609A582U03	With valve
4	1	Meter tube holder	D376C060U01	
5	1	Meter tube holder, outlet	D376C111U01	1 & 1.6 l/h
			D376C111U02	2.5 l/h
			D376C111U03	4.0 l/h
			D376C111U04	6.0 l/h
			D376C111U05	10.0 l/h
			D376C111U06	16.0 l/h
			D376C111U07	25.0 l/h
			D376C111U08	40.0 l/h
			D376C111U09	60.0 l/h
			D376C111U010	100.0 l/h
6	1	Meter tube	D300J001U010	1.0 l/h water
			D300J001U011	1.6 l/h water
			D300J001U08	2.5 l/h water
			D300J001U09	4.0 l/h water
			D300J001U01	6.0 l/h water
			D300J001U02	10.0 l/h water
			D300J001U03	16.0 l/h water
			D300J001U04	25.0 l/h water
			D300J001U05	40.0 l/h water
			D300J001U06	60.0 l/h water
D300J001U07	100.0 l/h water			
7	1	Float	D603A134U01	For flow ranges 2.5; 6; 10; 16; 40 l/h water
	1		D603A134U02	For flow ranges 25; 60; 100 l/h water
10	1	Valve shaft	D668B003U02	Standard-Valve DM 1, 2
			D668B003U04	DVGW-Valve DM 1, 2
			D668B003U06	Standard-Valve DM 3, 2
			D668B003U07	DVGW-Valve DM 3, 2
13	1	Pressure piece	D376C057U01	
14	1	Pressure ring	D306D001U01	
15	1	O-Ring	101A902	NBR
			101V902	Viton
16	1	Threaded rod M5x6	D017H106AU20	DIN 913 SST
17	1	Safety retainer ring	D106B001U05	
18	1	O-Ring (valve)	101A701	NBR
			101V701	Viton
19	1	Valve seat	DU33E015U01	

Armored Purgemeter

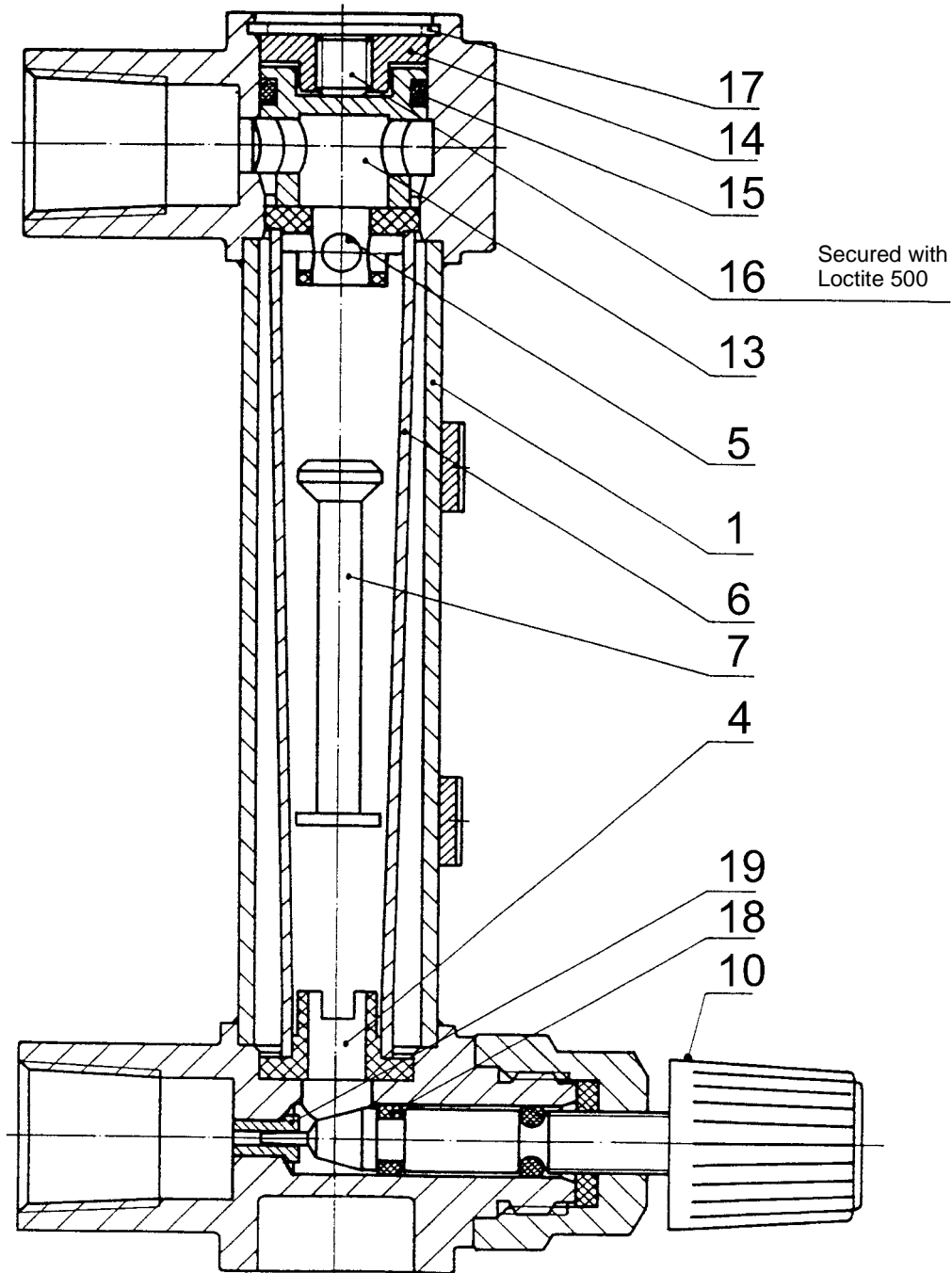

Fig. 10 Meter Tube Assembly, Complete, Horizontal Connections

6.2 10A3225 Vertical Design, 1 - 100 l/h Water

Item	Quantity	Description	Part No.	Comments
1	1	Meter housing	D609A581U01	
2	2	Fitting	D301A045U01	
4	1	Meter tube holder, inlet	D376C060U01	
5	1	Meter tube holder, outlet	D376C112U01 D376C112U02 D376C112U03 D376C112U04 D376C112U05 D376C112U06 D376C112U07 D376C112U08 D376C112U09 D376C112U010	1 & 1.6 l/h 2.5 l/h 4.0 l/h 6.0 l/h 10.0 l/h 16.0 l/h 25.0 l/h 40.0 l/h 60.0 l/h 100.0 l/h
6	1	Meter tube	D300J001U010 D300J001U011 D300J001U08 D300J001U09 D300J001U01 D300J001U02 D300J001U03 D300J001U04 D300J001U05 D300J001U06 D300J001U07	1.2 l/h water 1.6 l/h water 2.5 l/h water 4.0 l/h water 6.0 l/h water 10.0 l/h water 16.0 l/h water 25.0 l/h water 40.0 l/h water 60.0 l/h water 100.0 l/h water
7	1	Float	D603A134U01 D603A134U02	2.5-40 l/h water 25; 60; 100 l/h
8	2	O-Ring	101A902 101V902	NBR Viton

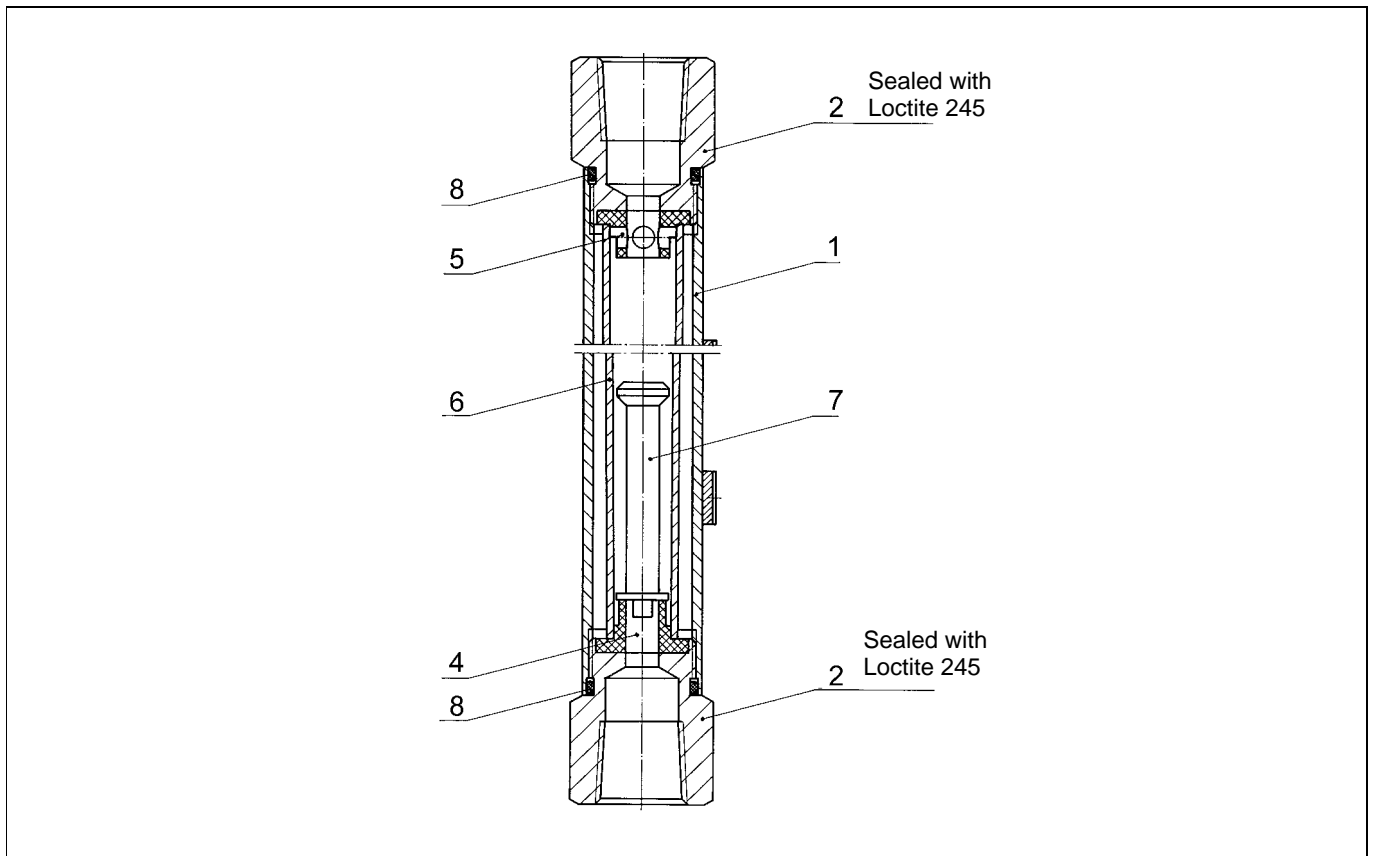

Fig. 11 Meter Tube Assembly, Complete, Vertical Connections

Armored Purgemeter

10A3225 100-3000 l/h Water

Item	Quantity	Description	Part No.	Comments
1	1	Meter housing	D609A675U01 D609A864U01	100-800 l/h 800-3000 l/h
2	2	Fitting 3/8" NPT Fitting 1/2" NPT Fitting 1" NPT Fitting 1" G	D301A086U02 D301A134U02 D301A196U02 D301A196U02	SST 316 Ti SST 316 Ti SST 316 Ti SST 316 Ti
2	2	Fitting 3/8" NPT Fitting 1/2" NPT Fitting 1" NPT Fitting 1" G	D301A121U02 D301A137U02 D301A200U02 D301A201U02	With twisted guide With twisted guide With twisted guide With twisted guide
3	1	Orifice	D356A030U01 D356A033U01 D356A042U01	100-300 l/h 400-800 l/h 800-3000 l/h
4	2	Safety retainer ring	D376H005U01 D376H007U01	800-3000 l/h
5	1	Float		
8	2	O-Ring NBR O-Ring Viton O-Ring NBR O-Ring Viton	101A902 101V902 101A928 101A928	100-800 l/h 100-800 l/h 800-3000 l/h 800-3000 l/h

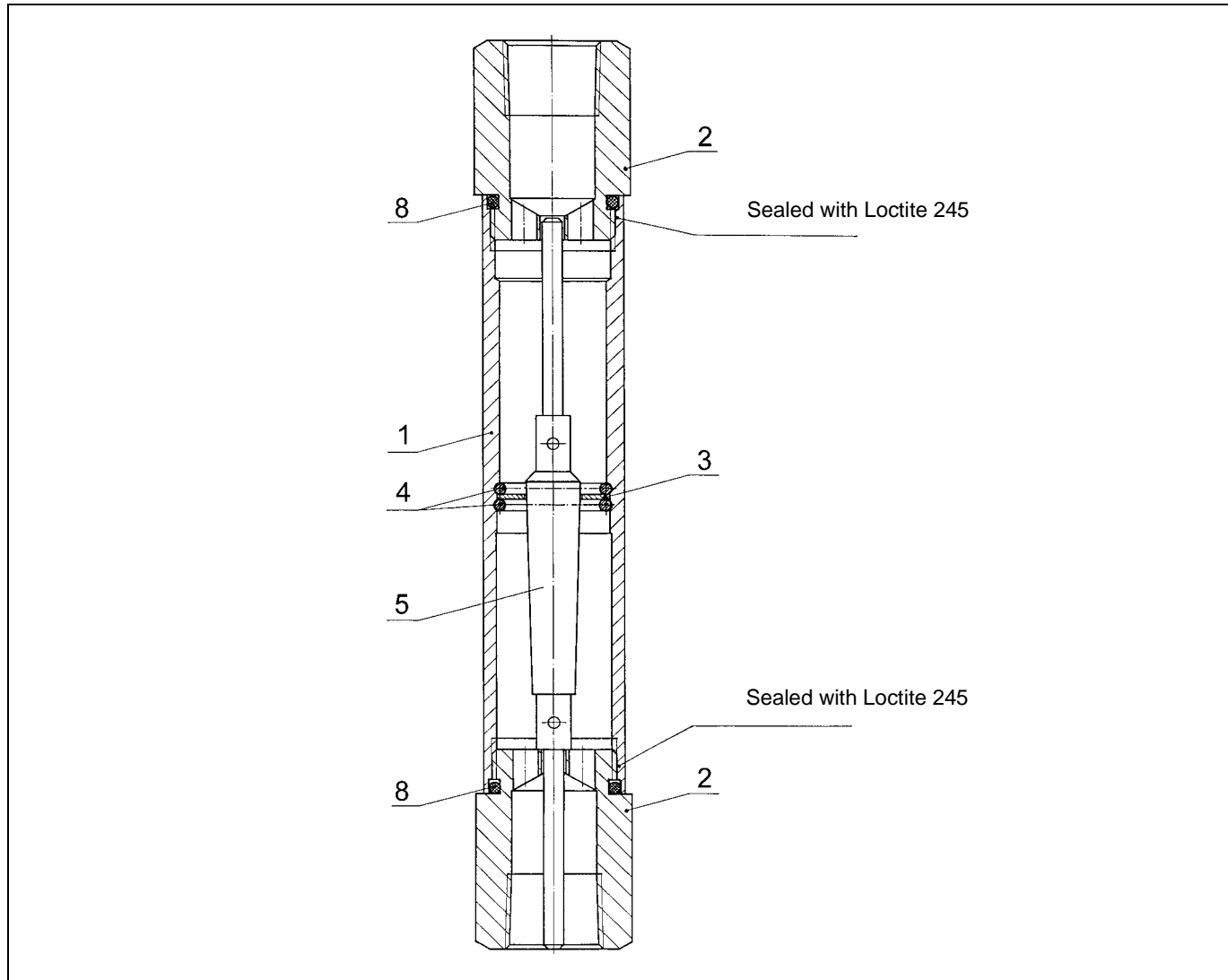

Fig. 12 Meter Tube Assembly, Complete Vertical Connections

6.3 Indicator with/without Alarm

Item	Quantity	Description	Part No.	Comments
1	1	Base plate	D355A021U01	
2	1 (2)	Adapter (double alarm)	D365B012U01	
3	1 (2)	Sleeve (double alarm)	D368H010U01	
4	1	Cover	D379D057U01	Material: Polycarbonate Material: Trogamid Material: Frame = Stainless steel with safety glass window See Specification Sheet
	1	Cover	D379D057U02	
	1	Cover complete	D613A017U01	
5	1	Gasket	D333E004U01	
6	1	Scale	-	
7	1	Tag plate	D336A008U01	For Polycarbonate- or Trogamid cover For stainless steel frame
8	1	Text tag	D338C230U01	
	1	Text tag	D338C334U01	
9	1	Window	D374A133U01	
11	1	Pointer	D410C005U01	
12	1	Slot initiator with bracket for Min. alarm	D699A020U01	
13	1	Slot initiator with bracket for Max. alarm	D699A020U02	
14	1	Bearing sleeve	D368H012U01	
15	1	Cap	D378C008U01	
16	1	Shaft	D370A009U01	
17	1	Magnet holder	D619A011U01	
18	1 (2)	Signal cable (double alarm)	D677A115U01	
19	2	Stop bracket	D353F047U01	
22	1 (2)	PG-Connector (double alarm)	1D150A1013	
23	2	Radial bearing	D103C001U01	
24	2 (4)	Parallel connector (double alarm)	D170B004U01	
25	2	Safety retainer ring	D106B001U06	
26	2	Safety washer	D106A001U11	
27	1	Serrated washer	D106D001U01	
30	2	Threaded rod	D017K106GU20	
31	1	Threaded rod	D017F106AU20	
32	1	Threaded rod	D017F109AU20	
33	2	Phillister hd., Phillips screws	D004F106AU20	M3 x 6 DIN 7985
34	4	Phillister hd., Phillips screws	D004F112AU20	M3 x 16 DIN 7985
38	4	Phillister hd., Phillips screws	D004F105AU20	M34 x 5 DIN 7985
39	4	Spring washer	D085D016AU20	
50		Meter housing		

Armored Purgemeter

Indicator with/without Alarm

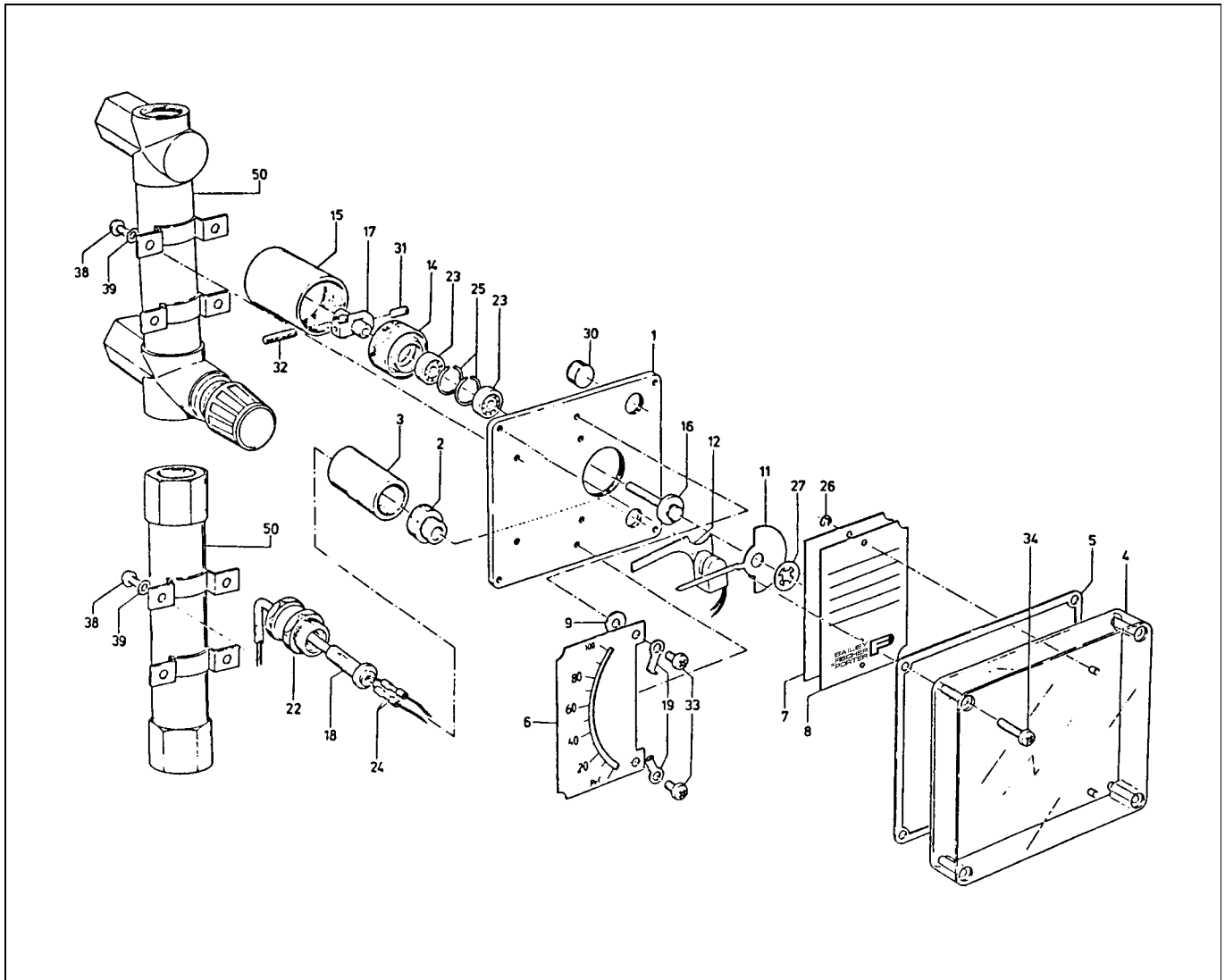

Fig. 13 Indicator with/without Alarm

6.4 Indicator with Angular Rotation Transmitter

Item	Quantity	Description	Part No.	Comments
1	1	Base plate	D355A067U01	Material: AlMg3
4	1	Cover, complete	D613A017U02	Frame. Stainless steel w/ safety glass window
5	1	Gasket	D333E004U01	
6	1	Scale	–	See Specification Sheet
7	1	Assembly ring	D376B043U01	
8	1	Text tag	D338C334U01	
11	1	Pointer	D410C005U01	
12	1	Converter	D699A031U01	Mfg'r. Tempres OPF/Ex4-2BP
14	1	Intermediate ring	D365B021U01	
15	1 1	Cap Cap	D378C008U01 D378C008U02	Material: AL Material: SS 303
17	1	Magnet holder, complete	D619A011U01	
18	2	Spacer bolts	D395A003U01	
19	2	Stop bracket	D353F047U01	
20	1	Signal cable	D431C048U01	LIFYV 2 x 0,14
22	1	Cable connector	D150A004U10	PG-7, 2-5 KU-blue
27	1	Grip ring	D106A001U12	G5 x 0.8
28	1	Belleville washer	D106D001U05	10 x 5.2 x 0.25
29	2	Flat washer	D085E017BU30	B3.2 DIN 9021
31	1	Threaded rod	D017F106AU20	M3 x 6 DIN 913
32	1	Threaded rod	D017F109AU20	M3 x 12 DIN 913
33	6	Phillister hd., Phillips screws	D004F106AU20	M3 x 6 DIN 7985
34	4	Phillister hd., Phillips screws	D004F113AU20	M3 x 18 DIN 7985
38	4	Phillister hd., Phillips screws	D004F105AU20	M3 x 5 DIN 7985
39	4	Spring washer	D085d016AU20	
50	–	Meter housing	–	

Armored Purgemeter





ABB Automation Products GmbH

Dransfelder Str. 2, D-37079 Goettingen

Tel.: +49 (0) 5 51 9 05 - 0

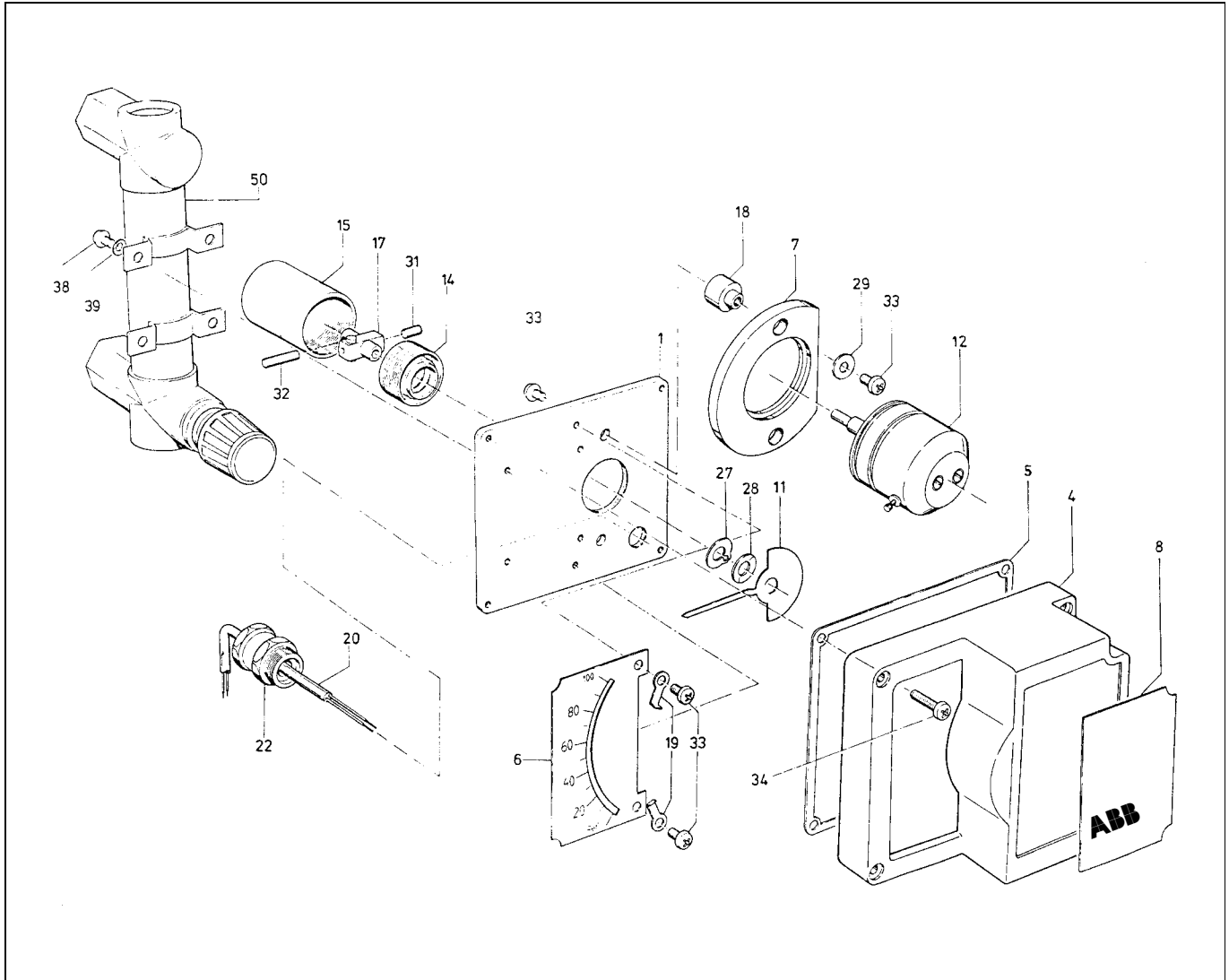
Fax: +49 (0) 5 51 9 05 - 777

<http://www.abb.com/automation>