

TriMod BESTA level switch types: A 01 04 and A 01 041
Side mounted switches for high or low alarm duties

Nominal pressure	PN 25 max. 25 bar to 300°C max. 24 bar at 330°C
Operating temperature	0 to 330°C
Ambient temperature	0 to 70°C
Density of liquid	min. 0.70 kg/dm ³
Operating differential	fixed 12 mm
Rod extensions	only with type A 01 04
Wetside material	stainless steel (316 equiv.)
Flange material	stainless steel (316 equiv.)
Switch housing material	sea water resistant die cast aluminium
Flange dimensions	92 x 92 mm P.C.D. 92 mm
Counterflange	see overleaf
Switch element	microswitch change-over (SPDT) with silver contacts
Switch rating	5A/250 VAC 5A/30 VDC
Cable gland	PG16
Enclosure	IP65
Weight	approx. 1.8 kg
Approvals	ABS, BV, DNV, GL, LRS, PRS, RINA, MRS

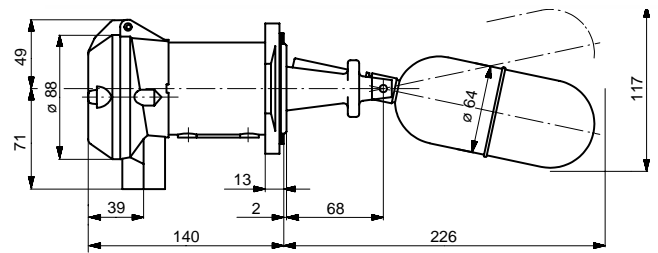

Flange dimension

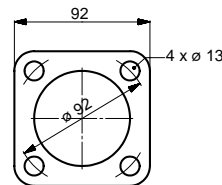

Connection diagram

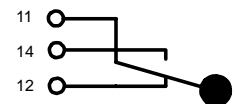

Rod extensions for type A 01 04

Depending on the tank design the level switch type A 01 04 can be equipped with rod extension Type G1 or G2 for side mounted switches.

For top mounting type G3 is used.

Since rod extensions add-on weight to the float, the minimum value for the density will change according to the following tables:

Type: G1	Type: G2	Type: G3
A max.: 1000	A + B max.: 1000 A/B: ≤ 4 A min.: 100 B min.: 100	A + B max.: 1000 A/B: ≤ 4 A min.: 50 B min.: 50

Minimum density for the float module 04G1

Rod length A (mm)	100	200	300	400	500	600	700	800	900	1000
Min. density (kg/dm ³)	0.66	0.66	0.67	0.69	0.71	0.74	0.76	0.79	0.81	0.84

Minimum density for the float module 04G2

in kg/dm³

A (mm) \ B (mm)	100	200	300	400	500	600	700	800
100	0.69	0.68	0.70	0.71	0.72	0.74	0.75	--
200	0.67	0.67	0.68	0.69	0.70	0.71	0.72	0.73
300	0.68	0.69	0.69	0.70	0.71	0.71	0.72	
400	0.70	0.70	0.71	0.71	0.72	0.73		
500	0.72	0.73	0.73	0.73	0.74			
600	0.74	0.75	0.75	0.75				
700	0.77	0.77	0.77					
800	0.79	0.80						
900	0.82							

Minimum density for the float module 04G3

in kg/dm³

A (mm) \ B (mm)	50 to 500	600	700	800
50	0.71	--	--	--
100	0.69	--	--	--
200	0.68	0.68	0.68	0.68
300	0.69	0.69	0.69	
400	0.71	0.71		
500	0.73			
600	0.75			
700	0.77			
800	0.80			
900	0.82			
950	0.83			

Options

- Dual SPDT microswitches
- Microswitches with gold plated contacts
- Self checking proximity switches acc. to NAMUR
- Enclosure IP67, or IP68 for submersible applications
- 5A/380 VAC 0,3A/440 VDC (Type AE26)
- Flameproof switches, BASEEFA-, PTB-, SAA- and SEV-approved
- Pneumatic switches ON/OFF or controllers with 0.2 to 1 bar proportional output
- High and low temperature versions
- Cable gland M24 x 1,5
- Cable entry with 3/4" NPT internal thread

- Switch housing:
 - chromated
 - stainless steel (316 equiv.)
 - epoxy painted
- Flange modules:
 - acc. to DIN PN 16 to PN 315
 - acc. to ANSI cl. 150 to cl. 2500
 - acc. to BS10 table E to T
 - acc. to JIS PN 5 to PN 63
- Float modules:
 - top mounting
 - interface control
 - with protective bellows
 - min. density 0.35 kg/dm³
- Versions acc. to NACE and in Hastelloy C or MONEL

Counterflanges

The simplest method of installing the TriMod BESTA level switches with the square flange (standard range) is to use the BESTA standard weld-on counterflanges.

These are available in two different nozzle and/or stud lengths in carbon steel (C22.8) or in stainless steel 1.4401 (316 equiv.).

Type	Specification	Flange material	Stud material
2829.1	Counterflange	C22.8	5.8
2831.3	Counterflange	1.4401	A2
2829.1V80	Extended Counterflange V = 80 mm	C22.8	5.8
2831.3V80	Extended Counterflange V = 80 mm	1.4401	A2

Temperature range: Material C22.8: -10° C to +400° C
Material 1.4401: -196° C to +400° C

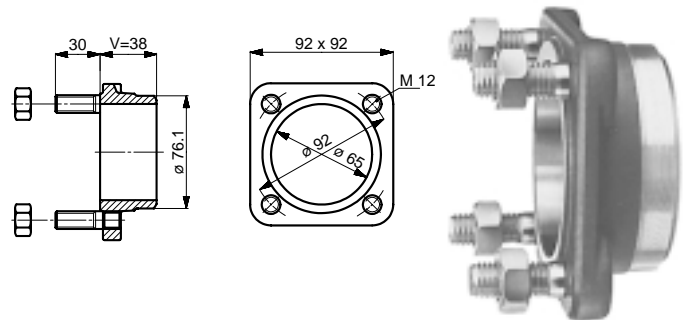

Test actuator

The test actuator allows a periodic, on-line manual function check of the level switch.

Type	Specification	Material	Temperature
2383.2	Test actuator L with intermediary	CrNi C22.8	0 to +150°C
2383.3	Test actuator L with intermediary	CrNi CrNiMo	0 to +150°C

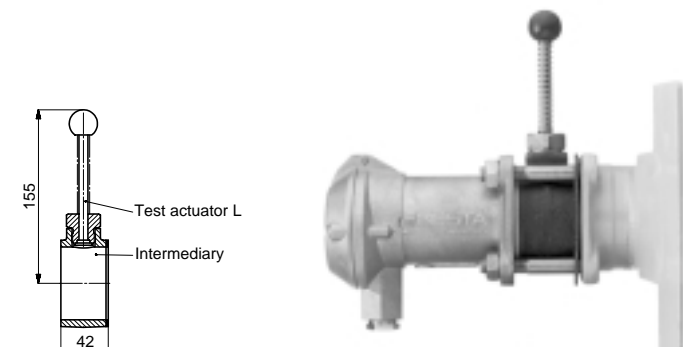

Float chambers

Wherever it is not possible or desirable to install float switches directly to the vessel, horizontal TriMod BESTA level switches can be mounted externally in a float chamber. This type of installation allows functional checks and servicing to be carried out without interrupting operation, provided that isolation and drain valves are included in the process connections.

Materials: carbon steel, high and low temp. carbon steel, stainless steel.

Manufacturing approvals: Swiss-SVTI and German-TÜV
Procedure Qualification Record: SVTI 505, AD-HP 2/1, ASME Code Sec. IX.

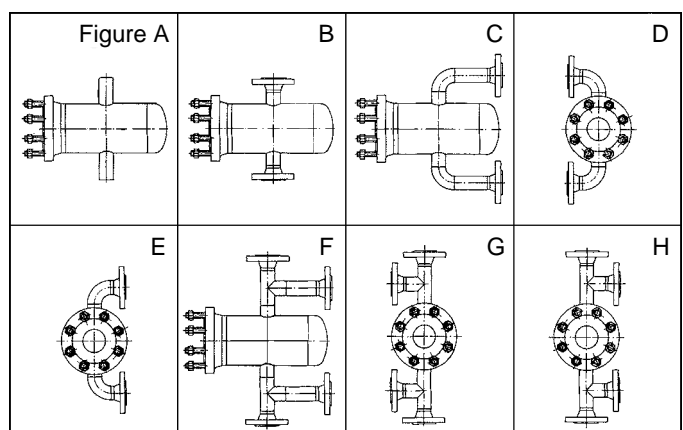

Certificates

- Material certificates acc. to EN 10204-2.2 and EN 10204-3.1B
- Test record: hydraulic pressure test and functional tests
- Test records of material tests: x-ray, ultra sonic, charpy, hardness etc.

Quality Assurance

- BESTA AG is certified according to ISO 9001.

With reservation of technical modifications

LTDS01E/07.97

Ackerstrasse 45, CH-8610 Uster/Switzerland
Phone +41-1-941 30 20, Fax +41-1-941 40 15
E-Mail: info@besta.ch <http://www.besta.ch>

BESTA LTD

TriMod BESTA level switches with adjustable operating differential for pump control

Types: A 01 090, A 01 091, A 01 092, A 01 093, A 01 095



Nominal pressure	PN 25 max. 25 bar to 300 °C max. 24 bar at 330 °C
Operating temperature	0 to 330 °C
Ambient temperature	0 to 70 °C
Density of liquid	min. 0.8 kg/dm ³ (A 01 095 min. 0.90 kg/dm ³)
Operating differential S	see table below
Wetside material	stainless steel (316 equiv.)
Flange material	stainless steel (316 equiv.)
Switch housing material	sea water resistant die cast aluminium
Flange dimensions	92 x 92 mm P.C.D. 92 mm
Counter flanges	see overleaf
Switch element	microswitch changeover (SPDT) with silver contacts
Switch rating	5A/250 VAC 5A/30 VDC
Cable gland	PG16
Enclosure	IP65
Weight	approx. 2.0 kg
Approvals	ABS, BV, DNV, GL, LRS, PRS, RINA, MRS

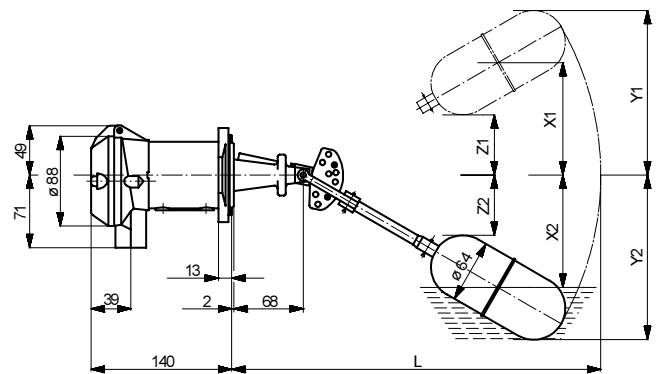
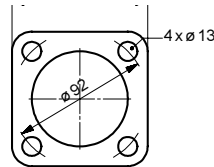

Adjustment of switching differential

The switching differential can be set by inserting pegs in holes 1 to 9 of the adjustment block (see sketch). The resulting differentials, the position of the switching points and the overall swept arc of the float can be seen in the table below. The values are in mm and are referenced to water at 20°C and density of 1.0 kg/dm³.

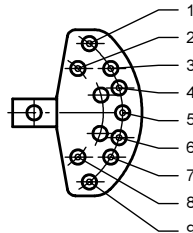

Connection diagram

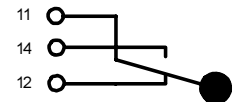

Type	A 01 090					A 01 091					A 01 092					A 01 093					A 01 095				
L	278 mm					361 mm					461 mm					561 mm					246 mm				
Pos.	X1	X2	Diff. S	Y1 (Z2)	Y2 (Z1)	X1	X2	Diff. S	Y1 (Z2)	Y2 (Z1)	X1	X2	Diff. S	Y1 (Z2)	Y2 (Z1)	X1	X2	Diff. S	Y1 (Z2)	Y2 (Z1)	X1	X2	Diff. S	Y1 (Z2)	Y2 (Z1)
1-4	+108	+60	48	175	(10)	+157	+85	72	238	(20)	+230	+125	105	315	(50)	+292	+160	132	395	(75)	+100	+55	45	147	(10)
1-5	+108	+15	93	175	35	+157	+25	132	238	37	+230	+39	191	315	39	+292	+48	244	395	42	+100	+18	82	147	35
1-6	+108	-25	133	175	85	+157	-37	194	238	105	+230	-51	281	315	135	+292	-65	357	395	165	+100	-18	118	147	74
1-7	+108	-52	160	175	125	+157	-90	247	238	165	+230	-124	354	315	215	+292	-160	452	395	265	+100	-46	146	147	115
1-8	+108	-80	188	175	153	+157	-128	285	238	206	+230	-171	401	315	275	+292	-215	507	395	345	+100	-70	170	147	128
1-9	+108	-110	218	175	175	+157	-160	317	238	238	+230	-212	442	315	315	+292	-265	557	395	395	+100	-90	190	147	147
2-5	+98	+15	83	153	35	+122	+25	97	206	37	+181	+39	142	275	39	+230	+48	182	345	42	+79	+18	61	128	35
2-6	+98	-25	123	153	85	+122	-37	159	206	105	+181	-51	232	275	135	+230	-65	295	345	165	+79	-18	97	128	74
2-7	+98	-52	150	153	125	+122	-90	212	206	165	+181	-124	305	275	215	+230	-160	390	345	265	+79	-46	125	128	115
2-8	+98	-80	178	153	153	+122	-128	250	206	206	+181	-171	352	275	275	+230	-215	445	345	345	+79	-70	149	128	128
2-9	+98	-110	208	153	175	+122	-160	282	206	238	+181	-212	393	275	315	+230	-265	495	345	395	+79	-90	169	128	147
3-5	+58	+15	43	125	35	+81	+25	56	165	37	+122	+39	83	215	39	+145	+48	97	265	42	+52	+18	34	115	35
3-6	+58	-25	83	125	85	+81	-37	118	165	105	+122	-51	173	215	135	+145	-65	210	265	165	+52	-18	70	115	74
3-7	+58	-52	110	125	125	+81	-90	171	165	165	+122	-124	246	215	215	+145	-160	305	265	265	+52	-46	98	115	115
3-8	+58	-80	138	125	153	+81	-128	209	165	206	+122	-171	293	215	275	+145	-215	360	265	345	+52	-70	122	115	128
3-9	+58	-110	168	125	175	+81	-160	241	165	238	+122	-212	334	215	315	+145	-265	410	265	395	+52	-90	142	115	147
4-6	+25	-25	50	85	85	+31	-37	68	105	105	+48	-51	99	135	135	+63	-65	128	165	165	+23	-18	41	74	74
4-7	+25	-52	77	85	125	+31	-90	121	105	165	+48	-124	172	135	215	+63	-160	223	165	265	+23	-46	69	74	115
4-8	+25	-80	105	85	153	+31	-128	159	105	206	+48	-171	219	135	275	+63	-215	278	165	345	+23	-70	93	74	128
4-9	+25	-110	135	85	175	+31	-160	191	105	238	+48	-212	260	135	315	+63	-265	328	165	395	+23	-90	113	74	147
5-7	-15	-52	37	35	125	-33	-90	57	37	165	-40	-124	84	39	215	-50	-160	110	42	265	-12	-46	34	35	115
5-8	-15	-80	65	35	153	-33	-128	95	37	206	-40	-171	131	39	275	-50	-215	165	42	345	-12	-70	58	35	128
5-9	-15	-110	95	35	175	-33	-160	127	37	238	-40	-212	172	39	315	-50	-265	215	42	395	-12	-90	78	35	147
6-9	-55	-110	55	(10)	175	-80	-160	80	(20)	238	-105	-212	107	(50)	315	-135	-265	130	(75)	395	-45	-90	45	(10)	147

Options

- Dual SPDT microswitches
- Microswitches with gold plated contacts
- Flameproof microswitches
- Self checking proximity switches acc. to NAMUR
- Enclosure IP67, or IP68 for submersible applications
- 5A/380 VAC 0,3A/440 VDC (type: AE26)
- Flameproof switches, BASEEFA-, PTB-, SAA- and SEV-approved
- Pneumatic switches ON/OFF with 3/2 way valve

- High and low temperature versions
- Cable gland M24 x 1,5
- Cable entry with 3/4" NPT internal thread
- Switch housing:
 - chromated
 - stainless steel (316 equiv.)
 - epoxy painted
- Flange modules: - acc. to ANSI, DIN, BS10 and JIS
- Float modules: - interface control

Counterflanges

The simplest method of installing TriMod BESTA level switches type A 01 090 to A 01 095 is to use the BESTA standard weld-on counter flanges.

These are available in carbon steel C22.8 (A105) and in stainless steel 1.4401 (316 equivalent).

Type	Specification	Flange material	Stud material
2829.1	Counterflange	C22.8	5.8
2831.3	Counterflange	1.4401	A2

Temperature range: material C22.8: -10 °C to +400 °C
 material 1.4401: -196 °C to +400 °C

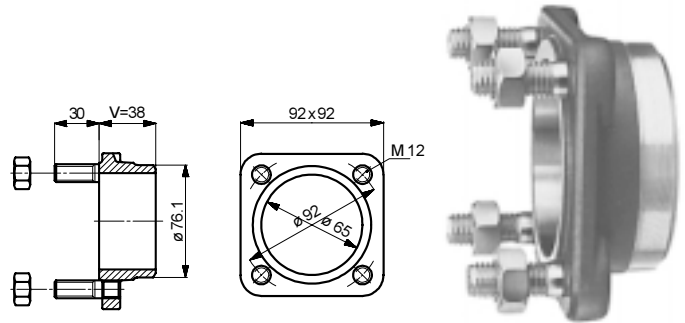

Certificates

- Material certificates acc. to EN10204-2.2 and EN10204-3.1B
- Test records of hydraulic pressure tests and functional tests
- Test records of material tests: x-ray, ultra sonic, charpy, hardness etc.

Quality Assurance

- BESTA AG is certified according to ISO 9001.

TriMod BESTA level switches type: A 01 140
A 01 141

Top mounted level switches for level alarm or pump control applications

Nominal pressure	PN 16 max. 16 bar to 300°C max. 10 bar at 330°C
Operating temperature	0 to 330°C
Ambient temperature	0 to 70°C
Density of liquid	
- pump control	min. 0.45 kg/dm ³
- alarm	min. 0.30 kg/dm ³
Operating differential S	A 01 140: 12 to 1340 mm A 01 141: 12 to 2840 mm
Wetside material	stainless steel (316 equiv.)
Switch housing material	sea water resistant die cast aluminium
Flange dimensions	92 x 92 mm (P.C.D. 92 mm)
Counter flange	see overleaf
Switch element	microswitch changeover (SPDT) with silver contacts
Switch rating	5A/250 VAC 5A/30 VDC
Cable gland	PG16
Enclosure	IP65
Weight	A 01 140: approx. 2.5 kg A 01 141: approx. 2.7 kg
Approvals	ABS, BV, DNV, GL, LRS, PRS, RINA, MRS

Connection diagram

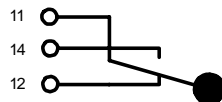

Setting the switching differential

1. For pump control (2 switch points)

The required differential is set by fixing the two stop collars in the appropriate positions on the rod. The counterweight has to be adjusted to compensate for the rod weight (without float), until the cross arm is balanced. The float slides up and down the rod with the liquid level and actuates the switch at the set position of the stop collars.

The switch remains latched between the two positions, which are for applications such as pump control where the contactor coil would need to remain energized throughout the pumping cycle.

2. For alarm operation (1 switch point)

Only the lower collar is fixed on the rod (below the float). Within the limit of the rod length, the height of the alarm point can be chosen as required. The counterweight has to be set, to outweigh the rod (without float). The alarm switching differential is 12 mm.

Adjustment at factory

The level switches are factory set for pump control. Distance X = 38 mm. If the rods have to be shortened or the switch has to be used for alarm purposes, the position of the counterweight has to be adjusted, as described on the back page.

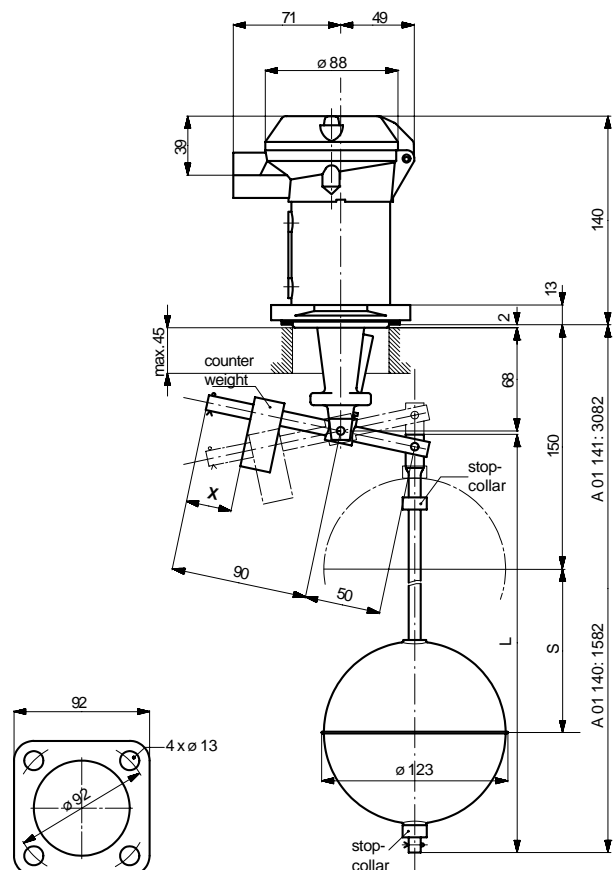

Distance X for counterweight (see drawing on the front page)

Switch types

...140/...145

rod length L in (mm)	pump control X in (mm)	alarm X in (mm)	
		...140	...145
500	63	45	4
600	60	42	4
700	57	39	4
800	54	36	4
900	51	32	4
1000	47	30	4
1100	44	26	4
1200	41	23	4
1300	38	20	4
1400	35	17	4
1500	32	14	4

Switch types

...141/...146

rod length L in (mm)	pump control X in (mm)	alarm X in (mm)	
		...141	...146
1500	54	45	4
1600	53	43	4
1700	51	41	4
1800	49	40	4
1900	48	38	4
2000	46	36	4
2100	44	35	4
2200	43	33	4
2300	41	31	4
2400	39	30	4
2500	38	28	4
2600	36	27	4
2700	34	25	4
2800	33	23	4
2900	31	22	4
3000	29	20	4

Installation

Over open tanks or sumps on a bracket. On closed tanks on the manhole cover with the float mounted from the inside. In the absence of a manhole, i.e. the float can not be mounted from the inside, an intermediate flange with an inside diameter of min. 125 mm of flange modules acc. to DIN DN125 or ANSI DN5" should be used. If turbulence occurs, the rod should be guided loosely at the lower end.

Counterflanges

The simplest method of installing the TriMod BESTA level switch types A 01 140 and A 01 141 is to use the BESTA standard welded-on counterflanges.

These are available in carbon steel C22.8 (A105 equiv.) and in stainless steel 1.4401 (SS316 equiv.).

If the float can be mounted from the inside, the counterflange can be welded directly to the tank. Otherwise the counterflange has to be welded to an intermediate flange (I.D. min. 125 mm).

Type	Specification	Flange material	Stud material
2829.1	Counterflange	C22.8	5.8
2831.3	Counterflange	1.4401	A2

Options

- Dual SPDT microswitches
- Microswitches with gold plated contacts
- Self checking proximity switches acc. to NAMUR
- Enclosure IP67, or IP68 for submersible applications
- 5A/380 VAC 0.3A/440 VDC (type: AE26)
- Explosion proof switches, BASEEFA-, PTB-, SAA- and SEV-approved
- Pneumatic switches ON/OFF

Certificates

- Material certificates acc. to EN 10204-2.2 and EN 10204-3.1B
- Test records of hydraulic pressure tests and functional tests
- Test records of material tests: x-ray, ultra sonic, charpy, hardness etc.

Temperature range: Material C22.8 -10 to +400°C
Material 1.4401: -196 to +400°C

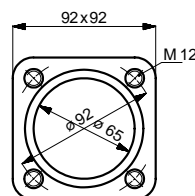
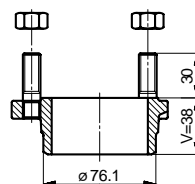

- High and low temperature versions
- Cable gland M 24 x 1.5
- Cable entry with 3/4" NPT internal thread
- Switch housing: - chromated
- stainless steel (316 equiv.)
- epoxy painted
- Flange modules: - acc. to ANSI, DIN, BS and JIS
- Float modules: - interface control

Quality Assurance

- BESTA AG is certified according to ISO 9001.